

# Radial Head

Replacement System

**Surgical Technique**

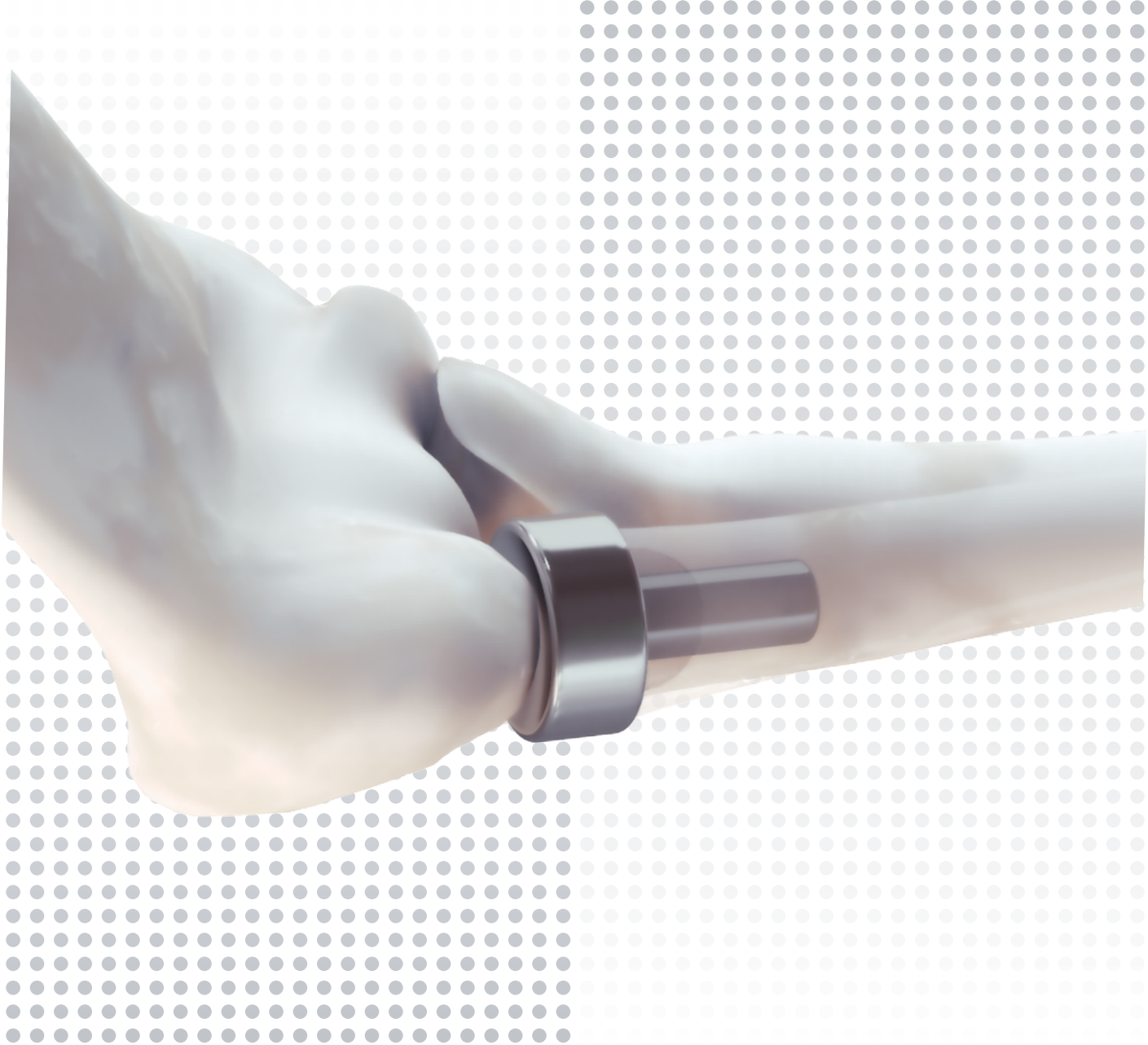

# The Radial Head

Replacement System

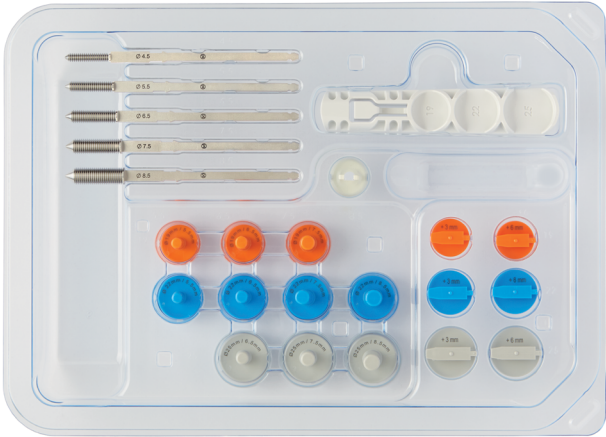

See Better,  
Size Better

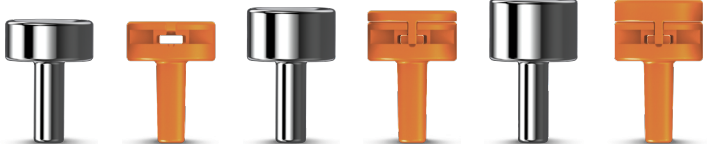

# Table of Contents

---

## Introduction

---

Radial Head Replacement System	2
Indications	4
Operative Planning	5

## Surgical Technique

---

Surgical Technique	8
Optional Removal of Planer from Sounder	13
Implant Removal	21
Potential Adverse Events	22

## Product Information





---

Implants	23
Instrument Kit	24
Sets	24
Carrying Case	25
Additional Sets Available	25

### MR

Refer to the corresponding labeling for additional instructions or information essential to safe use in the MR environment.

---

	Addendum A
	Image Intensifier Control
	Notes
	Warnings

# Radial Head Replacement System

---

The DePuy Synthes Radial Head Replacement System is a solution for replacing the radial head in patients. The treatment goals for radial head fractures are to restore elbow stability and forearm rotation, to preserve elbow motion, and to maintain the length of the radius. The DePuy Synthes Radial Head Replacement System is used to treat patients who have experienced destabilizing radial head fractures that cannot be repaired. The Radial Head Replacement is also useful in the elective management of elbow arthritis in the radio-capitellar joint. Our solution is designed to support against longitudinal collapse of the radius allowing associated soft tissue injuries to heal with the radial head in an anatomic position.<sup>3</sup>

There are two main implant philosophies for radial head replacements. Rigid fixation with a straight or anatomically curved stem that can be press-fit or cemented, and loose fitting with a straight smooth stem. Traditionally, press-fit or cemented stem implants rely on their position and their approximation of the native anatomy to achieve physiological tracking with the capitellum and the lesser sigmoid notch.<sup>4</sup> Smooth stemmed implants are designed to allow for unrestricted motion, allowing the stem to self-center inside the canal. The unrestricted fit accommodates patient specific incongruities among the implant, the capitellum, and the lesser sigmoid notch during elbow movement (flexion, extension, and prono-supination).<sup>5,6</sup> At this time, literature and clinical experience suggests straight smooth stemmed implants are associated with lower incidence of symptomatic implant loosening than press-fit implants.<sup>7-16</sup>

The DePuy Synthes Radial Head Replacement System offers 30 one-piece straight smooth stemmed implant options separately packaged. There are 3 head diameters, 3 head heights and 4 stem diameters. The implant offering is accompanied by a sterile single-use instrument kit to be utilized with the individually packed sterile Radial Head Replacements. The kit contains only the instruments needed to perform one radial head replacement surgery with one of the 30 DePuy Synthes Radial Head Replacements. The treating physician must compare their patient's anatomic and biomechanical requirements to the implants available when planning surgical intervention.

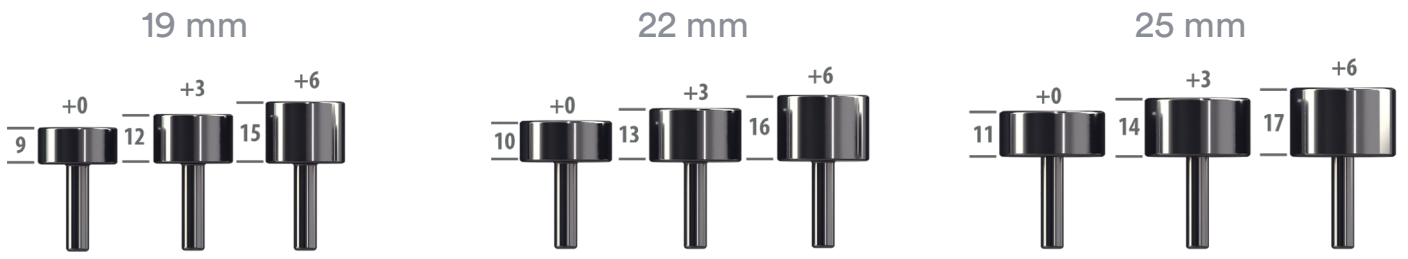

Stem Ø (mm)	5.5	6.5	7.5
Stem Length (mm)	21	22	23

Stem Ø (mm)	5.5	6.5	7.5	8.5
Stem Length (mm)	21	22	23	24

Stem Ø (mm)	6.5	7.5	8.5
Stem Length (mm)	22	23	24

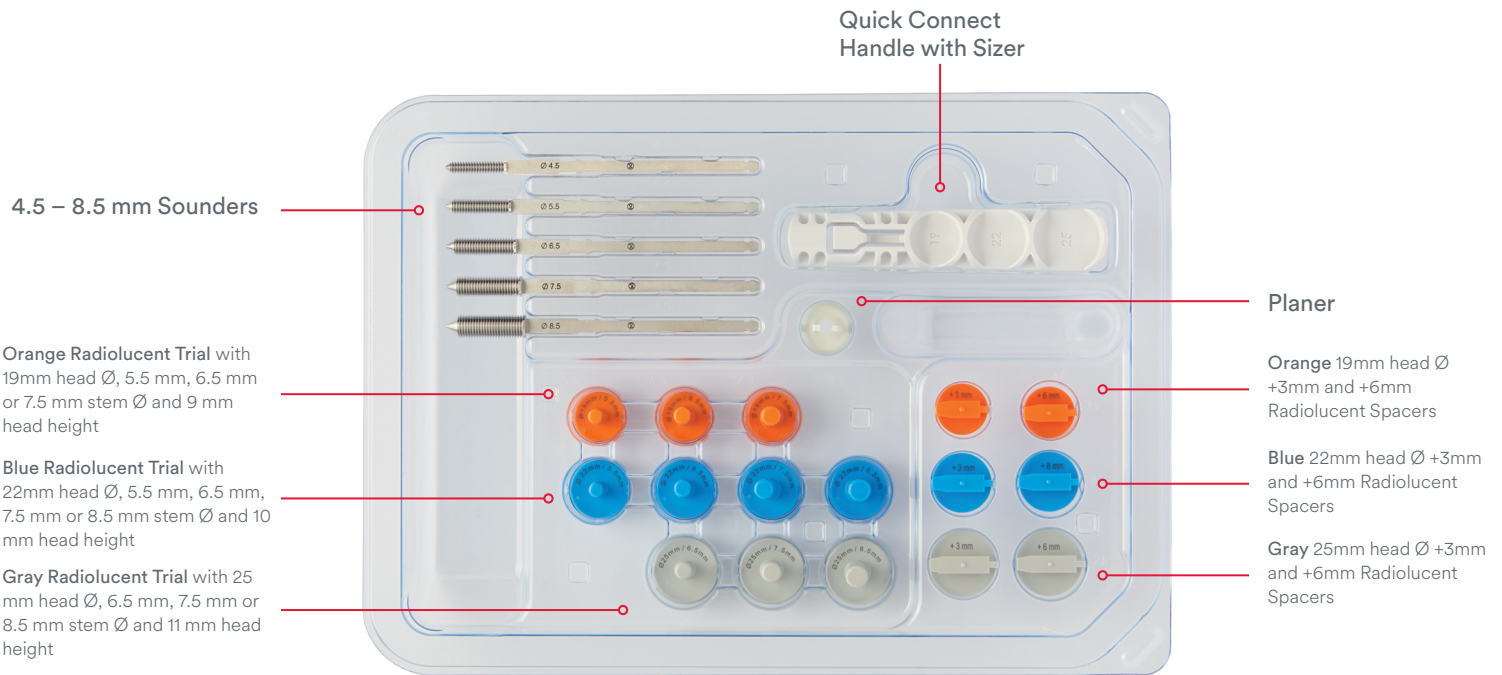

# Indications

---

- Replacement of the radial head for degenerative or post-traumatic disabilities presenting pain, crepitation, and decreased motion at the radio-humeral and/or proximal radio-ulnar joint with:
  - joint destruction and/or subluxation visible on x-ray; and/or
  - resistance to conservative treatment.
- Primary replacement after fracture of the radial head.
- Symptomatic sequelae after radial head resection.
- Revision following failed radial head arthroplasty.

## Contraindications

**Absolute contraindications include:** Infection, sepsis, and osteomyelitis.

**Relative contraindications include:** Uncooperative patient or patient with neurologic disorders who are incapable of following directions, osteoporosis, metabolic disorders which may impair bone formation, osteomalacia, distant foci of infections which may spread to the implant site, rapid joint destruction, marked bone loss or bone resorption apparent on roentgenogram.

# Operative Planning

---

## Step 1: Planning and Patient Positioning

- 1a.** Before undertaking replacement surgery, the surgeon must determine if the implant sizes offered will match their patient's anatomic and biomechanical needs.
- 1b.** During the pre-operative exam and imaging, attempt to determine the extent of ligament and additional bone injury beyond the radial head.
- 2.** Position the patient on the table in the supine position.
- 3.** Prepare the elbow using sterile technique ensuring you have access to the hand, wrist and upper arm. You will need access to imaging throughout the procedure.

**Important:** Fractures with extensive radial neck comminution may require repair of the radial neck prior to replacement of the radial head.

## Step 2: Approach

There are many surgical approaches for radial head replacement. (Figures 1A and 1B)

1. One of the more common approaches is the Kaplan approach where a longitudinal incision is made from the supracondylar ridge, over to the epicondyle distally 3-4 cm over the radial head. The common extensors are incised through Kaplan's interval. It is advisable to stay anterior to the equator of the lateral epicondyle to protect the lateral ulnar collateral ligament and pronate the forearm to protect the posterior interosseous nerve (PIN).
2. Another common approach is the Kocher approach where the incision extends along the interval between the anconeus and extensor carpi ulnaris (ECU). It is advisable to pronate the forearm to move the PIN from the field. Divide the annular ligament laterally or slightly anteriorly to mobilize the radial head. Minimize disruption to un-injured ligaments (such as the lateral ulnar collateral).

■ **Note:** During surgical approach, pay special attention to preserving the Lateral Ulnar Collateral Ligament (LUCL). If the ligament is damaged or released, repair it after the radial head is replaced to ensure that function and stability is restored.

▲ **Precautions:** Radial head subluxation can occur if the annular ligament is not repaired. To prevent subluxation or dislocation of the radial head, ensure ulnohumeral joint stability through anatomic reduction of any ulnar injury and restore global stability of the elbow using appropriate fixation tools.

Figure 1A

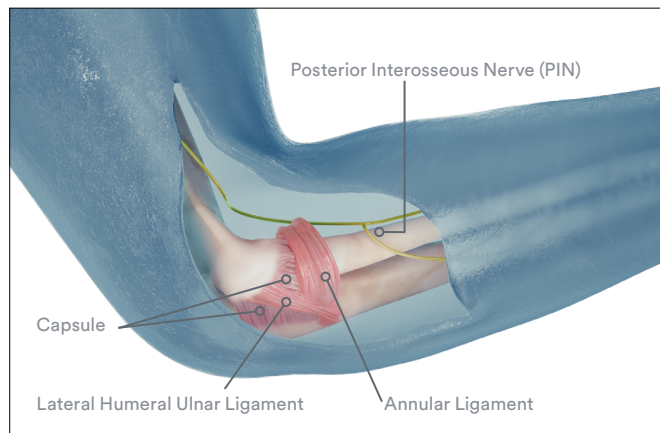
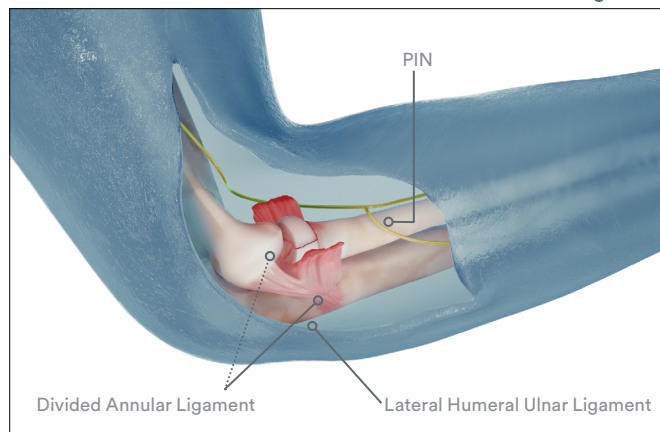

Figure 1B





---

### Step 3: Open sterile single-use instrument kit

**Product Needed:** 03.405.000S Radial Head Replacement Instrument Kit, Sterile

#### Circulating Nurse (non-sterile field):

1. Open the outer box and remove the inner tray.
2. Peel back the lid and transfer the sterile single-use inner tray onto the sterile field.

#### Scrub Nurse (sterile field):

1. Lift the open corner of the plastic lid from the tray to access the sterile single-use instruments. (Figure 2)

Figure 2



# Surgical Technique

## Step 1: Resect radial head

1. If applicable, remove the fragments of the fractured radial head to ensure no bone remains in the joint. (Figure 3)
2. Select an appropriate size micro sagittal saw blade that does not have excursion outside of the joint capsule. Retractors can be used to prevent the sawblade from injuring the soft tissue.
3. Determine resection level within available implant range that is appropriate for the patient's radial head size. The shortest implant yields a head height of 9 mm with a 19 mm head diameter and the largest implant yields a head height of 17 mm with a 25 mm head diameter. Reference Figure 4 to see the minimum and maximum head height per head diameter. (Figure 4)

Figure 3

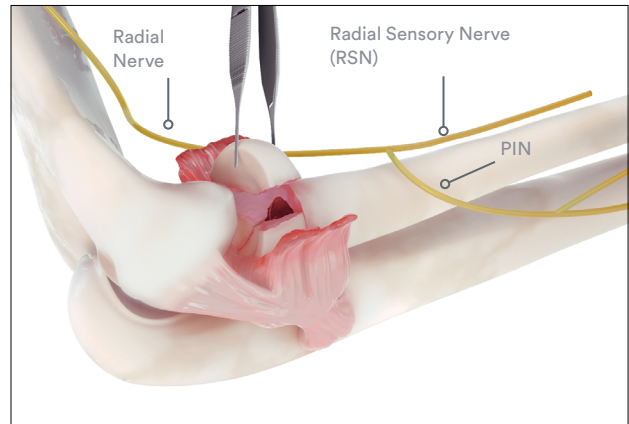
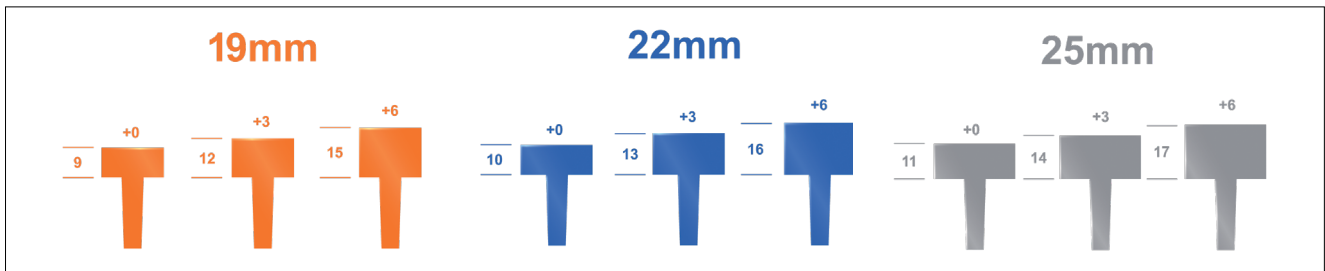

Figure 4



4. Using the micro sagittal saw, resect bone at the level of the radial head/neck junction, perpendicular to the axis of the radial neck. The cut should be just distal to the distal edge of the Proximal Radioulnar Joint (PRUJ). (Figure 5)

▲ **Precautions:** Minimize radial neck resection.

5. If possible, save the radial head and fragments, as they will be utilized to determine initial component sizing.

Figure 5

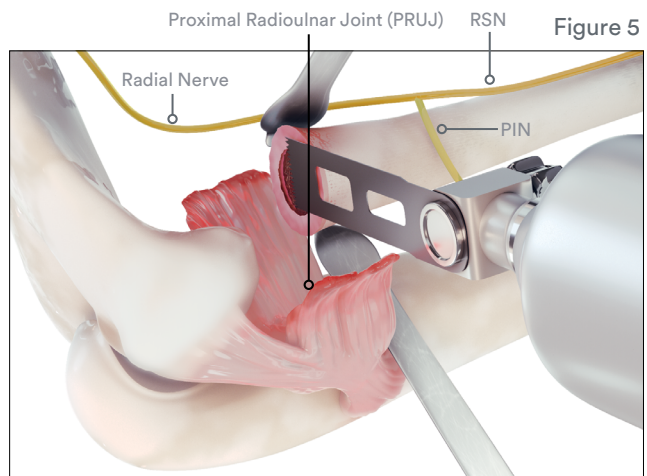

## Step 2: Determine radial head diameter and height

**Instrument Needed:** Quick Connect Handle with Sizer\*

\*Handle is part of the Radial Head Replacement Instrument Kit.

■ **Note:** The Quick Insertion Handle with Sizer provides guidance regarding the head diameter and head height in millimeters (mm).

1. Place the resected head or reassembled fragments into one of the three sizing dishes in the Quick Connect Handle with Sizer (Handle) that best matches the head. It is most important to determine the diameter of the articular surface as opposed to the maximum outer diameter of the head, if possible. (Figures 6A and 6B)

■ **Note:** The head is commonly elliptically shaped, choose the minimum diameter and not the maximum diameter.

**Important:** To reduce the risk of overstuffing, downsize the head if it is between sizes in diameter and/or height. This will better facilitate soft tissue closure, including the annular ligament, at the end of the case and ease implantation.

▲ **Precautions:** Overstuffing results from over lengthening the radius relative to the ulna and/or increasing radial head diameter relative to the native radial head. Reduced motion and/or pain may ensue, necessitating revision.

2. Evaluate the height of the head with the ruler sizing feature incorporated onto the backside of the Handle. If the head is between sizes in diameter and/or height, it is advisable to downsize to reduce the risk of overstuffing. (Figure 7).

Figure 6A



Figure 6B



Figure 7

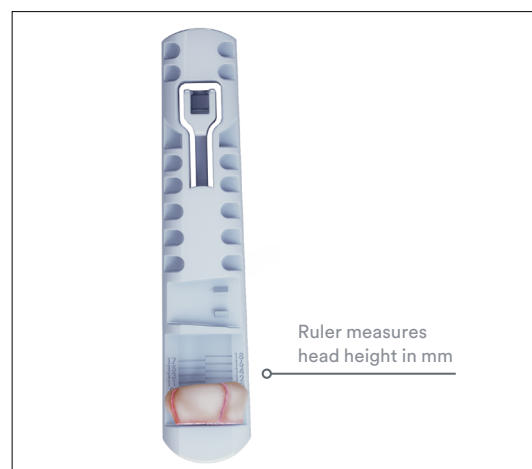

### Step 3: Assemble the Sounder

**Instrument Needed:** Handle and 4.5 mm – 8.5 mm Sounders\*

\*Sounders and Handle are part of the Radial Head Replacement Instrument Kit.

1. Align and insert the D-shaped shaft of the Sounder into the D-shaped slot of the Handle. (Figure 8)

■ **Note:** 4.5mm is the starting size for sounding the radial canal.

2. While inserting the Sounder, gently depress the open “U” shaped button that protrudes from the Handle to enable the connection on the Sounder to slide completely into the Handle slot. (Figure 9)
3. Once the Sounder is fully seated, release the button on the Handle. If the Sounder is properly captured to the Handle you will hear a click.
4. Pull on the Sounder to ensure it is properly retained. The assembly is now ready for use.

Figure 8



Figure 9

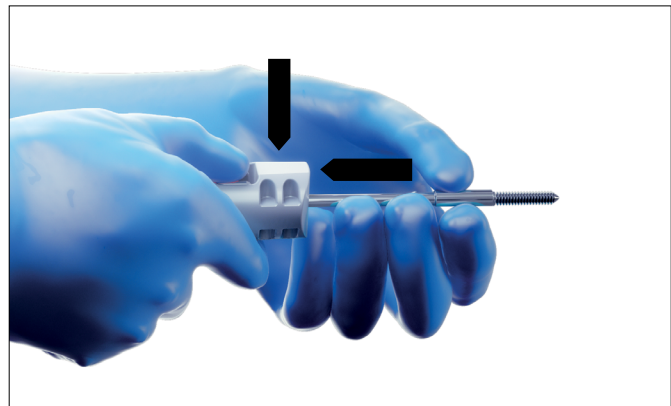

## Step 4: Sound radial canal

**Instrument Needed:** Handle and 4.5 mm – 8.5 mm Sounders\*

\*Sounders and Handle are part of the Radial Head Replacement Instrument Kit.

**Important:** The Sounders are intended to be used by hand, to probe for depth and diameter of the radial canal. The intention of the Sounder is not to ream endosteal bone.

▲ **Precautions:** Do not use impaction to advance or remove Sounder from radial canal.

1. Identify the orientation that offers the best visibility of the axis of the radius and easy access to the medullary canal. This orientation is favorable for sounding and implantation. (Figure 10)

**Important:** Depending on the anatomy, the radius may be lifted with forceps or retracted to gain access to the medullary canal.

▲ **Precautions:** Surgical access to the medullary canal must be sufficient to prevent damage to the radial neck while using the Sounder.

■ **Note:** Take care to avoid prolonged traction or pressurization of the PIN.

2. Introduce the tip of the starting 4.5 mm Sounder into the center of the canal while maintaining axial alignment.

Figure 10

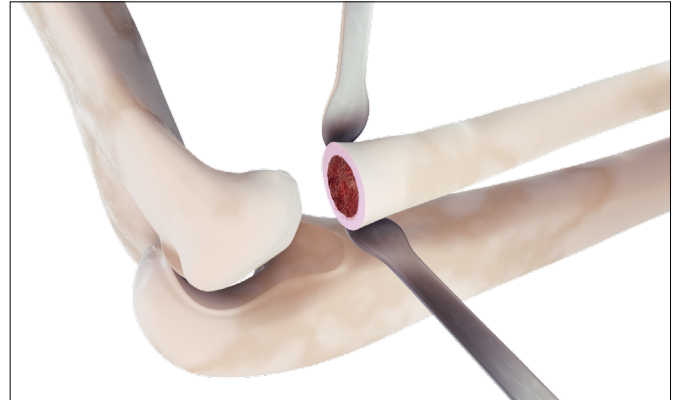

3. Advance the Sounder until the end of the ribs is level with the radial neck osteotomy. (Figure 11A and 11B)

**Important:** Do not place thumb on “U” shaped button while Sounding or the Sounder may become disengaged from the Handle.

4. Use sequentially larger diameter Sounders until resistance is met. Note the size of the final Sounder used. (Figure 11B)

**Important:** The purpose of the Sounder is not to remove endosteal bone.

■ **Notes:**

- To change the Sounder diameter, gently depress the “U” shaped button that protrudes from the Handle to release the Sounder from the Handle. (Figure 12) Take care not to grip the depth clearing ribs during disassembly. To reassemble, follow Step 3: Assemble the Sounder located on page 10.
- A fluoroscopy image can be taken of the Sounder to show the intended depth, diameter and trajectory of the stem. (Figure 13)

Figure 11A

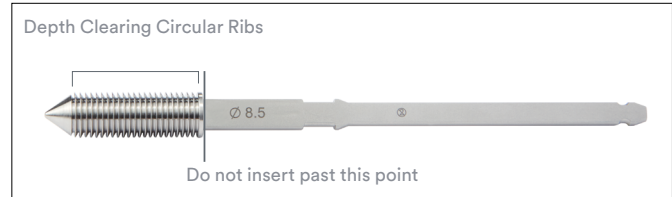

Figure 11B



Figure 12

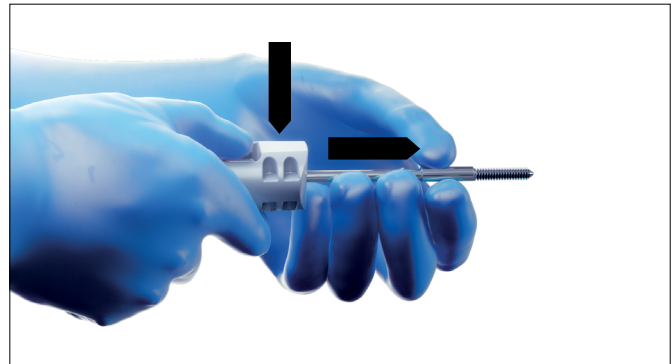

Figure 13



## Step 5: Optional assembly of Planer

**Instrument Needed:** Sounder, Planer and Handle\*  
 \*Sounders, Planer and Handle are part of the Radial Head Replacement Instrument Kit.

1. Disassemble the Sounder from the Handle by gently depressing the “U” shaped button that protrudes from the Handle to release the Sounder from the Handle. (Figure 14)

■ **Note:** Take care not to grip the depth clearing ribs during disassembly.

2. Align the D-shaped slot on the Planer with the D-shaped shaft of the Sounder (Figure 15A) and slide the Planer down the shaft, towards the ribs, until you hear the tabs click into place. (Figures 15B and 15C)

■ **Notes:**

- The Planer has been designed to be universal and will fit onto all Sounders. You should use the Planer with the final Sounder used.
- As compared to Figure 15C where the Planer tabs have audibly clicked into place and can be seen in place, Figure 15D represents the condition of incompletely engaged Planer tabs.

3. Follow Step 3: Assemble the Sounder located on page 10.

Figure 14

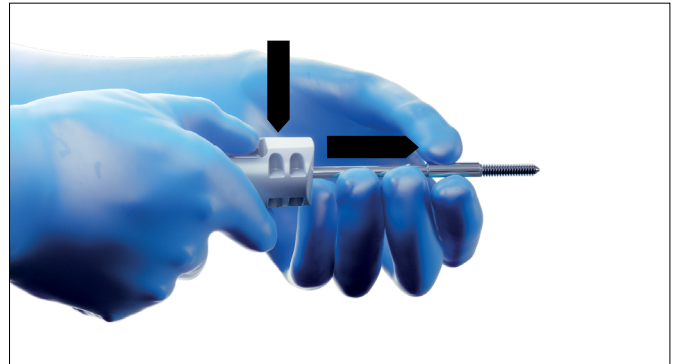

Figure 15A

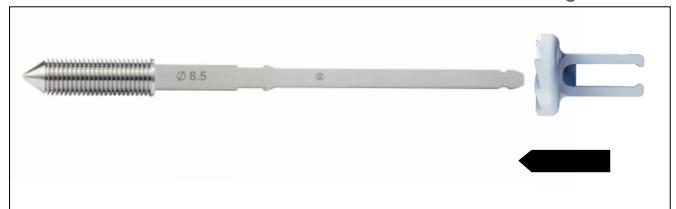

Figure 15B

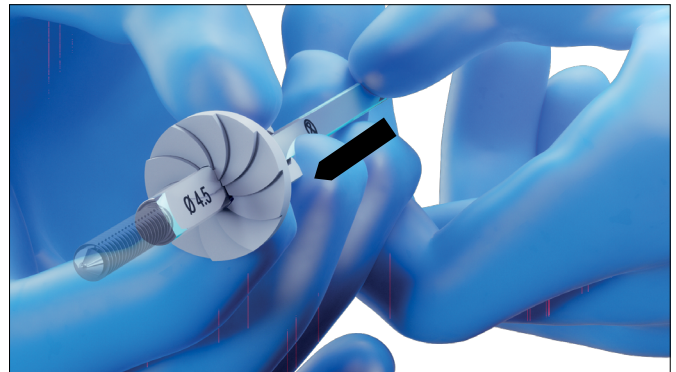

Figure 15C

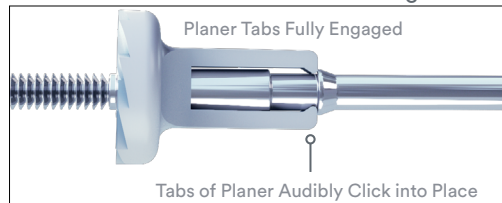

Figure 15D



---

## Step 6: Optional radial neck planing

1. Introduce the conical tip of the Sounder into the center of the canal. (Figure 16)
2. Advance the assembly until the Planer is resting on the bone.
3. With your hand, gently rotate the Planer clockwise to create a smooth contact surface on the radial neck, perpendicular to the longitudinal axis of the radial neck.

### Important:

- The planer is only provided in one diameter. Larger corrections of radial neck angle and/or length may require the use of additional instruments (saws, rongeurs, etc.).
- Do not place thumb on “U” shaped button while Planing or the Sounder may become disengaged from the Handle.

▲ **Precaution:** Avoid excessive planing as this may increase the height of the implant head required.

Figure 16

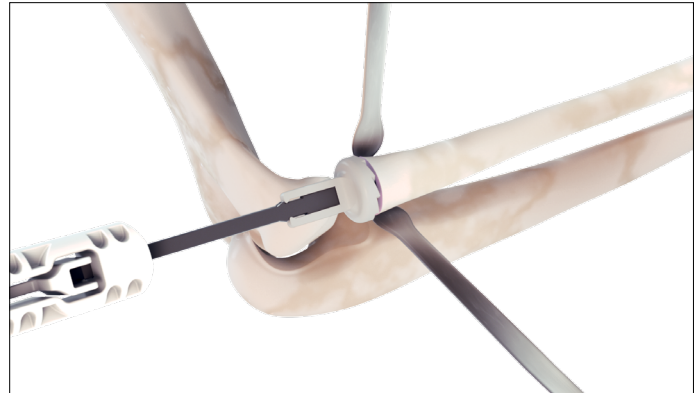



## Step 7: Insert Radiolucent Trial

**Instrument Needed:** Radiolucent Trials\*

\*Radiolucent Trials are part of the Radial Head Replacement Instrument Kit.

1. Select the appropriate Radiolucent Trial diameter based on the previously determined head diameter and head height and the stem diameter corresponding with the appropriate Sounder size. (Figure 17)

Figure 17

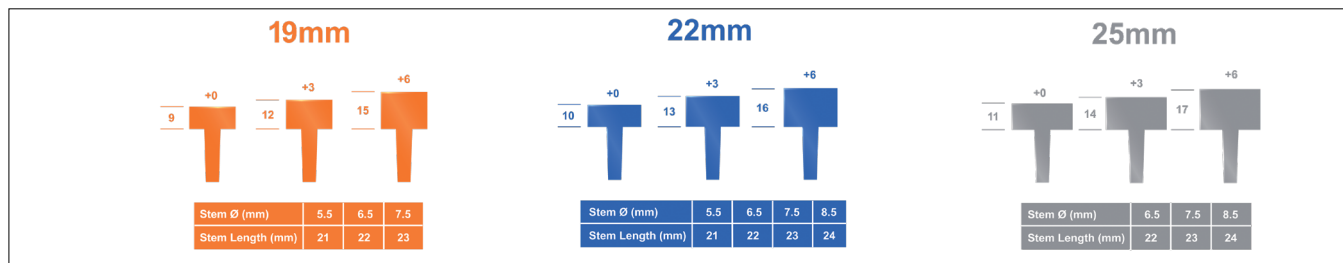

■ **Note:** If the height is unknown, begin with the Trial as Radiolucent Spacers can be added for additional head height. The different head diameters of the Trials and Spacers are indicated by different colors.

2. Using Forceps or Needle Drivers, grab onto the flats located on the side of the Trial to aid with insertion. (Figure 18)

Figure 18

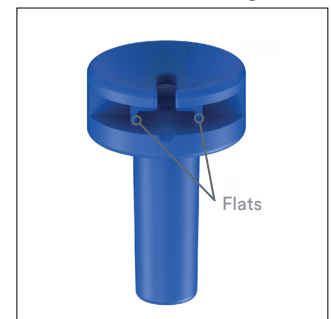

3. Insert the Trial. Depending on the anatomy, the radius may be lifted or retracted to gain access to the medullary canal. (Figure 19)

■ **Notes:** During surgical approach, pay special attention to preserving the Lateral Ulnar Collateral Ligament (LUCL). If the ligament is damaged, repair it after the radial head is replaced to ensure that function and stability is restored.

Figure 19

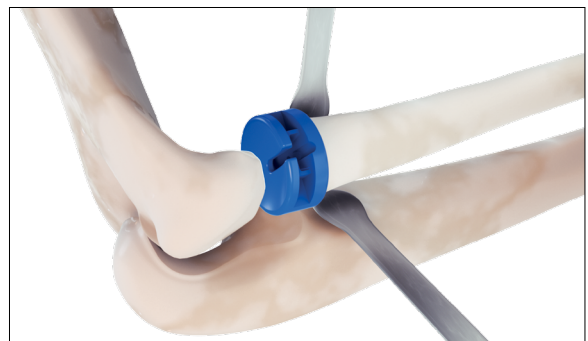

4. After inserting the Trial, confirm rotational motion is unrestricted within the medullary canal of the Radius.

**Important:** If the motion is restricted it is recommended to downsize the stem diameter to allow the implant to more precisely track with the Capitellum.

## Step 8: Adding height with Radiolucent Spacers

### Instrument Needed: Radiolucent Trials and Spacers\*

\*Radiolucent Trials and Spacers are part of the Radial Head Replacement Instrument Kit.

Additional head height can be added by sliding a +3 mm or +6 mm Radiolucent Spacer into the base Trial in-situ. (Figure 20)

1. Use Forceps or Needle Drivers to grasp the Spacer. (Figure 21)
2. Insert the tip of the T-shaped post on the Spacer into the T-shaped slot on the Trial. (Figures 22A and 22B)
3. Advance until the Spacer snaps into place centered above the Trial. (Figure 23)

■ **Note:** The Spacers can be removed by using Forceps or Needle Drivers to grasp the Spacer to allow for evaluation of different head heights or to facilitate removal of the base Trial prior to implant insertion.

▲ **Precaution:** Do not use excessive force when inserting or removing the Radiolucent Trials and Radiolucent Spacers.

Figure 20

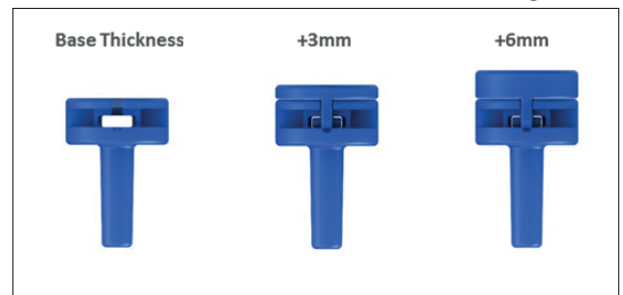

Figure 21



Figure 22A

Figure 22B

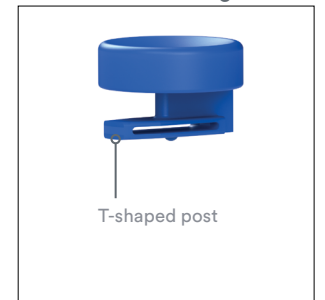
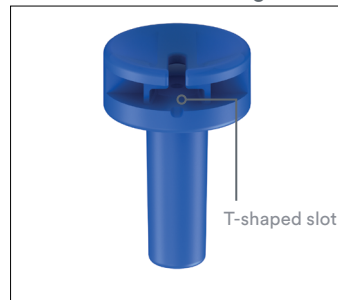
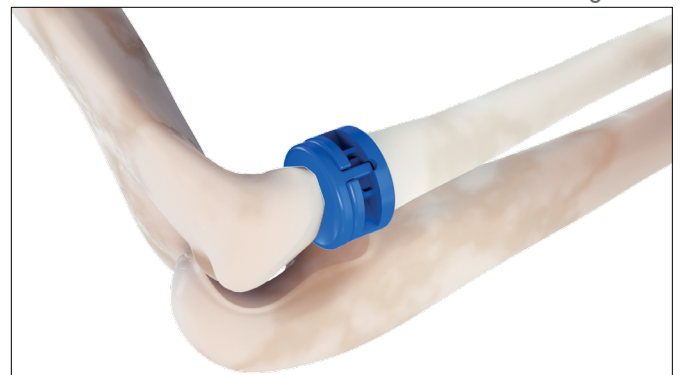

Figure 23



## Step 9: Evaluation of the Radiolucent Trial and Radiolucent Spacer

1. With the selected trial (and spacer) in place assess the ability to accurately close the ligament(s). Ensure that the annular ligament can be approximated without gap.
2. Evaluate stability and range of motion. When evaluating motion, take the elbow through a full arc of flexion, extension, and forearm rotation ensuring that the Trial articulates smoothly with the Capitellum.
3. Evaluate the joint to ensure the implant is not overlengthened or overstuffing. Begin by visually assessing the reconstructed radial head. Confirm the size of the native radial head with the Handle. Next perform an assessment of the PRUJ by visually confirming that the proximal portion (head) of the Radiolucent Trial is flush or immediately distal to the proximal edge of the lesser sigmoid notch throughout the arc of forearm rotation.
4. Assess the joint space for congruency. Visually and radiographically evaluate the radiocapitellar joint space and the ulna-humeral joint space. The medial and lateral side of the ulna-humeral joint space should be congruent. Use x-ray imaging to confirm the center of the radial head bisects the center of the capitellum in the anterior-posterior plane and lateral plane. (Figures 24A and 24B)
5. Evaluate the wrist joint. It may be advisable to evaluate the radius to ulna variance at the wrist with fluoroscopy and concomitantly assess for distal radioulnar joint (DRUJ) instability as is seen in an Essex-Lopresti lesion.
6. Assess the appropriate implant head height by assessing through the full arc of motion. Head height can be adjusted, with the Spacers until the Trial head articulates correctly with the proximal radioulnar joint. Downsize the implant if the optimal size is between available implant sizes. This should avoid overstuffing. Alternatively, if a larger (height) is desirable but the next size up is too tight, 1-2 mm of bone could be removed from the neck and then the larger (height) implant can be reinserted.

**Important:** The final trial selected needs to be assessed to ascertain if the ligaments can be approximated at closure.

▲ **Precaution:** Overstuffing results from over lengthening the radius relative to the ulna and/or increasing radial head diameter relative to the native radial head. Reduced motion and/or pain may ensue, necessitating revision.

Figure 24A

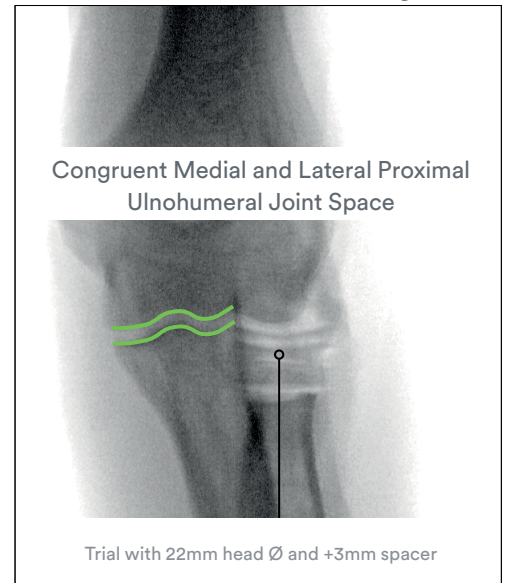

Appropriately Sized Radiolucent Trial

Figure 24B

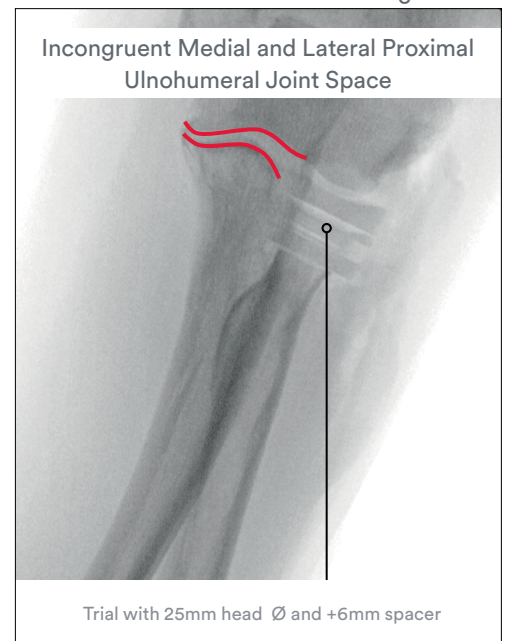

Overstuffed/Oversized Radiolucent Trial

## Step 10: Remove Radiolucent Trials and Spacers

**Instruments Needed:** Radiolucent Trials and Spacers\*

\*Radiolucent Trials and Spacers are part of the Radial Head Replacement Instrument Kit.

1. Using Forceps or Needle Drivers grasp the Spacer.
2. Pull the Spacer outwards to allow the Spacer to disengage from the Trial.
3. Using Forceps or Needle Drivers, grab onto the flats located on the side of the Trial to aid in removal. Depending on the anatomy, the radius may be lifted or retracted to gain access to the medullary canal.
4. Confirm the entire Spacer and Trial have been removed.

▲ **Precaution:** Do not implant the Radiolucent Trial and Radiolucent Spacers. They must be removed before implant insertion.

## Step 11: Open the implant

**Product Needed:** Radial Head Replacement Implant

**Circulating Nurse (non-sterile field):**

1. Open the outer box and remove the inner tray.
2. Peel back the lid and transfer the inner tray onto the sterile field.

**Scrub Nurse (sterile field):**

1. Remove the lid from the inner tray to access the sterile implant.

## Step 12: Insert Implant

**Product Needed:** Radial Head Replacement Implant

1. Insert the selected size Radial Head Replacement into the proximal radius. (Figure 25)

**Important:** You may need to extend and pronate the arm to allow the implant to slide around the capitellum and into place.

■ **Note:** During implant insertion, pay special attention to preserving the Lateral Ulnar Collateral Ligament (LUCL). If the ligament is damaged, repair it after the radial head is replaced to ensure that function and stability is restored.

2. With the selected implant in place ascertain if the ligaments can be approximated at closure. Evaluate stability with range of motion, the length of the elbow and wrist, and congruency and head height per Step 9: Evaluation of the Radiolucent Trial and Radiolucent Spacer located on page 17. (Figures 26A and 26B)

▲ **Precautions:**

- Overstuffing results from over lengthening the radius relative to the ulna and/or inserting too large a radial head. Reduced motion and/or pain may ensue, necessitating revision.
- Do not use excessive force when inserting the Implant.
- Avoid soft tissue impingement when inserting the Implant.
- Radial head subluxation can occur if the annular ligament is not repaired. To prevent subluxation or dislocation of the radial head, ensure ulno-humeral joint stability through anatomic reduction of any ulnar injury and restore global stability of the elbow using appropriate fixation tools.

Figure 25

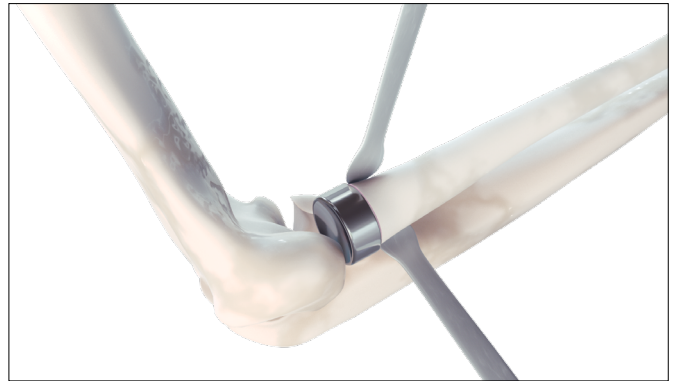
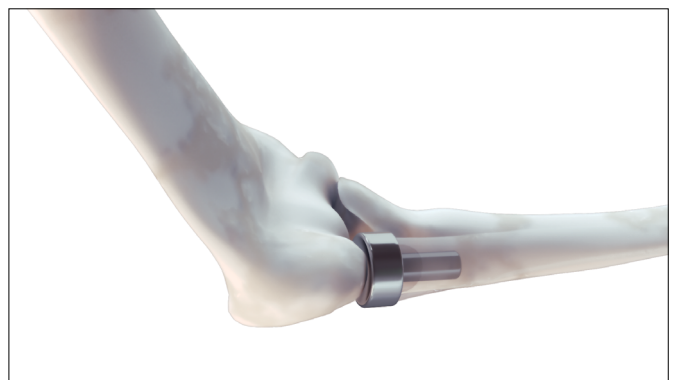

Figure 26A



Figure 26B



# Optional Removal of Planer From Sounder

In certain cases, it may be desirable to remove the Planer from the Sounder. Removal features have been incorporated into the Handle to simplify disassembly.

1. Place the flat side of the Sounder/Planer assembly down onto the eject tabs of the Handle. (Figure 27A and Figure 27B)

■ **Note:** The Planer arms should extend towards the wider opening where the arms can flex outward. This will ensure that the eject tabs will nest inside the cutouts between the Sounder and Planer.

2. Apply firm downward pressure on the Sounder to release the arms of the Planer from the undercut. (Figure 27B) Expect approximately 1mm of motion of the Sounder towards the Handle. (Figure 27C)

3. While maintaining downward pressure, push the Sounder forward away from the Planer. This directional pressure should move the Sounder ribs approximately 1mm away from the Planer. (Figure 27D)

4. The Sounder can now be lifted out of the eject feature and your hand can be used to slide the Planer off the Sounder. (Figure 28)

■ **Notes:**

- The Planer must be moved away from the depth clearing ribs (Figure 28)
- If the Planer is moved toward the ribs the Planer will relock and it will be necessary to repeat the above steps.

5. The Planer can now be reassembled to another Sounder by following Step 5: Optional assembly of Planer on page 13.

Figure 27A

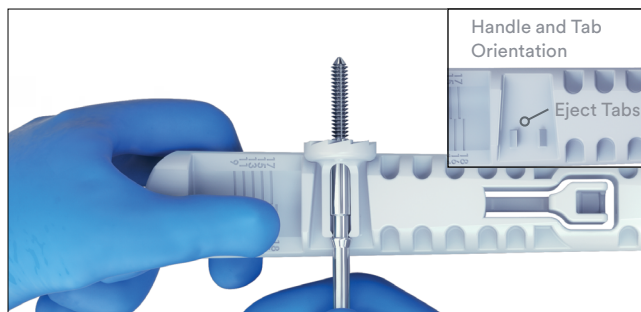

Figure 27B

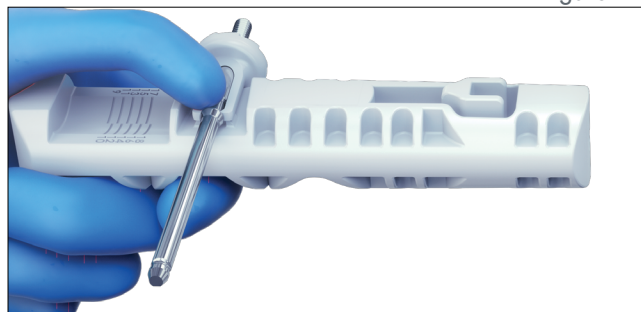

Figure 27C

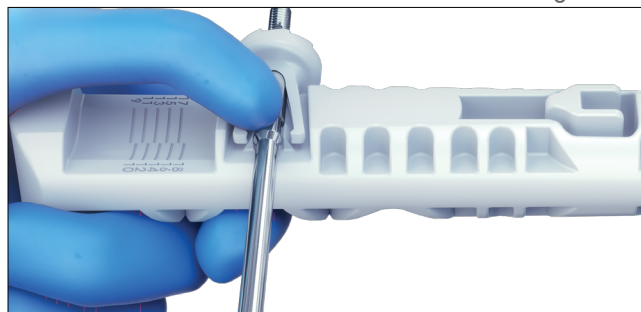

Figure 27D

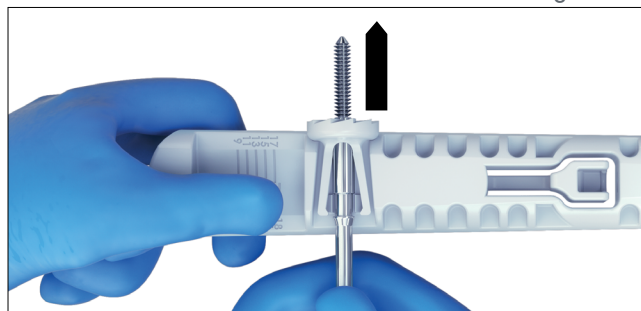
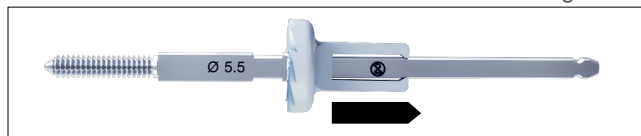

Figure 28



# Implant Removal

---

## Step 1: Remove Implant

The Radial Head Replacement is for permanent implantation and not intended for removal once implanted. However, the treating surgeon may decide to remove the implant based on a risk-benefit evaluation in the following situations:

- Implant breakage, migration, or other clinical failure
  - Pain due to the implant
  - Infection
  - Clinical function is no longer needed
1. If implant removal is deemed necessary, make sure the surgical procedure is initiated with all necessary instruments including a radial head replacement system.
  2. Place the arm into extension.
  3. Using an appropriate instrument, slowly lift the radius until the neck is no longer in line with the capitellum.
  4. Remove the implant and slowly lower the radius back into alignment with the capitellum.

■ **Note:** As at the time of removal, pay special attention to preserving the LUCL. If the ligament is damaged, repair it to ensure that function and stability is restored.

# Potential Adverse Events

---

- Adverse Tissue Reaction, Allergy/Hypersensitivity Reaction
- Infection
- Dislocation
- Poor Joint Mechanics
- Damage to Surrounding Structures (including uninjured ligaments)
- Neurovascular Damage
- Pain or Discomfort
- Bone Damage (including intra-and post-operative bone fracture, bone resorption, or bone necrosis)
- Soft Tissue Damage (including Compartment Syndrome and heterotopic ossification)
- Injury to User
- Symptoms resulting from implant migration, loosening, bending, or breakage

▲ **Precaution:** Heterotopic ossification (HO) is a potential adverse event following elbow fracture. Factors associated with HO formation following elbow fracture are the extent and nature of the injury as well as the time to first surgery after fracture. Other contributing factors may include, but are not limited to, duration of elbow immobilization, infection, and number of post-trauma surgeries.



# Implants

PART NUMBER	DESCRIPTION
09.405.950S	Radial Head w/ Ø19 mm Head, Ø5.5 mm Stem, 9(+0) mm Head Height, Sterile
09.405.953S	Radial Head w/ Ø19 mm Head, Ø5.5 mm Stem, 9(+3) mm Head Height, Sterile
09.405.956S	Radial Head w/ Ø19 mm Head, Ø5.5 mm Stem, 9(+6) mm Head Height, Sterile
09.405.960S	Radial Head w/ Ø19 mm Head, Ø6.5 mm Stem, 9(+0) mm Head Height, Sterile
09.405.963S	Radial Head w/ Ø19 mm Head, Ø6.5 mm Stem, 9(+3) mm Head Height, Sterile
09.405.966S	Radial Head w/ Ø19 mm Head, Ø6.5 mm Stem, 9(+6) mm Head Height, Sterile
09.405.970S	Radial Head w/ Ø19 mm Head, Ø7.5 mm Stem, 9(+0) mm Head Height, Sterile
09.405.973S	Radial Head w/ Ø19 mm Head, Ø7.5 mm Stem, 9(+3) mm Head Height, Sterile
09.405.976S	Radial Head w/ Ø19 mm Head, Ø7.5 mm Stem, 9(+6) mm Head Height, Sterile
09.405.250S	Radial Head w/ Ø22 mm Head, Ø5.5 mm Stem, 10(+0) mm Head Height, Sterile
09.405.253S	Radial Head w/ Ø22 mm Head, Ø5.5 mm Stem, 10(+3) mm Head Height, Sterile
09.405.256S	Radial Head w/ Ø22 mm Head, Ø5.5 mm Stem, 10(+6) mm Head Height, Sterile
09.405.260S	Radial Head w/ Ø22 mm Head, Ø6.5 mm Stem, 10(+0) mm Head Height, Sterile
09.405.263S	Radial Head w/ Ø22 mm Head, Ø6.5 mm Stem, 10(+3) mm Head Height, Sterile
09.405.266S	Radial Head w/ Ø22 mm Head, Ø6.5 mm Stem, 10(+6) mm Head Height, Sterile
09.405.270S	Radial Head w/ Ø22 mm Head, Ø7.5 mm Stem, 10(+0) mm Head Height, Sterile
09.405.273S	Radial Head w/ Ø22 mm Head, Ø7.5 mm Stem, 10(+3) mm Head Height, Sterile
09.405.276S	Radial Head w/ Ø22 mm Head, Ø7.5 mm Stem, 10(+6) mm Head Height, Sterile
09.405.280S	Radial Head w/ Ø22 mm Head, Ø8.5 mm Stem, 10(+0) mm Head Height, Sterile
09.405.283S	Radial Head w/ Ø22 mm Head, Ø8.5 mm Stem, 10(+3) mm Head Height, Sterile
09.405.286S	Radial Head w/ Ø22 mm Head, Ø8.5 mm Stem, 10(+6) mm Head Height, Sterile
09.405.560S	Radial Head w/ Ø25 mm Head, Ø6.5 mm Stem, 11(+0) mm Head Height, Sterile
09.405.563S	Radial Head w/ Ø25 mm Head, Ø6.5 mm Stem, 11(+3) mm Head Height, Sterile
09.405.566S	Radial Head w/ Ø25 mm Head, Ø6.5 mm Stem, 11(+6) mm Head Height, Sterile
09.405.570S	Radial Head w/ Ø25 mm Head, Ø7.5 mm Stem, 11(+0) mm Head Height, Sterile
09.405.573S	Radial Head w/ Ø25 mm Head, Ø7.5 mm Stem, 11(+3) mm Head Height, Sterile
09.405.576S	Radial Head w/ Ø25 mm Head, Ø7.5 mm Stem, 11(+6) mm Head Height, Sterile
09.405.580S	Radial Head w/ Ø25 mm Head, Ø8.5 mm Stem, 11(+0) mm Head Height, Sterile
09.405.583S	Radial Head w/ Ø25 mm Head, Ø8.5 mm Stem, 11(+3) mm Head Height, Sterile
09.405.586S	Radial Head w/ Ø25 mm Head, Ø8.5 mm Stem, 11(+6) mm Head Height, Sterile



# Instrument Kit

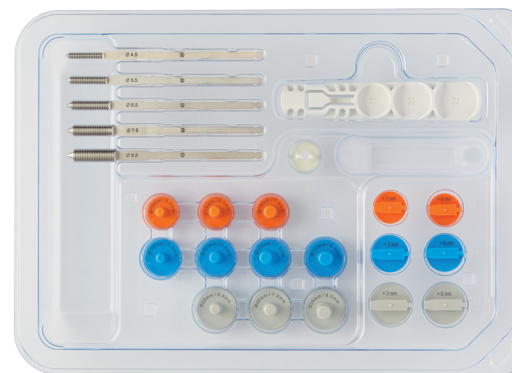

PART NUMBER	DESCRIPTION
03.405.000S	Radial Head Replacement Instrument Kit, Sterile

## Sets

PART NUMBER	DESCRIPTION
01.405.000S	Radial Head Replacement Set, Sterile
01.405.950S	Radial Head Replacement Procedure Set with Ø19 mm Head, Ø5.5 mm Stem, 9(+0) mm Head Height, Sterile
01.405.953S	Radial Head Replacement Procedure Set with Ø19 mm Head, Ø5.5 mm Stem, 9(+3) mm Head Height, Sterile
01.405.956S	Radial Head Replacement Procedure Set with Ø19 mm Head, Ø5.5 mm Stem, 9(+6) mm Head Height, Sterile
01.405.960S	Radial Head Replacement Procedure Set with Ø19 mm Head, Ø6.5 mm Stem, 9(+0) mm Head Height, Sterile
01.405.963S	Radial Head Replacement Procedure Set with Ø19 mm Head, Ø6.5 mm Stem, 9(+3) mm Head Height, Sterile
01.405.966S	Radial Head Replacement Procedure Set with Ø19 mm Head, Ø6.5 mm Stem, 9(+6) mm Head Height, Sterile
01.405.970S	Radial Head Replacement Procedure Set with Ø19 mm Head, Ø7.5 mm Stem, 9(+0) mm Head Height, Sterile
01.405.973S	Radial Head Replacement Procedure Set with Ø19 mm Head, Ø7.5 mm Stem, 9(+3) mm Head Height, Sterile
01.405.976S	Radial Head Replacement Procedure Set with Ø19 mm Head, Ø7.5 mm Stem, 9(+6) mm Head Height, Sterile
01.405.250S	Radial Head Replacement Procedure Set with Ø22 mm Head, Ø5.5 mm Stem, 10(+0) mm Head Height, Sterile
01.405.253S	Radial Head Replacement Procedure Set with Ø22 mm Head, Ø5.5 mm Stem, 10(+3) mm Head Height, Sterile
01.405.256S	Radial Head Replacement Procedure Set with Ø22 mm Head, Ø5.5 mm Stem, 10(+6) mm Head Height, Sterile
01.405.260S	Radial Head Replacement Procedure Set with Ø22 mm Head, Ø6.5 mm Stem, 10(+0) mm Head Height, Sterile
01.405.263S	Radial Head Replacement Procedure Set with Ø22 mm Head, Ø6.5 mm Stem, 10(+3) mm Head Height, Sterile
01.405.266S	Radial Head Replacement Procedure Set with Ø22 mm Head, Ø6.5 mm Stem, 10(+6) mm Head Height, Sterile
01.405.270S	Radial Head Replacement Procedure Set with Ø22 mm Head, Ø7.5 mm Stem, 10(+0) mm Head Height, Sterile
01.405.273S	Radial Head Replacement Procedure Set with Ø22 mm Head, Ø7.5 mm Stem, 10(+3) mm Head Height, Sterile
01.405.276S	Radial Head Replacement Procedure Set with Ø22 mm Head, Ø7.5 mm Stem, 10(+6) mm Head Height, Sterile
01.405.280S	Radial Head Replacement Procedure Set with Ø22 mm Head, Ø8.5 mm Stem, 10(+0) mm Head Height, Sterile
01.405.283S	Radial Head Replacement Procedure Set with Ø22 mm Head, Ø8.5 mm Stem, 10(+3) mm Head Height, Sterile
01.405.286S	Radial Head Replacement Procedure Set with Ø22 mm Head, Ø8.5 mm Stem, 10(+6) mm Head Height, Sterile
01.405.560S	Radial Head Replacement Procedure Set with Ø25 mm Head, Ø6.5 mm Stem, 11(+0) mm Head Height, Sterile
01.405.563S	Radial Head Replacement Procedure Set with Ø25 mm Head, Ø6.5 mm Stem, 11(+3) mm Head Height, Sterile
01.405.566S	Radial Head Replacement Procedure Set with Ø25 mm Head, Ø6.5 mm Stem, 11(+6) mm Head Height, Sterile
01.405.570S	Radial Head Replacement Procedure Set with Ø25 mm Head, Ø7.5 mm Stem, 11(+0) mm Head Height, Sterile
01.405.573S	Radial Head Replacement Procedure Set with Ø25 mm Head, Ø7.5 mm Stem, 11(+3) mm Head Height, Sterile
01.405.576S	Radial Head Replacement Procedure Set with Ø25 mm Head, Ø7.5 mm Stem, 11(+6) mm Head Height, Sterile
01.405.580S	Radial Head Replacement Procedure Set with Ø25 mm Head, Ø8.5 mm Stem, 11(+0) mm Head Height, Sterile
01.405.583S	Radial Head Replacement Procedure Set with Ø25 mm Head, Ø8.5 mm Stem, 11(+3) mm Head Height, Sterile
01.405.586S	Radial Head Replacement Procedure Set with Ø25 mm Head, Ø8.5 mm Stem, 11(+6) mm Head Height, Sterile

■ **Note:** The Radial Head Replacement System includes the Radial Head Replacement Carrying Case, two Radial Head Replacement Instrument Kits and 30 Radial Head Replacement Implants. The Radial Head Replacement Procedure Sets include one Radial Head Replacement Instrument Kit and one Radial Head Replacement Implant.

# Carrying Case

PART NUMBER	DESCRIPTION
60.405.000	Radial Head Replacement Carrying Case



## Additional Sets Available

PART NUMBER	DESCRIPTION
01.333.101	DePuy Synthes Cannulated Compression Headless Screws (CCHS)
141.682 (Stainless Steel) 141.684 (Titanium)	2.4 mm LCP™ Radial Head Plates
01.111.120 (Stainless Steel) 01.111.140 (Titanium)	Modular Mini Fragment LCP™ System
01.302.602 (Stainless Steel) 01.302.604 (Titanium)	Medium External Fixator
01.107.002 (Stainless Steel) 01.107.004 (Titanium)	2.7 mm/3.5 mm Variable Angle LCP™ Elbow System
01.133.201 (Stainless Steel) 01.133.401 (Titanium)	2.7 mm/3.5 mm Non-locking, Locking, and Variable Angle Locking Technology Universal Small Fragment System – Core Set
01.133.202	2.7 mm/3.5 mm Non-locking, Locking, and Variable Angle Locking Technology Universal Small Fragment System – Elbow Tray

■ **Note:** For additional information, please refer to the package insert or [www.e-ifu.com](http://www.e-ifu.com).

For detailed cleaning and sterilization instructions, please refer to [www.depuysynthes.com/hcp/cleaning-sterilization](http://www.depuysynthes.com/hcp/cleaning-sterilization) or sterilization instructions, if provided in the instructions for use.

## References

1. DePuy Synthes Report: See Better Size Better Memo. 10/2/2019. Windchill Document #0000290188.
2. US, EU, APAC, LAT DRG reports combined show that DePuy Synthes is the market leader in trauma.
3. Chien HY, Chen AC, Huang JW, et al. Short-to medium-term outcomes of radial head replacement arthroplasty in posttraumatic unstable elbows: 20 to 70 months follow-up. *Chang Gung Medical Journal*. 2010;33(6):668.
4. Marinelli A, Guerra E, Ritani A, et al. Radial head prosthesis: surgical tips and tricks. *Musculoskelet Surg*. 2017;101(suppl 2):187-196.
5. Acevedo DC, Paxton ES, Kukelyansky I, et al. Radial head arthroplasty: state of the art. *J Am Acad Orthop Surg*. 2014;22(10):633.
6. Szmít J, King GJ, Johnson JA, Langohr DG. The effect of stem fit on the radiocapitellar contact mechanics of a metallic axisymmetric radial head hemiarthroplasty: is loose fit better than rigidly fixed? *J Shoulder Elbow Surg*. 2019;28:2394-2399.
7. DePuy Synthes Report: Radial Head Replacement Literature Review Memo.3/17/2020. Windchill Document #0000292472
8. Flinkkilä T, Kaisto T, Sirniö K, et al. Short-to mid-term results of metallic press-fit radial head arthroplasty in unstable injuries of the elbow. *J Bone Joint Surg Br*. 2012;94(6):805.
9. Allavena C, Delclaux S, Bonnevalle N, et al. Outcomes of bipolar radial head prosthesis to treat complex radial head fractures in 22 patients with a mean follow-up of 50 months. *Orthop Traumatol Surg Res*. 2014;100(7):703.
10. Nestorson J, Josefsson PO, Adolfsson L. A radial head prosthesis appears to be unnecessary in Mason-IV fracture dislocation. *Acta Orthopaedica*. 2017;88(3):315.
11. Rodriguez-Quintana D, Comulada DB, Rodriguez-Quintana N, Lopez-Gonzalez F. Radial head ingrowth anatomic implant versus smooth stem monoblock implant in acute terrible triad injury: a prospective comparative study. *J Orthop Trauma*. 2017;31(9):503-509.
12. Grewal R, MacDermid JC, Faber KJ, et al. Comminuted radial head fractures treated with a modular metallic radial head arthroplasty. Study of outcomes. *The Journal of Bone and Joint Surgery*. American volume 2006;88(10):2192.
13. Duckworth AD, Wickramasinghe NR, Clement ND, et al. Radial head replacement for acute complex fractures: what are the rate and risks factors for revision or removal? *Clin Orthop Relat Res*. 2014;472(7):2136-2143.
14. Moghaddam A, Raven TF, Dremel E, et al. Outcome of radial head arthroplasty in comminuted radial head fractures: short and midterm results. *Trauma Monthly*. 2016;21(1):e20201.
15. Doornberg JN, Parisien R, van Duijn PJ and Ring D. Radial head arthroplasty with a modular metal spacer to treat acute traumatic elbow instability. *J Bone Joint Surg Am*. 2007;89(5):1075.
16. Katthagen JC, Jensen G, Lill H and Voigt C. Monobloc radial head prostheses in complex elbow injuries: results after primary and secondary implantation. *International Orthopaedics*. 2013;37(4):631.

---

Not all products may currently be available in all markets.

Manufactured by:  
**Synthes USA, LLC**  
1101 Synthes Avenue  
Monument, CO 80132

**Synthes GmbH**  
Luzernstrasse 21  
4528 Zuchwil, Switzerland

To order (USA): 800-523-0322  
To order (Canada): 844-243-4321

Note: For recognized manufacturer, refer to the product label.

Please refer to the instructions for use for a complete list of, indications, contraindications, warnings and precautions.



[www.depuysynthes.com](http://www.depuysynthes.com)

© DePuy Synthes 2020, 2022. All rights reserved.  
10366766 Rev. D 07/22

Please also refer to the package insert(s) or other labelling associated with the devices identified in this brochure for additional information.

CAUTION: Federal Law restricts these devices to sale by or on the order of a physician.

Some devices listed in this technique guide may not have been licensed in accordance with Canadian law and may not be for sale in Canada. Please contact your sales consultant for items approved for sale in Canada.