



stryker®

Trauma & Extremities

T2

# Humeral Nailing System

Operative Technique

Humeral Fractures



# T2 Humeral Nailing System

## Contributing Surgeons

### **Rupert Beickert, M.D.**

Senior Trauma Surgeon  
Murnau Trauma Center  
Murnau  
Germany

### **Rosemary Buckle, M.D.**

Orthopaedic Associates, L.L.P.  
Clinical Instructor  
University of Texas Medical School  
Houston, Texas  
USA

### **Prof. Dr. med. Volker Bühren**

Chief of Surgical Services  
Medical Director of Murnau Trauma Center  
Murnau  
Germany

### **Michael D. Mason, D.O.**

Assistant Professor of Orthopaedic Surgery  
Tufts University School of Medicine  
New England Baptist Bone & Joint Institute  
Boston, Massachusetts  
USA

---

This publication sets forth detailed recommended procedures for using Stryker Osteosynthesis devices and instruments.

It offers guidance that you should heed, but, as with any such technical guide, each surgeon must consider the particular needs of each patient and make appropriate adjustments when and as required.

A workshop training is recommended prior to first surgery.

All non-sterile devices must be cleaned and sterilized before use. Follow the instructions provided in our reprocessing guide (L24002000). Multi-component instruments must be disassembled for cleaning. Please refer to the corresponding assembly/disassembly instructions.

See package insert (L22000007) for a complete list of potential adverse effects, contraindications, warnings and precautions. The surgeon must discuss all relevant risks, including the finite lifetime of the device, with the patient, when necessary.

#### **Warning:**

**Fixation Screws:**  
Stryker Osteosynthesis bone screws are not approved or intended for screw attachment or fixation to the posterior elements (pedicles) of the cervical, thoracic or lumbar spine.

# Contents

	<b>Page</b>
<b>1. Technical Details</b>	<b>4</b>
Technical Details	4
Instrument Coding	4
<b>3. Indications, Precautions and Contraindications</b>	<b>5</b>
<b>4. Pre-operative Planning</b>	<b>6</b>
<b>5. Locking Options</b>	<b>7</b>
<b>6. Operative Technique – Antegrade Technique</b>	<b>9</b>
Patient Positioning and Fracture Reduction	9
Incision	9
Entry Point	10
Unreamed Technique	11
Reamed Technique	11
Nail Selection	13
Nail Insertion	14
Guided Locking Mode (via Target Device)	15
Static Locking Mode	16
Freehand Distal Locking	19
End Cap Insertion	21
Dynamic Locking Mode	21
Apposition/Compression Locking Mode	22
Advanced Locking Mode	24
Nail Removal	25
<b>7. Operative Technique – Antegrade Technique</b>	<b>26</b>
Patient Positioning	26
Incision	26
Entry Point	27
Unreamed Technique	27
Reamed Technique	28
Nail Selection	29
Nail Insertion	29
Guided Locking Mode (via Target Device)	32
Static Locking Mode	33
Freehand Proximal Locking	36
End Cap Insertion	37
Dynamic Locking Mode	37
Apposition/Compression Locking Mode	38
Advanced Locking Mode	40
Nail Removal	41

# Technical Details

## Nails

Diameter 7–9mm  
 Sizes 140–320mm

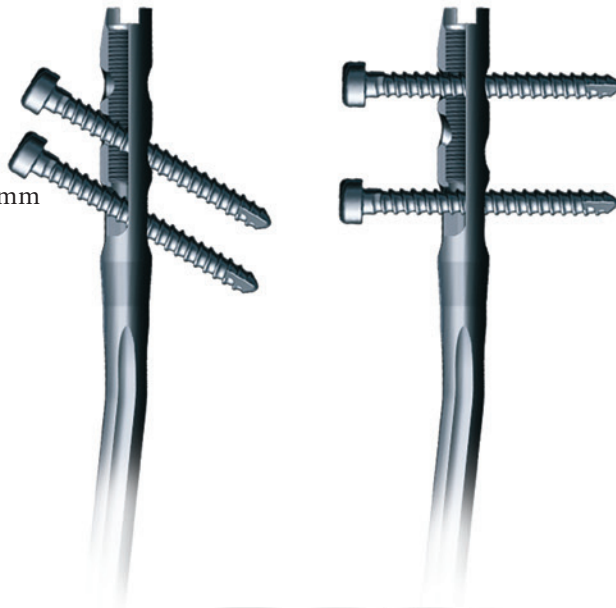

## Humerus Advanced Compression Screw

(Diameter = 6mm)



## 4.0mm Fully Threaded Locking Screws

L = 20–60mm

## 4.0mm Partially Threaded Locking Screws

(Shaft Screws)  
 L = 20–60mm

## End Caps

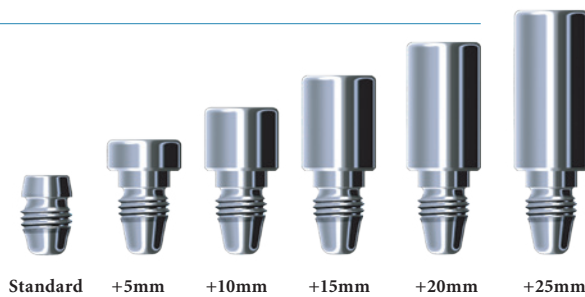

## Instrument Coding

Symbol coding on the instruments indicates the type of procedure, and must not be mixed.

### Symbol

- Square = Long instruments
- ▲ Triangular = Short instruments

### Drills

Drills feature color coded rings:

3.5mm = Orange

For 4.0mm Fully Threaded Locking Screws and for the second cortex when using 4.0mm Partially Threaded Locking Screws (Shaft Screws).

4.0mm = Grey

For the first cortex when using 4.0mm Partially Threaded Locking Screws (Shaft Screws).



\* Compression Range

Total Length of Slot Less Screw Diameter (-) 10mm  
 Maximum Movement of Screw 4mm  
 6mm

# Indications, Precautions and Contraindications

## Indications

- The T2 Humeral Nail is intended to provide temporary stabilization of various types of fractures, malunions and nonunions of the humerus.
- The nails are inserted using an opened or closed technique and can be static, dynamic and compression locked.
- The subject and predicate devices are indicated for use in the humerus.
- Types of fractures include, but not limited to fractures of the humeral shaft, non-unions, malalignments, pathological humeral fractures, and impending pathological fractures.

## Precautions

Stryker Osteosynthesis systems have not been evaluated for safety and use in MR environment and have not been tested for heating or migration in the MR environment, unless specified otherwise in the product labeling.



## Relative Contraindications

The physician's education, training and professional judgement must be relied upon to choose the most appropriate device and treatment. Conditions presenting an increased risk of failure include:

- Any active or suspected latent infection or marked local inflammation in or about the affected area.
- Compromised vascularity that would inhibit adequate blood supply to the fracture or the operative site.
- Bone stock compromised by disease, infection or prior implantation that can not provide adequate support and/or fixation of the devices.
- Material sensitivity, documented or suspected.
- Obesity. An overweight or obese patient can produce loads on the implant that can lead to failure of the fixation of the device or to failure of the device itself.
- Patients having inadequate tissue coverage over the operative site.
- Implant utilization that would interfere with anatomical structures or physiological performance.
- Any mental or neuromuscular disorder which would create an unacceptable risk of fixation failure or complications in postoperative care.
- Other medical or surgical conditions which would preclude the potential benefit of surgery.

# Pre-operative Planning

An X-Ray Template (1806-0003) is available for pre-operative planning.

Thorough evaluation of pre-operative radiographs of the affected extremity is critical. Careful radiographic examination can help prevent intra-operative complications.

If X-Rays show a very narrow intramedullary canal in the distal part of the humerus, retrograde humeral nailing is not possible.

The proper nail length when inserted antegrade should extend from subchondral bone proximally, to 1cm above the olecranon fossa distally.

The retrograde nail length is determined by measuring the distance from 1cm above the olecranon fossa to the center of the humeral head.

In either approach, the surgeon should consider the apposition/compression feature of the T2 Humeral Nail, knowing that 6mm of active apposition/compression is possible, prior to determining the final length of the implant.

**Note:**

**Check with local representative regarding availability of nail sizes.**

**T2 Humeral Nail**

Scale: 1,07 : 1  
7% Magnification

**stryker®**

Trauma

**Nail diameters**

- Ø7mm
- Ø8mm
- Ø9mm

Nail length range for all diameters : 140 - 320 mm

Locking screw positions before compression.  
For compression and advanced locking procedure please follow Surgical-Technique.

Antegrade options		
Static/Oblique	Static/Transverse	Dynamic/Compression

Retrograde options	
Static/Transverse	Dynamic/Compression

140mm

160mm

180mm

190mm

200mm

210mm

220mm

230mm

240mm

250mm

260mm

270mm

280mm

290mm

300mm

310mm

320mm

Manufacturer:

Stryker Trauma GmbH  
Prof.-Küntzcher Str. 1-6  
24232 Schönkirchen  
Germany

CE

Cat.Nr.:1806-0003/Rev.2

# Locking Options

Antegrade



Static Mode transverse

Static Mode oblique

Retrograde

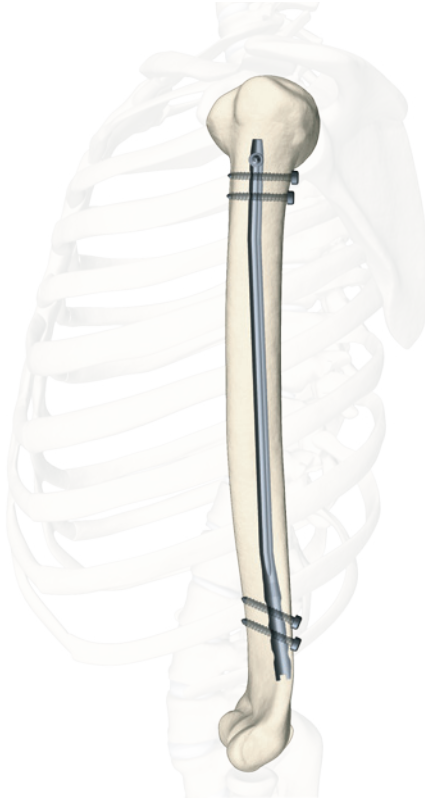
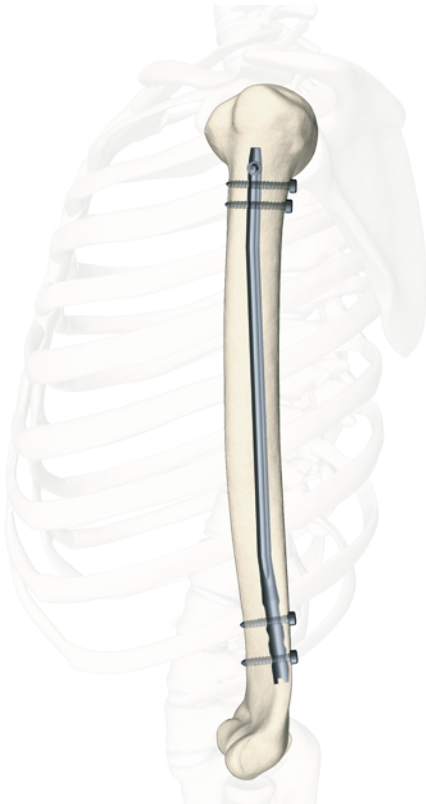

# Locking Options



**Dynamic Mode**



**Apposition/Compression Mode**



**Advanced Locking Mode**

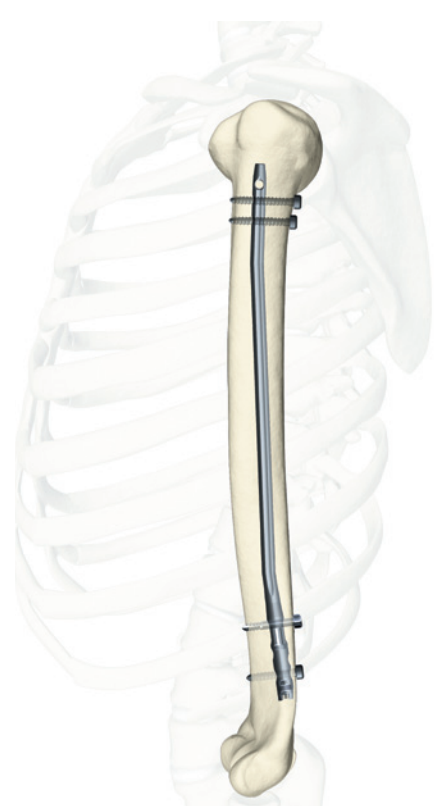
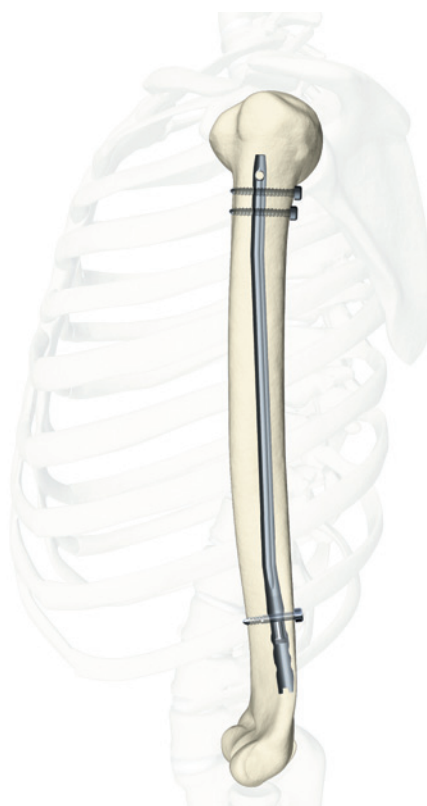
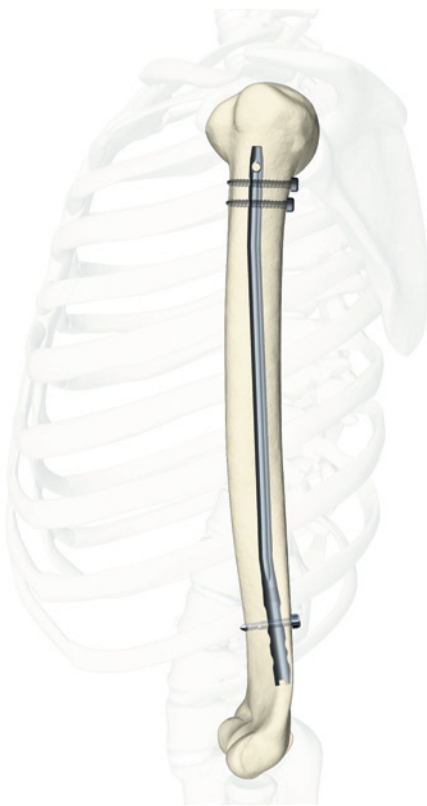



# Operative Technique – Antegrade Technique

## Patient Positioning and Fracture Reduction

The patient is placed in a semireclined “beach chair position” or supine on a radiolucent table. Patient positioning should be checked to ensure that imaging and access to the entry site are possible without excessive manipulation of the affected extremity (Fig.1). The image intensifier is placed at the legside of the patient; the surgeon is positioned at the headside.

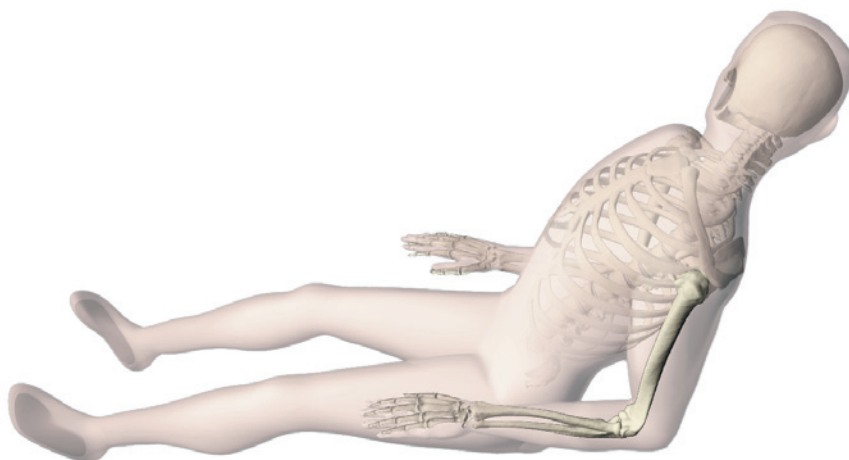

Fig. 1

## Incision

A small incision is made in line with the fibers of the deltoid muscle anterolateral to the acromion. The deltoid is split to expose the subdeltoid bursa. Palpate to identify the anterior and posterior margins of the greater tuberosity and supraspinatus tendon. The supraspinatus tendon is then incised in line with its fibers (Fig. 2).

The real rotation of the proximal fragment is checked (inversion or reversion), considering that the entry point is at the tip of the greater tubercle. If the proximal fragment is inverted, the entry point is more anterior. If the proximal fragment is in external rotation, the entry point is more lateral. It is recommended to localize the entry point under image intensifier control, also palpating the bicipital groove, the portal is about 10mm posterior to the biceps tendon. This will make the entry portal concentric to the medullary canal.



Fig. 2

# Operative Technique – Antegrade Technique

## Entry Point

The entry point is made with the Curved, cannulated Awl (1806-0040) (Fig. 3). The 2.5×800mm Ball Tip Guide Wire (1806-0083S) is then introduced through the awl under image intensification into the metaphysis, central to the long axis of the humerus.

Alternatively, the optional Crown Drill (1806-2020) may be used over the K-Wire with Washer (1806-0051S) for entry point preparation. The K-Wire will help to guide the Crown Drill centrally (Fig. 3a).

Then, the 3×285mm K-Wire (1806-0050S) is introduced under image intensification into the metaphysis, central to the long axis of the humerus.

The cannulated Ø10mm Rigid Reamer (1806-2010) may be used over the K-Wire and the proximal metaphysis should be drilled to a depth of at least 6cm.

### Note:

**During opening the entry portal with the Awl, dense cortex may block the tip of the Awl. An Awl Plug (1806-0032) can be inserted through the Awl to avoid penetration of bone debris into the cannulation of the Awl shaft.**

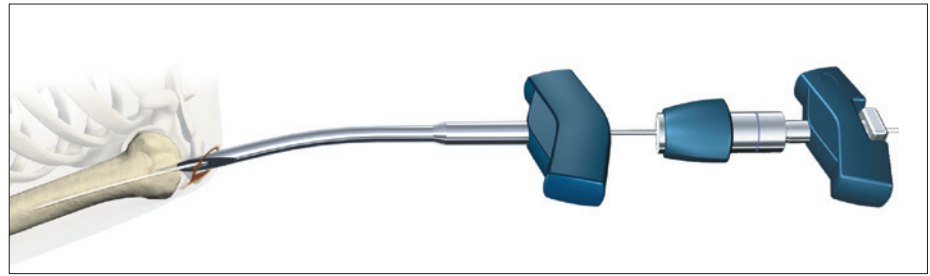

**Fig. 3**

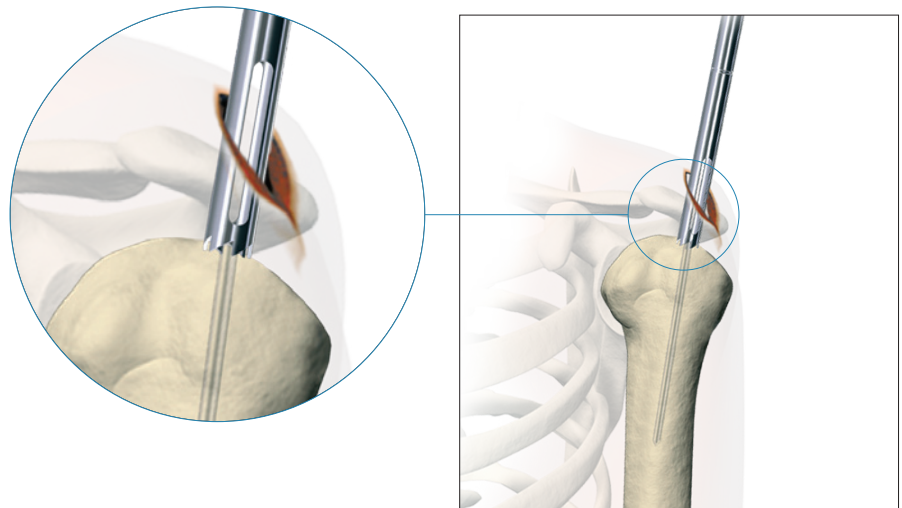

**Fig. 3a**

# Operative Technique – Antegrade Technique

## Unreamed Technique

If an unreamed technique is preferred, the nail may be inserted over the 2.2×800mm Smooth Tip Guide Wire (1806-0093S) (Fig. 4).



Fig. 4

## Reamed Technique

For reamed techniques, the 2.5×800mm Ball Tip Guide Wire (1806-0083S) is inserted across the fracture site. The Reduction Rod (1806-0363) may be used as a fracture reduction tool to facilitate Guide Wire insertion across the fracture site (Fig. 5).

Reaming is commenced in 0.5mm increments until cortical contact is appreciated. Final reaming should be 1mm–1.5mm larger than the diameter of the nail to be used.

The Guide Wire Pusher can be used to help keep the Guide Wire in position during reamer shaft extraction. The metal cavity at the end of the handle pushed on the end of the power tool facilitates to hold the Guide Wire in place when starting to pull the power tool. When close to the Guide Wire end place the Guide Wire Pusher with its funnel tip to the end of the power tool cannulation. While removing the power tool the Guide Wire Pusher will keep the Guide Wire in place (Fig. 6 & 7).

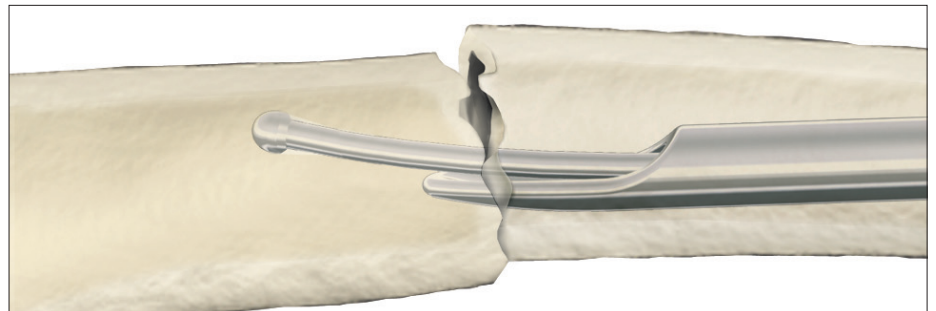

Fig. 5

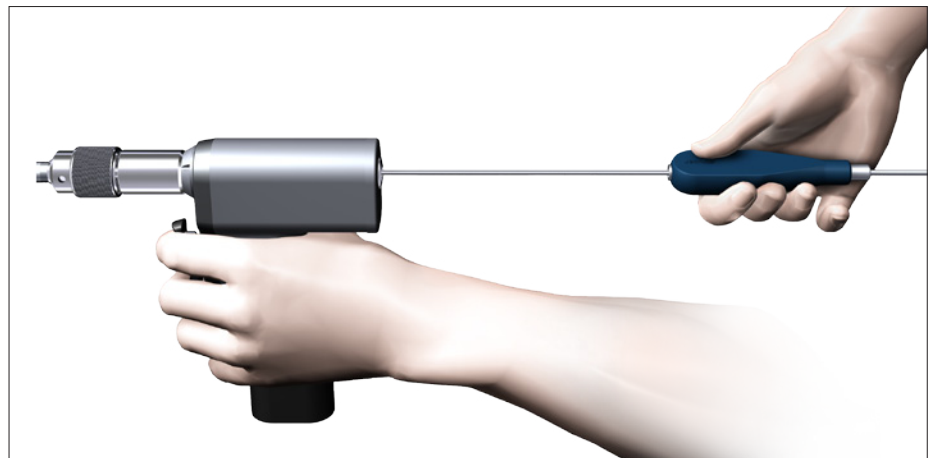

Fig. 6

# Operative Technique – Antegrade Technique

**Note:**

- **Humeral Nails cannot be inserted over the 2.5mm Ball Tip Guide Wire. The Ball Tip Guide Wire must be exchanged for the 2.2mm Smooth Tip Guide Wire prior to nail insertion.**
- **Use the Teflon Tube (1806-0073S) for the Guide Wire exchange.**

When reaming is completed, the Teflon Tube (1806-0073S) should be used to exchange the Ball Tip Guide Wire (1806-0083S) with the Smooth Tip Wire (1806-0093S) for nail insertion (Fig. 8 and 9).

An unreamed technique can be considered in cases, where the medullary canal has the appropriate diameter. In these cases, the nail can be introduced over the 2.2×800mm Smooth Tip Guide Wire (1806-0093S).

**Note:**

- **X-Ray Templates should be used pre-operatively to determine the canal size radiographically.**
- **The driving end of 7mm nails is 8mm.**

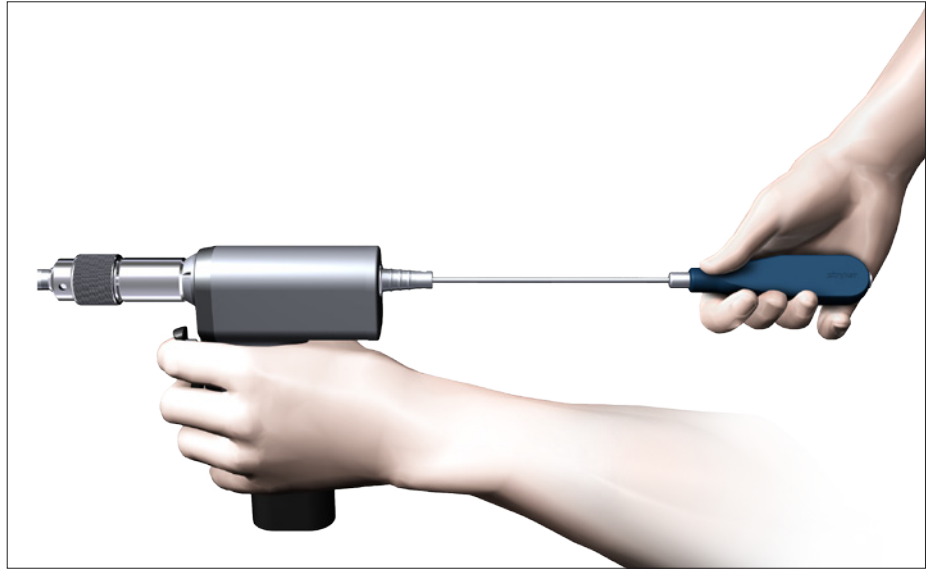

**Fig. 7**

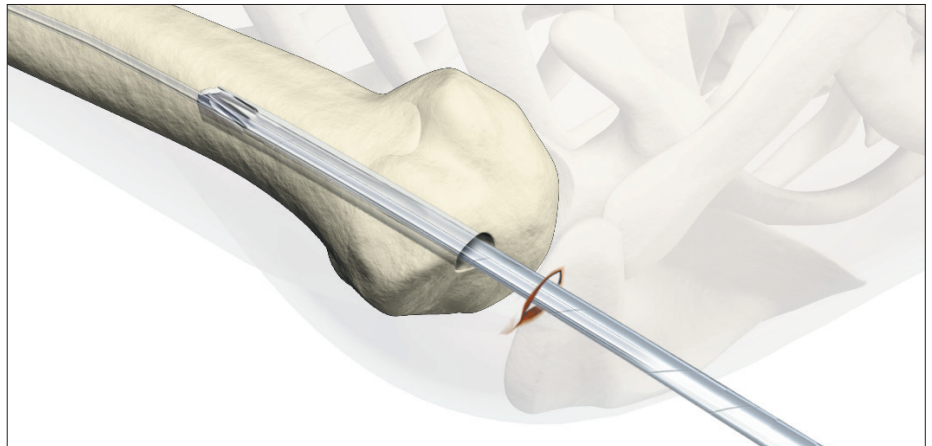

**Fig. 8**

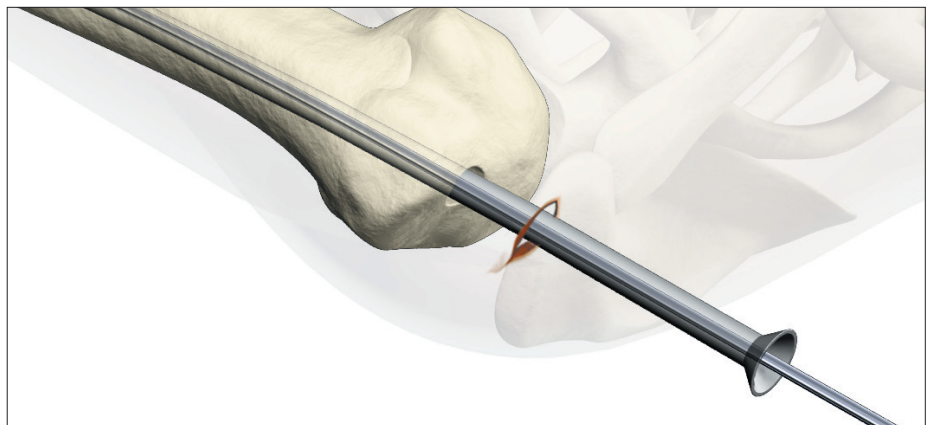
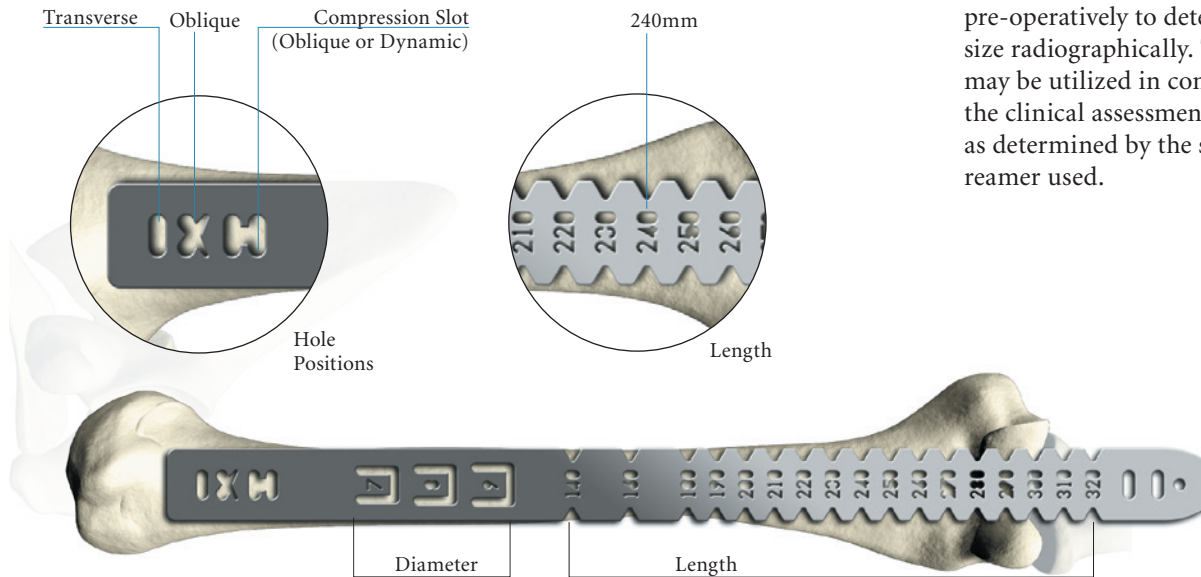

**Fig. 9**

# Operative Technique – Antegrade Technique

## Nail Selection

The X-Ray Template should be used pre-operatively to determine the canal size radiographically. This information may be utilized in conjunction with the clinical assessment of canal size as determined by the size of the last reamer used.



**Fig. 10**

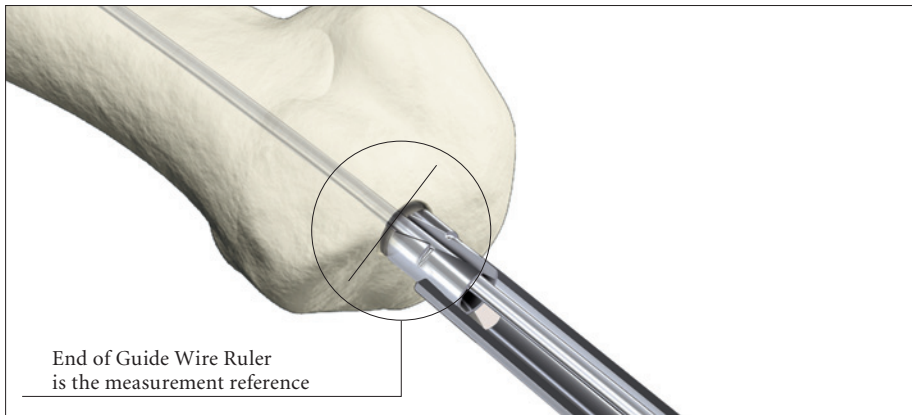

**Fig. 11**

### Diameter

The diameter of the selected nail should be 1mm–1.5mm smaller than the last reamer used.

### Length

Nail length may be determined with the X-Ray Ruler (Fig. 10). The Guide Wire Ruler (1806-0022) may be used by placing it on the Guide Wire reading the correct nail length at the end of the Guide Wire on the Guide Wire Ruler (Fig. 11 and 12). Confirm the position of the tip of the Guide Wire prior to measurement.

### Note:

If the fracture is suitable for apposition/compression, the implant selected should be 6–10mm shorter than measured to help avoid migration of the nail beyond the insertion site.

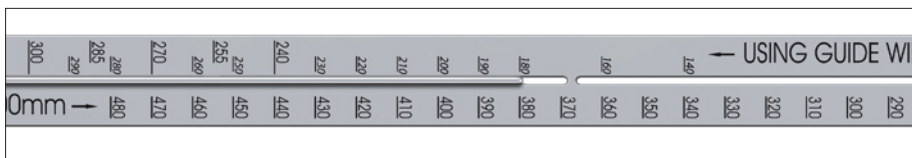

**Fig. 12**

The Guide Wire Ruler can be easily folded and unfolded.



# Operative Technique – Antegrade Technique

## Nail Insertion

The selected nail is assembled onto the Target Device (1806-0143) with the Nail Holding Screw (1806-0163). Tighten the Nail Holding Screw securely with the Insertion Wrench (1806-0135) so that it does not loosen during nail insertion (Fig. 13).



Fig. 13

### Note:

**Prior to nail insertion please check correct alignment by inserting a drill bit through the assembled Tissue Protection and Drill Sleeve placed in the required holes of the targeting device.**

Upon completion of reaming and Guide Wire exchange, the appropriate size nail is ready for insertion. Advance the nail through the entry point past the fracture site to the appropriate level.

Gentle rotation of the nail may be necessary to start the nail insertion. The nail should be advanced with manual pressure. Aggressive use of the slotted hammer can result in additional fractures. If the nail does not advance easily, a check with image intensification should be made to see if the nail angle is too steep resulting in the nail impinging on the medial cortex.

The Slotted Hammer (1806-0170) can be used to insert the nail over the Guide Wire. DO NOT hit the Target Device.

### Note:

**A chamfer is located on the working end of the nail to denote the end under X-Ray. Three circumferential grooves are located on the insertion post at 2mm, 6mm, and 10mm from the driving end of the nail (Fig. 14-16). Depth of insertion may be visualized with the aid of fluoroscopy.**

The 3×285mm K-Wire may be inserted through the Target Device which identifies the junction of the nail and insertion post (Fig. 17).

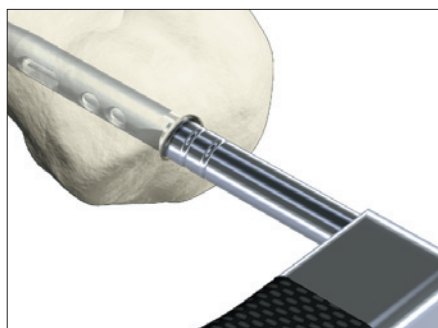

Fig. 14

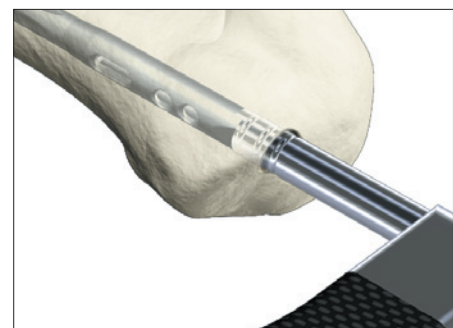

Fig. 15



Fig. 16



Fig. 17

# Operative Technique – Antegrade Technique

## Guided Locking Mode (via Target Device)

Prior to guided locking via the Target Device, the Nail Holding Screw must be firmly tightened using the Insertion Wrench, to ensure that the nail is in correct alignment with the Target Device.

The Target Device is designed to provide four options for guided locking (Fig. 18.1–18.4).

In the Static Oblique Locking Mode, the two static holes closest to the end of the nail may be used for static oblique (30°) locking (Fig. 18.1).

- 1. Static**
- 2. Static**

In the Static Transverse Locking Mode, the next static hole and the dynamic hole are used for static transverse locking (Fig. 18.2).

- 3. Static**
- 4. Dynamic**

In the Controlled Dynamic Mode, and/or Controlled Apposition/Compression Mode, the dynamic hole is required (Fig. 18.3).

- 4. Dynamic**

In the Advanced Locking Mode, the dynamic hole is required. After utilizing compression with the Advanced Compression Screw, the static hole is used (Fig. 18.4).

- 4. Dynamic**
- 3. Static**

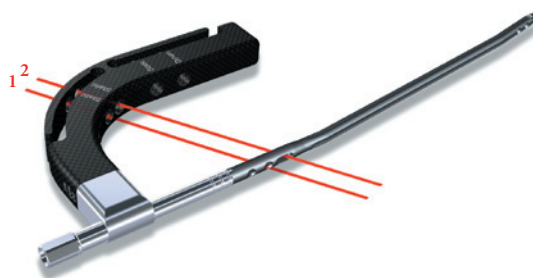

**Fig. 18.1**

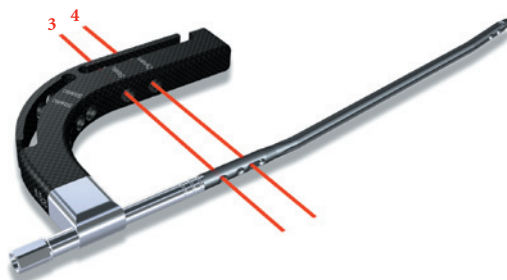

**Fig. 18.2**

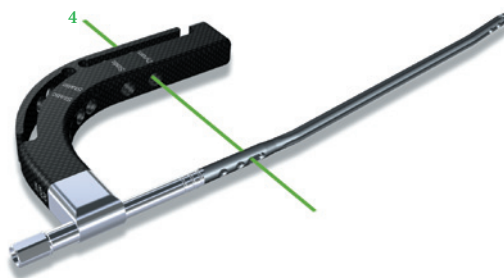

**Fig. 18.3**

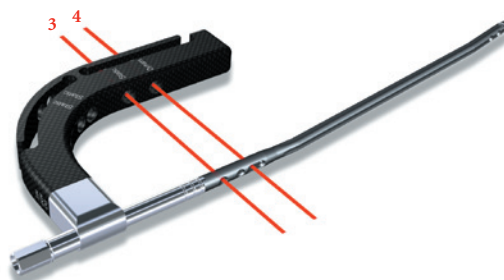
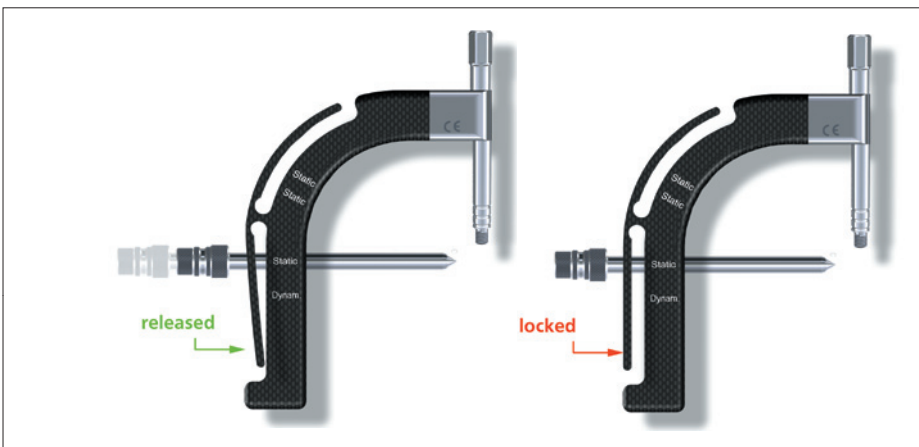

**Fig. 18.4**

The Short Tissue Protection Sleeve, (1806-0180), together with the Short Drill Sleeve (1806-0210) and the Short Trocar (1806-0310), are inserted into the Target Device by pressing the safety clip (Fig. 19).

The friction lock mechanism is designed to keep the sleeve in place and prevent it from falling out. It is designed to also keep the sleeve from sliding during screw measurement.

To release the Tissue Protection Sleeve, the safety clip must be pressed again.



**Fig. 19**

# Operative Technique – Antegrade Technique

## Static Locking Mode

### Static Transverse Locking Mode

In unstable or comminuted fractures, the nail should be used as a standard interlocking nail. Static locking of the distal holes will help maintain the length of the bone and the rotational stability of the fracture.

The Short Tissue Protection Sleeve, together with the Short Drill Sleeve and the Short Trocar, are positioned through the static locking hole on the Target Device. A small skin incision is made, and the assembly is pushed through until it is in contact with the lateral cortex of the humerus (Fig.20).

#### Note:

**Especially in the proximal humerus, use image intensification to help ensure the Tissue Protection Sleeve is flush with the cortex or you could lose 1–2mm of screw measurement accuracy.**

The Trocar is removed while the Tissue Protection Sleeve and the Drill Sleeve remain in position.

For accurate drilling and easy determination of screw length, use the center-tipped,  $\text{Ø}3.5 \times 230\text{mm}$  calibrated Drill (1806-3540S). The centered Drill is forwarded through the Drill Sleeve and pushed onto the cortex.

After the first cortex is drilled to the appropriate level the screw length may be read directly off of the Drill at the end of the Drill Sleeve (Fig. 21).

#### Caution:

**Make sure the Tissue Protection Sleeve/Drill Sleeve Assembly is seated on bone prior to selecting final screw length.**

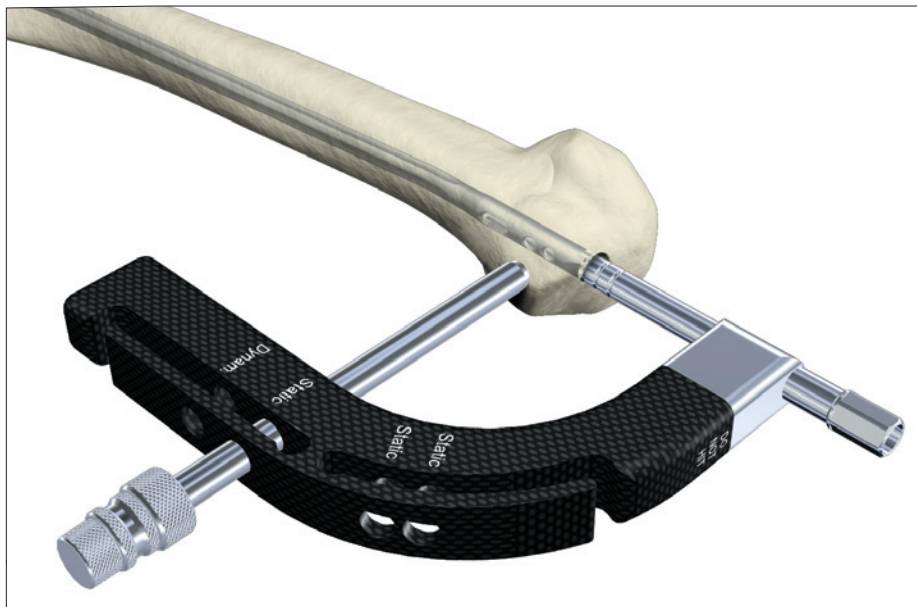

Fig.20

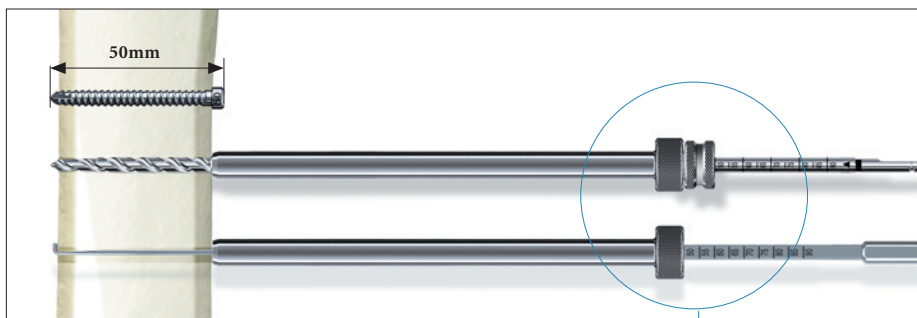

Fig.21





# Operative Technique – Antegrade Technique

## Warning:

Do not drill through the far cortex as this will penetrate the joint.

## Note:

- The position of the end of the Drill as it relates to the far cortex is equal to where the end of the screw will be. Therefore, if the end of the Drill is 3mm beyond the far cortex, the end of the screw will also be 3mm beyond.
- The Screw Gauge, Short, is calibrated so that with the bend at the end pulled back flush with the far cortex, the screw tip will end 3mm beyond the far cortex (Fig. 21).

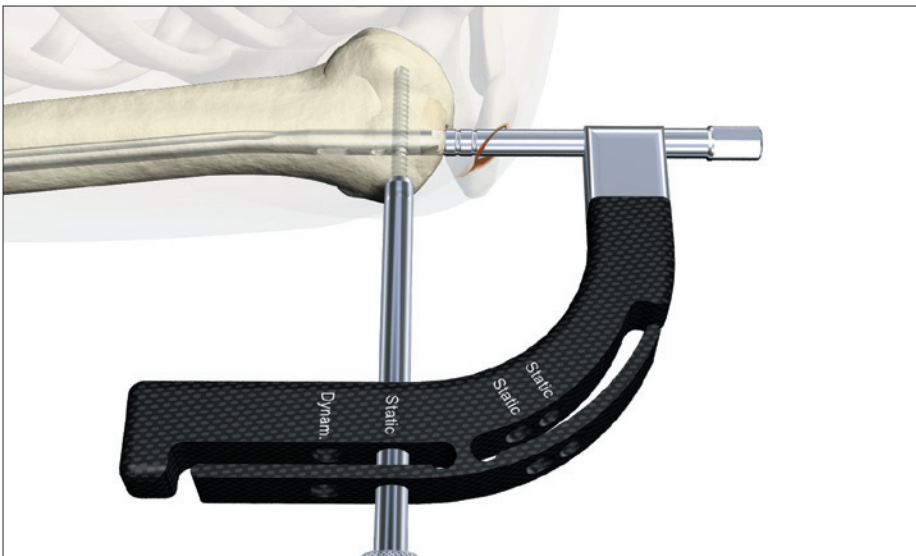

Fig. 22

When the Drill Sleeve is removed, the correct 4.0mm Locking Screw is inserted through the Tissue Protection Sleeve using the Screwdriver Shaft, Short (1806-0222) with the Teardrop Handle (702429, Fig. 22). The screw is near its proper seating position when the groove around the shaft of the screwdriver is approaching the end of the Tissue Protection Sleeve.

Use image intensification to confirm screw position through the nail as well as screw length.

Repeat the locking procedure for the other statically positioned Locking Screw (Fig. 23).

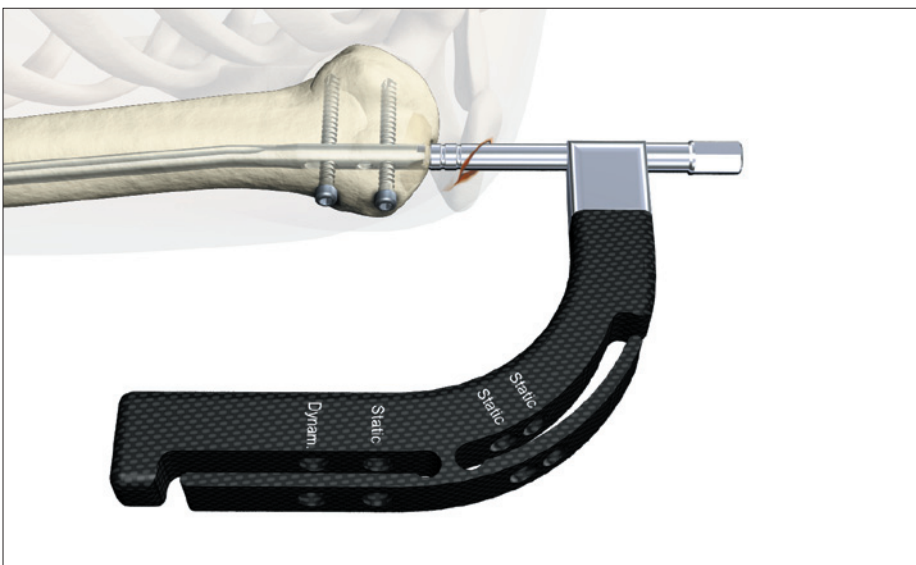

Fig. 23

## Caution:

The coupling of Elastosil handles contains a mechanism with one or multiple ball bearings. In case of applied axial stress on the Elastosil handle, those components are pressed into the surrounding cylinder resulting in a complete blockage of the device and possible bending.

To avoid intra-operative complications and secure long-term functionality, we mandate that Elastosil handles be used only for their intended use.

DO NOT HIT any Elastosil handles.

# Operative Technique – Antegrade Technique

## Static Oblique Locking Mode

In cases that may be locked in the Static Oblique Locking Mode, place the assembly of the Tissue Protection Sleeve together with the Drill Sleeve and the Trocar through the Oblique static hole closest to the driving end of the nail (Fig. 24). Refer to the procedure for Locking Screw insertion.

The second Fully Threaded Locking Screw is inserted through the static hole (Fig. 25) next to the first hole, and placed in an oblique manner through the oblong hole of the nail (Fig. 26).

Confirm screw position and screw length with image intensification.

## Washer

The Washer, either Rectangular or Round, may be used in cases of osteoporotic bone to bridge the bone gap and allow for enhanced purchase of the Locking Screw (Fig. 27).

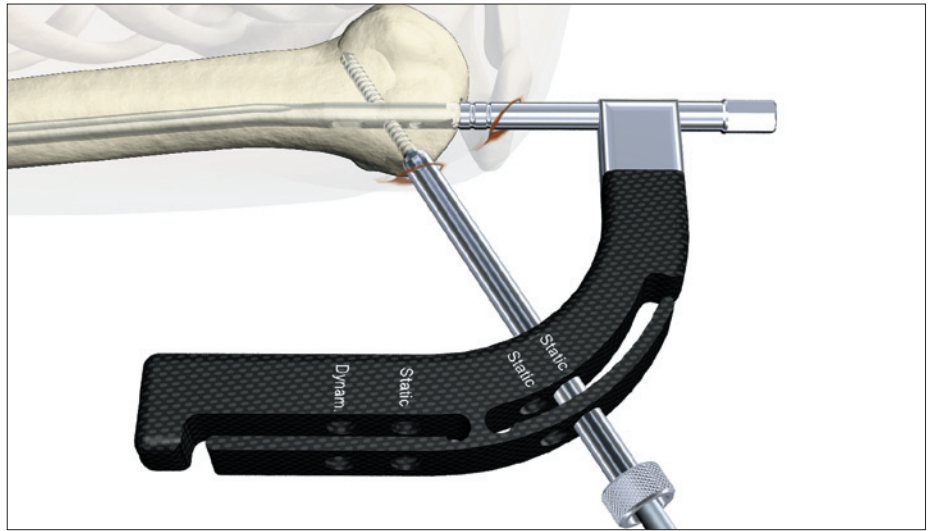

Fig. 24

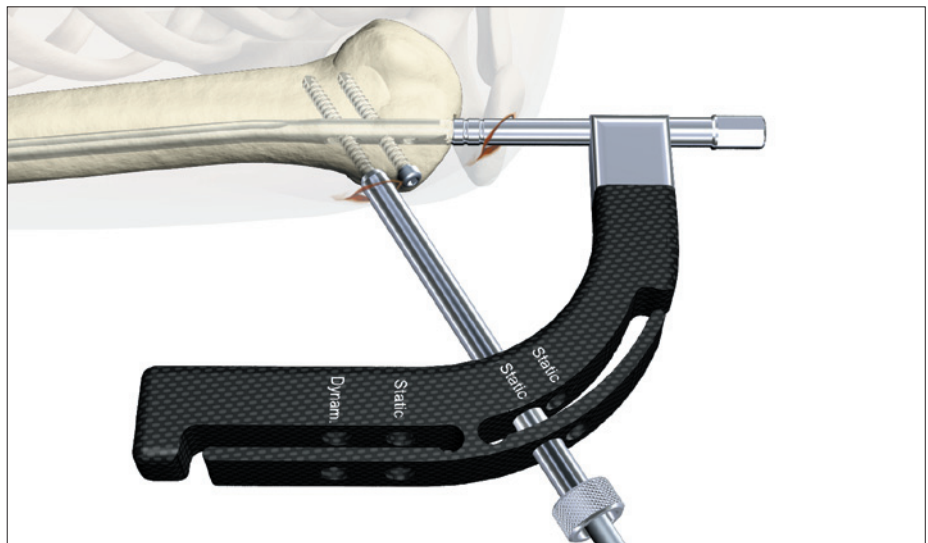

Fig. 25



Fig. 27

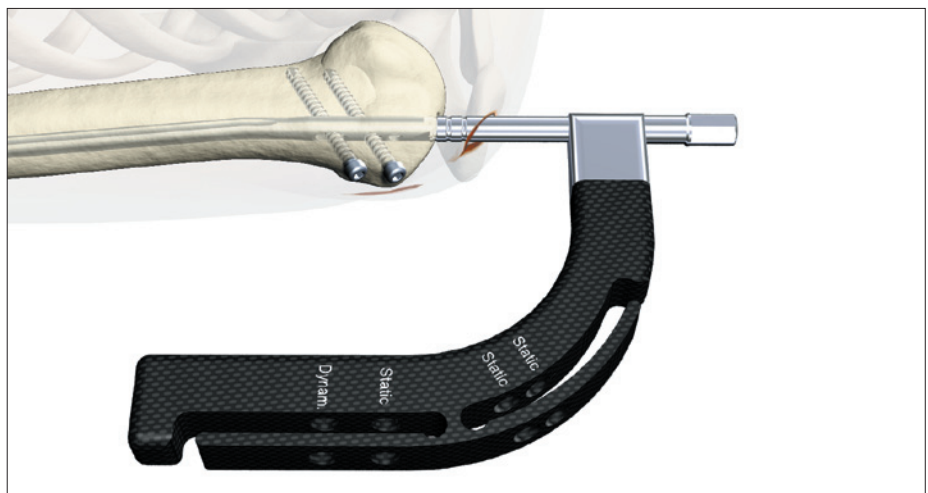

Fig. 26

# Operative Technique – Antegrade Technique

## Freehand Distal Locking

The freehand technique is used to insert Locking Screws into both the A/P and M/L holes in the nail. Rotational alignment must be checked prior to distal locking.

Multiple locking techniques and radio-lucent drill devices are available for freehand locking. The critical step with any freehand locking technique, proximal or distal, is to visualize a perfectly round locking hole with the C-Arm.

### Caution:

**In order to avoid damage to the neurovascular structure, a limited open approach should be considered.**

The center-tipped  $\text{Ø}3.5 \times 230\text{mm}$  Drill (1806-3540S), or the optional  $\text{Ø}3.5 \times 130\text{mm}$  Drill (1806-3550S), is held at an oblique angle to the center of the locking hole (Fig. 28 and 29). Upon X-Ray verification, the Drill is placed perpendicular to the nail and drilled through the anterior cortex.

Confirm these views in both the A/P and M/L planes by X-Ray.

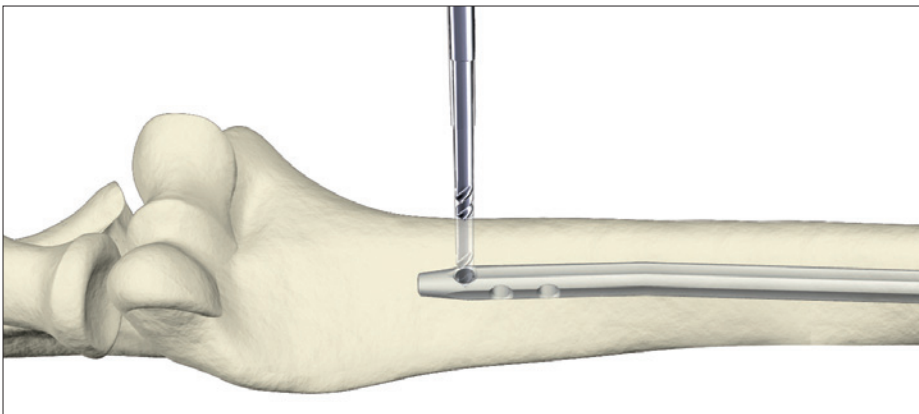

Fig. 28

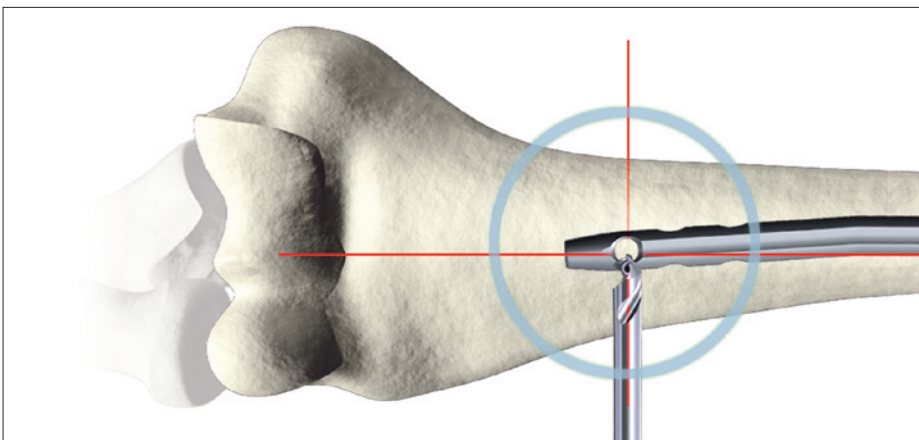

Fig. 29

# Operative Technique – Antegrade Technique

After drilling both cortices, the screw length may be read directly off of the Screw Scale, Short (1806-0360) at the orange color coded ring on the center-tipped Drill (Fig. 30). As with proximal locking (Fig.21, p.16), the position of the end of the drill is equal to the end of the screw as they relate to the far cortex.

Routine Locking Screw insertion is employed with the assembled Short Screwdriver Shaft and the Teardrop Handle.

If possible, the distal humerus should be locked with two Fully Threaded Locking Screws. Additional locking of the M/L hole(s) is possible if the image intensifier can be adjusted (Fig. 31).

**Note:**

**Use image intensification to confirm screw position through the nail as well as screw length.**

Alternatively, the Screw Gauge can be used to measure the screw length.

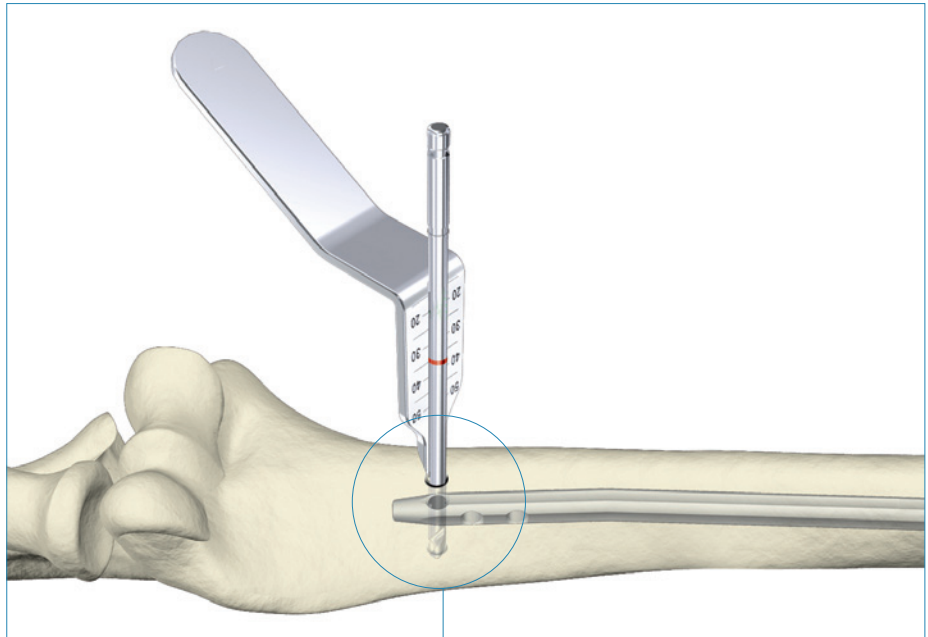

**Fig. 30**

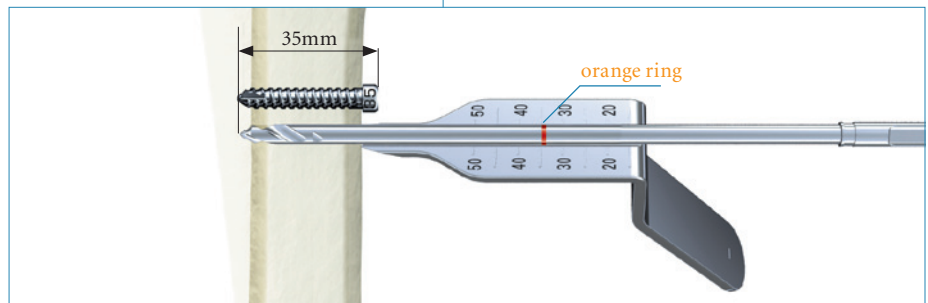

**Fig. 30a**

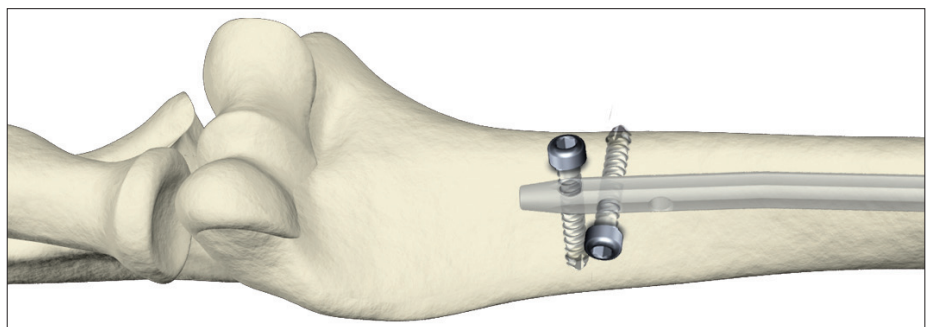

**Fig. 31**

# Operative Technique – Antegrade Technique

## End Cap Insertion

After removal of the Target Device, an End Cap is used to reduce the potential for bony ingrowth into the proximal threads of the nail.

End Caps are available in six sizes (Fig. 32).

The End Cap is inserted with the Short Screwdriver Shaft assembled on the Teardrop Handle after intra-operative radiographs show satisfactory reduction and hardware implantation (Fig. 33). Fully seat the End Cap to minimize the potential for loosening.

### Caution:

**To avoid impingement, carefully select the length of the End Cap.**

Close the wound using standard technique.



**Fig. 32**

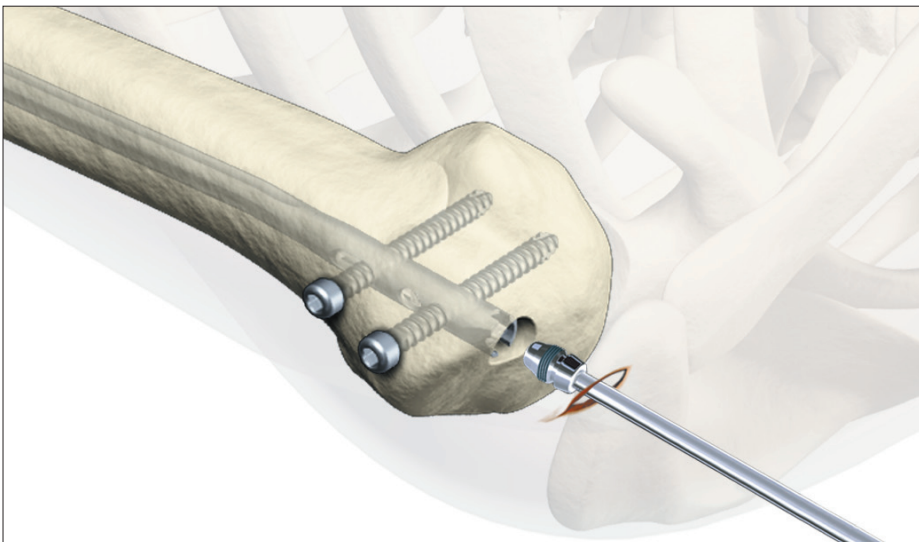

**Fig. 33**

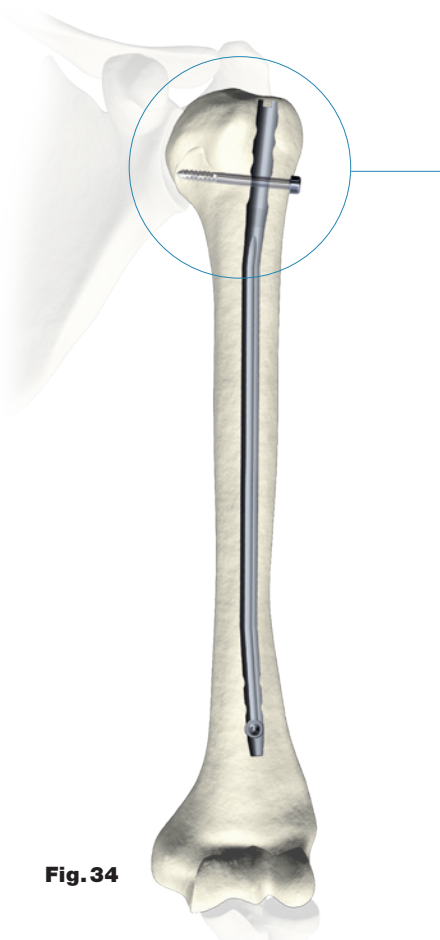

**Fig. 34**

## Dynamic Locking Mode

When the fracture profile permits, controlled dynamic locking may be utilized for transverse or axially stable fractures.

Antegrade dynamization is performed by statically locking the nail distally.

The guided Partially Threaded Locking Screw (Shaft Screw) is then placed in the dynamic position of the oblong hole. This allows the nail to move, and the fracture to settle while torsional stability is maintained (Fig. 34).

# Operative Technique – Antegrade Technique

## Apposition/Compression Locking Mode

The antegrade T2 Humeral Nail provides the option to treat a humerus fracture with active mechanical apposition/compression prior to leaving the operating room.

**Note:**

**Distal freehand static locking must be performed prior to applying active, controlled apposition/compression to the fracture site.**

If active apposition/compression is required, a Partially Threaded Locking Screw (Shaft Screw) is inserted via the Target Device in the dynamic position of the oblong hole. This will allow for a maximum of 6mm of active, controlled apposition/compression. In order to insert the Partially Threaded Locking Screw (Shaft Screw), drill both cortices with the  $\text{Ø}3.5 \times 230\text{mm}$  Drill (1806-3540S). Next, the near cortex ONLY is overdrilled with the  $\text{Ø}4.0 \times 180\text{mm}$  Drill (1806-4000S).

**Note:**

**After the opposite cortex is drilled with the  $\text{Ø}3.5 \times 230\text{mm}$  drill, the correct screw length can be read directly off of the calibrated Drill at the end of the Drill Sleeve.**

After the Partially Threaded Locking Screw (Shaft Screw) is inserted, the Nail Holding Screw is removed, leaving the insertion post intact with the nail (Fig. 35). This will act as a guide for the Compression Screw. The Compression Screw with the Compression Screwdriver Shaft (1806-0263) assembled on the Teardrop Handle is inserted through the insertion post (Fig. 36).

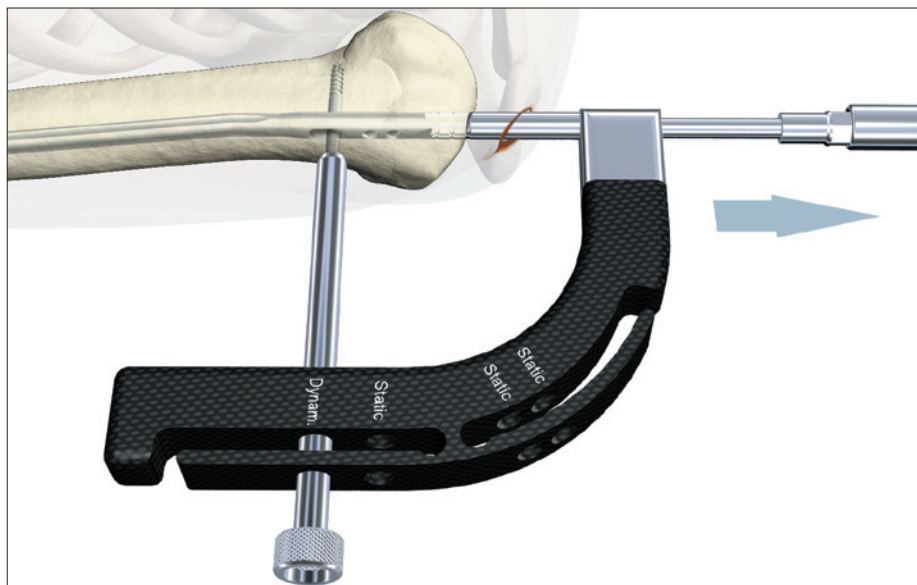

Fig. 35

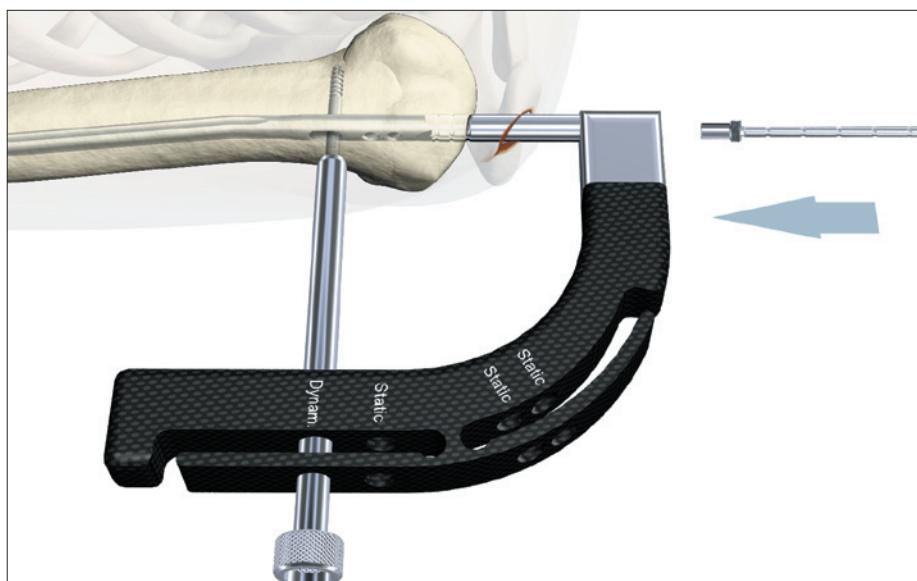

Fig. 36

# Operative Technique – Antegrade Technique

## Note:

It may be easier to “insert” the Compression Screw prior to fully seating the nail. Once the nail tip has cleared the fracture site, the Guide Wire (if used) is withdrawn. With the proximal portion of the nail not fully seated and extending out of the bone, the Advanced Compression Screw is inserted. Care should be taken that the shaft of the Compression Screw does not extend into the area of the oblong hole.

The Short Tissue Protection Sleeve is removed and the Compression Screw is gently tightened utilizing the two-finger technique (Fig. 37). As the Compression Screw is advanced against the 4.0mm Partially Threaded Locking Screw (Shaft Screw), it draws the distal fracture segment towards the fracture site, employing active apposition/compression (Fig. 38). Image intensification will enable the surgeon to visualize active apposition/compression. Some bending of the transverse Partially Threaded Locking Screw (Shaft Screw) may be seen.

## Note:

- Apposition/compression must be carried out under X-Ray control. Over-compression may cause the nail or the Partially Threaded Locking Screw (Shaft Screw) to fail.
- When compressing the nail, the implant must be inserted a safe distance from the entry point to accommodate for the 6mm of active compression. The three grooves on the insertion post are designed to help attain accurate insertion depth of the implant.

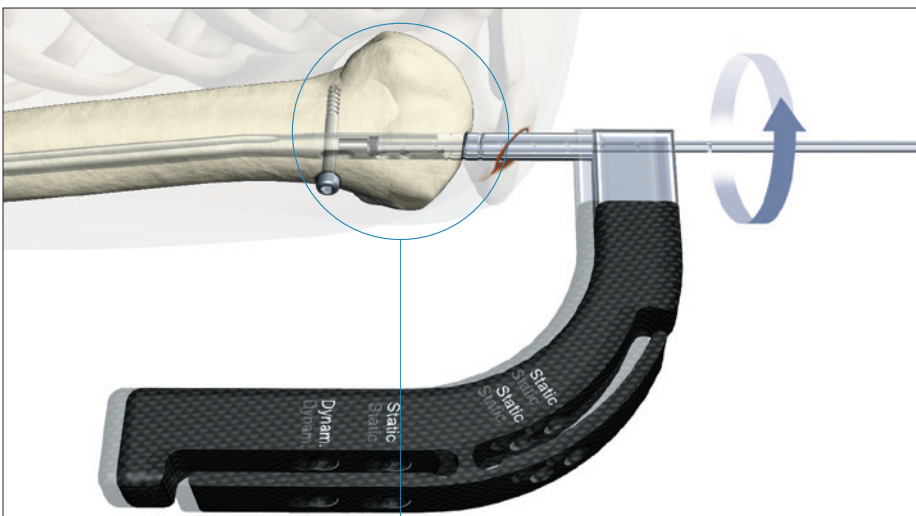

Fig. 37

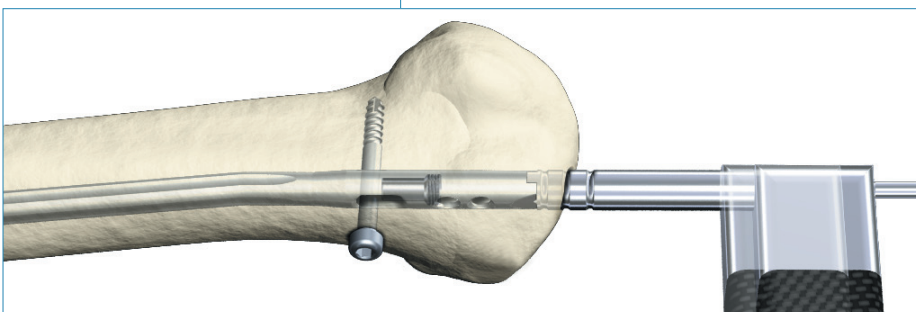

Fig. 38

# Operative Technique – Antegrade Technique

## Advanced Locking Mode

In order to achieve additional fixation and to reduce the load on the Partially Threaded Locking Screw (Shaft Screw), the design of the T2 Humeral Nail provides the opportunity to insert a Fully Threaded Locking Screw in the other transverse hole at the driving end of the nail after apposition/compression is utilized.

Prior to guided locking via the Target Device, the Nail Holding Screw must be tightened using the Insertion Wrench.

Fix the Advanced Compression Screw on the self-retaining Compression Screwdriver Shaft. Remove the Nail Holding Screw leaving the Target Device in place (Fig. 39). Advance the Compression Screw through the Target Device until the desired amount of compression is achieved. Visualize depth of insertion with the aid of fluoroscopy (Fig. 40).

### Note:

**As previously described, it may be easier to insert the Compression Screw prior to fully seating the nail.**

To reattach the Target Device to the nail, detach the Teardrop Handle from the Compression Screwdriver Shaft and screw the Nail Holding Screw over the Compression Screwdriver Shaft into its required position.

To insert the second transverse Fully Threaded Locking Screw, follow the locking procedure for static locking (Fig. 41).

Finally, an End Cap should be inserted, as shown on page 21.

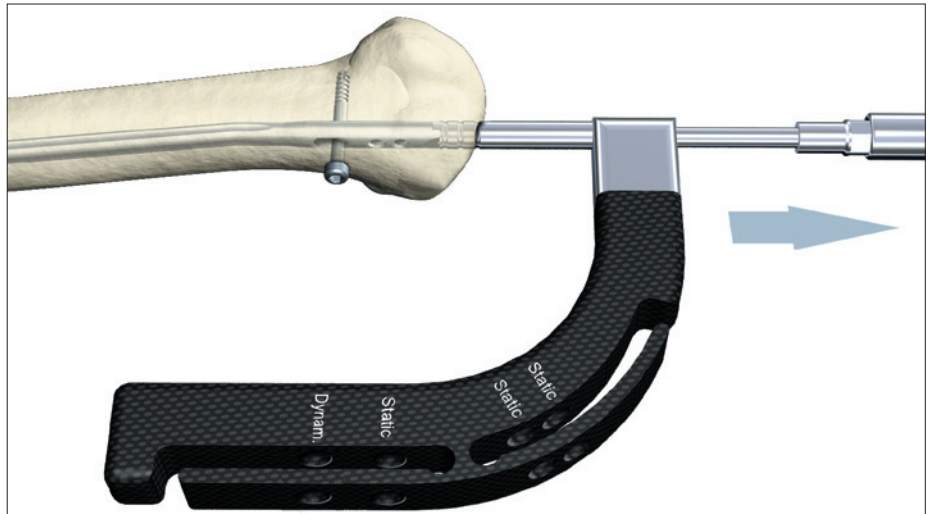

Fig. 39

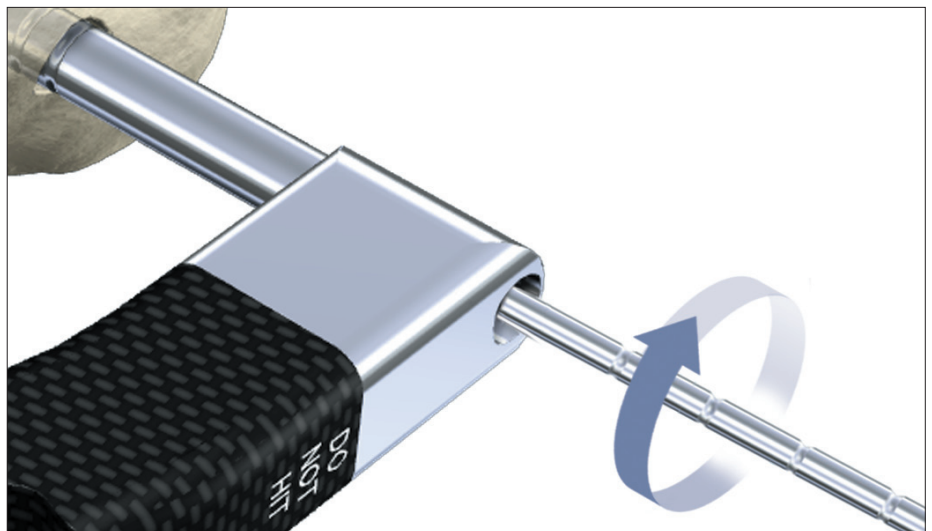

Fig. 40

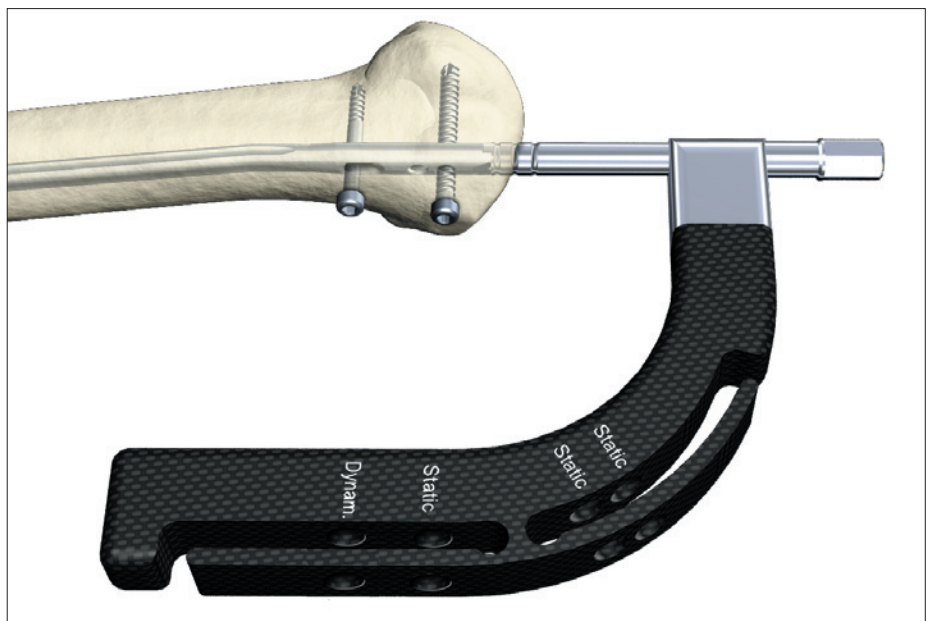

Fig. 41



# Operative Technique – Antegrade Technique

## Nail Removal

Nail removal is mostly an elective procedure. If used, first remove the End Cap with the Short Screwdriver Shaft and the Teardrop Handle (Fig. 42). If Advanced Locking Mode was utilized, the most proximal screw is extracted first, allowing access to the compression screw. Next, disengage the Advanced Compression Screw from the Fully Threaded Locking Screw (Shaft Screw) by turning the Compression Screwdriver one full turn in a counter-clockwise direction (Fig. 43).

**Note:**

**There is no need to attempt to remove the Advanced Compression Screw from the nail, which with the nail implanted, may be difficult.**

The Universal Rod, Short is inserted into the driving end of the nail before all Locking Screws are removed with the Short Screwdriver Shaft and the Teardrop Handle (Fig. 43).

**Note:**

**Attaching of the Universal Rod to the nail first will reduce the potential for nail migration, then the locking screws may be removed safely.**

The Slotted Hammer is used to extract the nail in a controlled manner (Fig. 44).

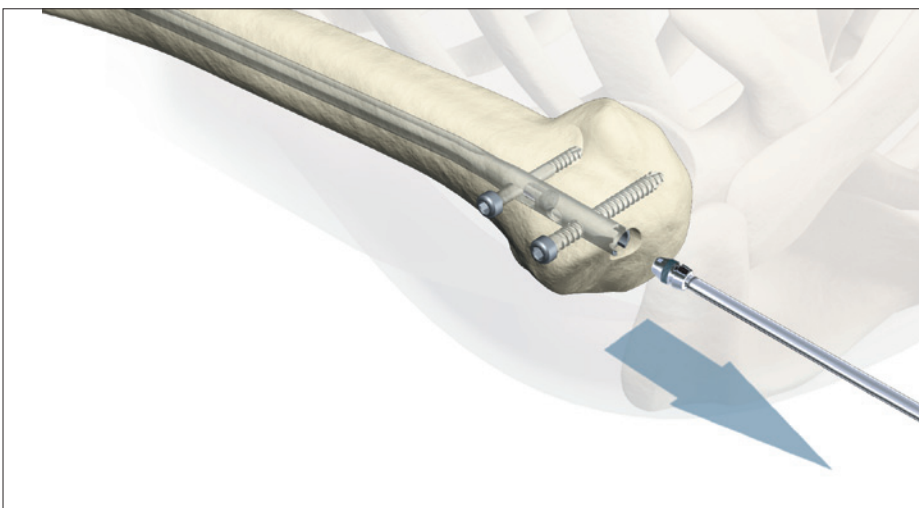

**Fig. 42**

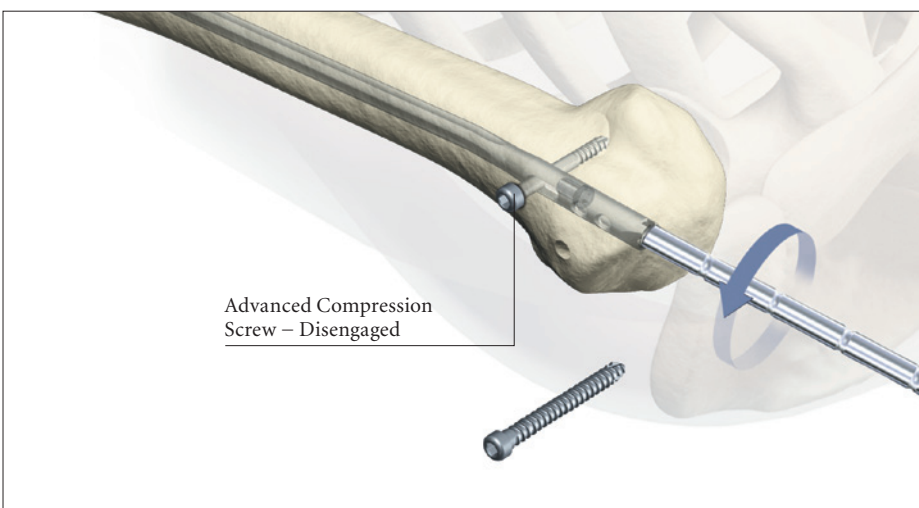

**Fig. 43**

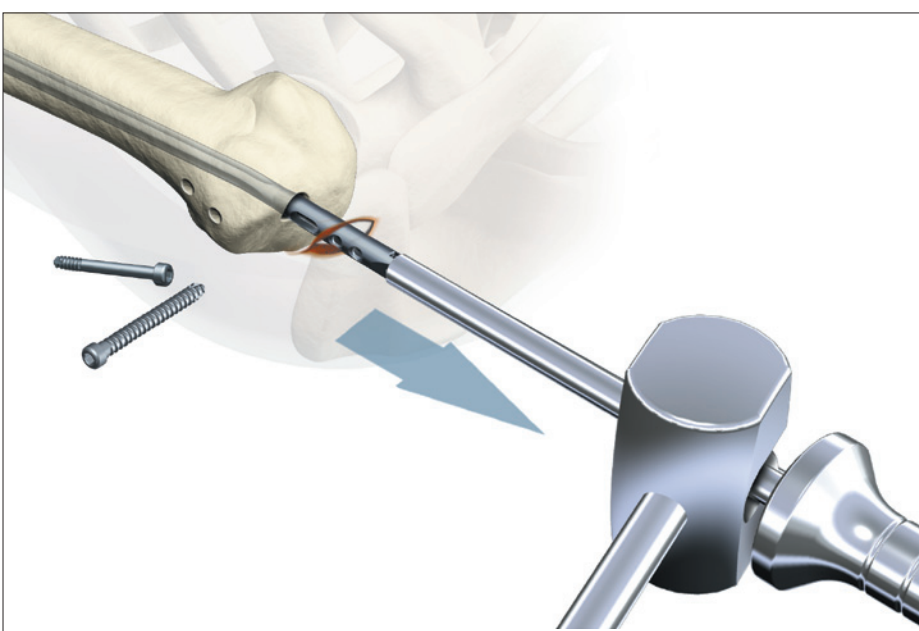

**Fig. 44**

# Operative Technique – Retrograde Technique

## Patient Positioning

The patient is placed on a radiolucent table in the prone position or lateral decubitus position. The affected arm is supported on an arm board or hand table. The shoulder is in 90° abduction, the elbow joint flexed also in a 90° position. In this position, fractures can be reduced in correct rotation.

Patient positioning should be checked to ensure that imaging of the entry site at the proximal humerus is possible. This allows the elbow to be hyper flexed to accommodate insertion of the implant parallel to the humerus.



## Incision

A posterior approach is used to access the distal humerus. Starting at the tip of the olecranon, a 6 cm incision is made in a proximal direction. The triceps tendon is split and muscle tissue is bluntly dissected and retracted until the upper edge of the olecranon fossa is displayed.

The distal insertion point for the nail is one centimeter above the olecranon fossa. The Insertion Site Template (703117) may be used to help determine the appropriate insertion site (Fig. 45). The medullary canal is opened using the Drill Ø3.5 × 130mm (1806-3550S) by drilling a set of linear holes (Fig. 46). The holes are then joined with the Self-guiding Rigid Reamer (703125) (Fig. 47).

### Note:

The drill guide slots of the retrograde Insertion Site Template (703117), must be centered and parallel to the medullary canal (long axis of the humerus).

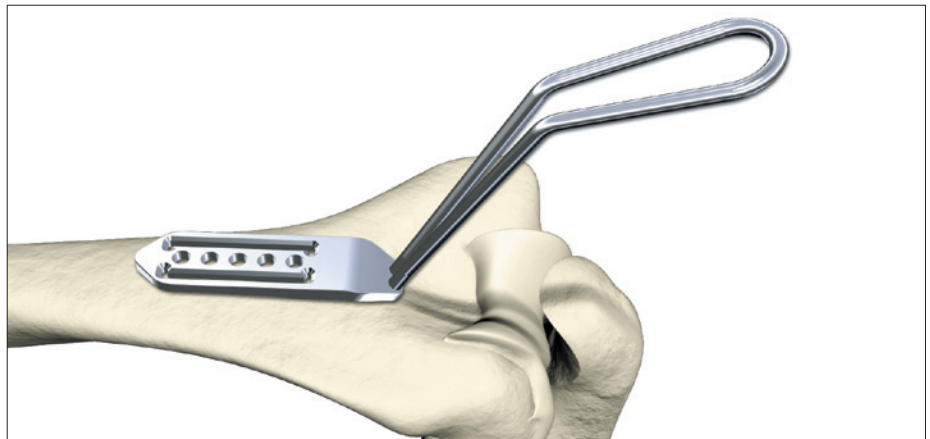

Fig. 45



Fig. 46

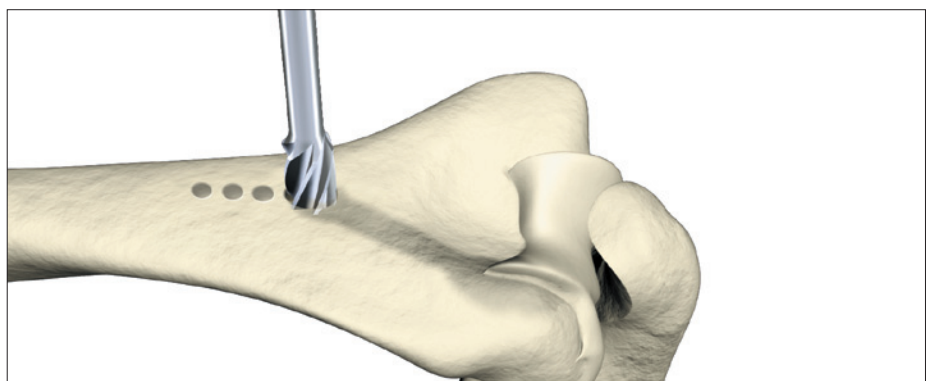

Fig. 47

# Operative Technique – Retrograde Technique

## Entry Point

Final insertion site preparation is performed with the Conical Rigid Reamer (703126) to create a longitudinal oval cortical hole at least 3cm in length and 1cm in width (Fig. 49).

The cortical bone is removed distally to the level of the olecranon fossa with the rigid reamers or small rongeur.

### Caution:

**Although the tip of the nail has a 4 degree bend that facilitates distal nail insertion, high compressive forces during nail insertion can result in fractures of the distal humerus if the insertion opening is too short or too steep.**

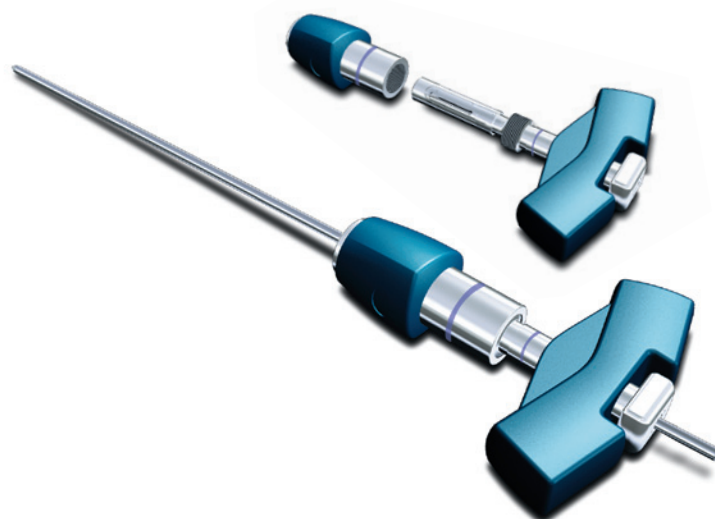

Fig. 48

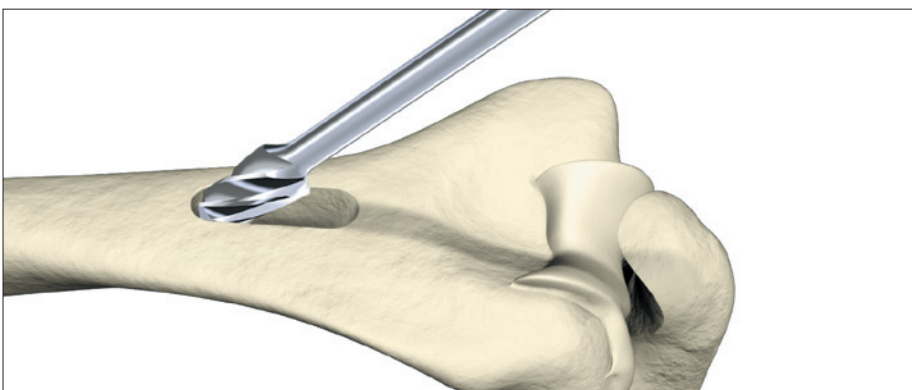

Fig. 49

## Unreamed Technique

The T2 Humeral Nail is cannulated, and may be introduced in an un-reamed fashion over a Smooth Tip Guide Wire. This simplifies fracture reduction and reduces the risk of iatrogenic distal fractures caused by trying to reduce the fracture with the nail.

The 2.2×800mm Smooth Tip Guide Wire (1806-0093S) is inserted under image control through the distal fragment and into the desired position within the proximal humerus using the Guide Wire Handle and Chuck (1806-1095 and 1806-1096) (Fig. 48 and 50).

The Reduction Rod (1806-0363) may be used as a fracture reduction tool to facilitate Guide Wire insertion (Fig. 51). The Guide Wire is advanced until the tip rests at the center of the humeral head. The Guide Wire should lie in the center of the metaphysis in both the A/P and Lateral views to help avoid offset positioning of the nail. The Guide Wire Handle is removed leaving the Guide Wire in place.

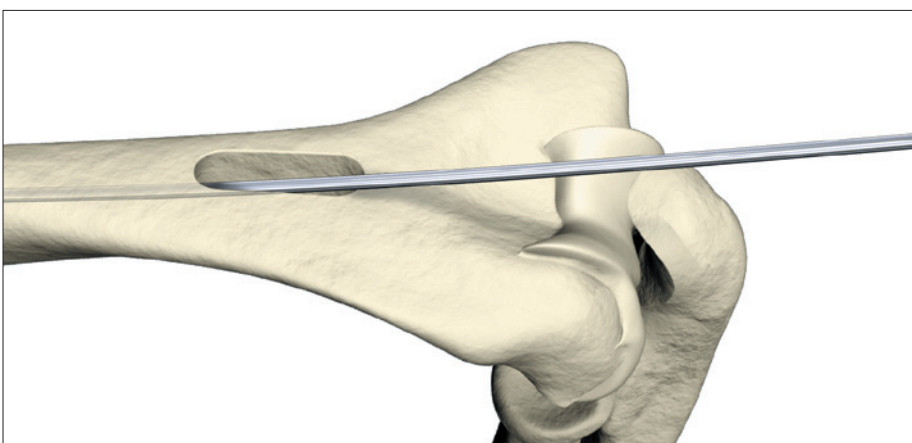

Fig. 50

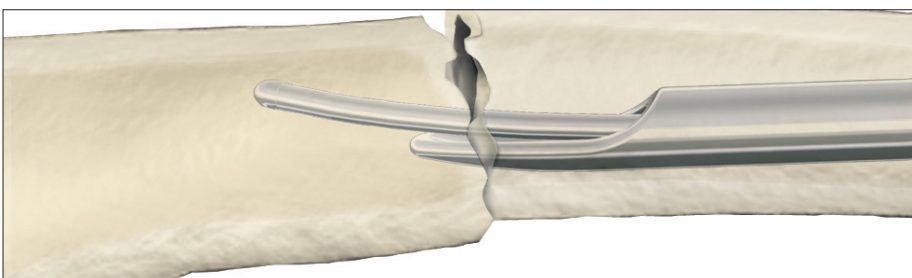

Fig. 51

# Operative Technique – Retrograde Technique

## Reamed Technique

For reamed techniques, the 2.5×800mm Ball Tip Guide Wire (1806-0083S) is inserted through the fracture site. The Reduction Rod or the Universal Rod, Short with the “optional” Reduction Spoon may be used as a fracture reduction tool to facilitate Guide Wire insertion across the fracture site (see Fig. 51).

Reaming is commenced in 0.5mm increments until cortical contact is appreciated. (Fig. 50). The final reamer should be 1mm–1.5mm larger than the diameter of the nail to be used.

The Guide Wire Pusher can be used to help keep the Guide Wire in position during reamer shaft extraction. The metal cavity at the end of the handle pushed on the end of the power tool facilitates to hold the Guide Wire in place when starting to pull the power tool. When close to the Guide Wire end place the Guide Wire Pusher with its funnel tip to the end of the power tool cannulation. While removing the power tool the Guide Wire Pusher will keep the Guide Wire in place (Fig. 53 and 54).

**Note:**

**The driving end of the 7mm nail is always 8mm.**

When reaming is complete, the Teflon Tube (1806-0073S) should be used to exchange the Ball Tip Guide Wire with the Smooth Tip Guide Wire for nail insertion.

**Note:**

**Do not insert any T2 Humeral Nail over any Ball Tip Guide Wire.**

An unreamed technique can be considered in cases, where the medullary canal has the appropriate diameter. In these cases, the nail can be introduced over the 2.2×800mm Smooth Tip Guide Wire (1806-0093S).

**Note:**

**X-Ray Templates should be used pre-operatively to determine the canal size radiographically.**

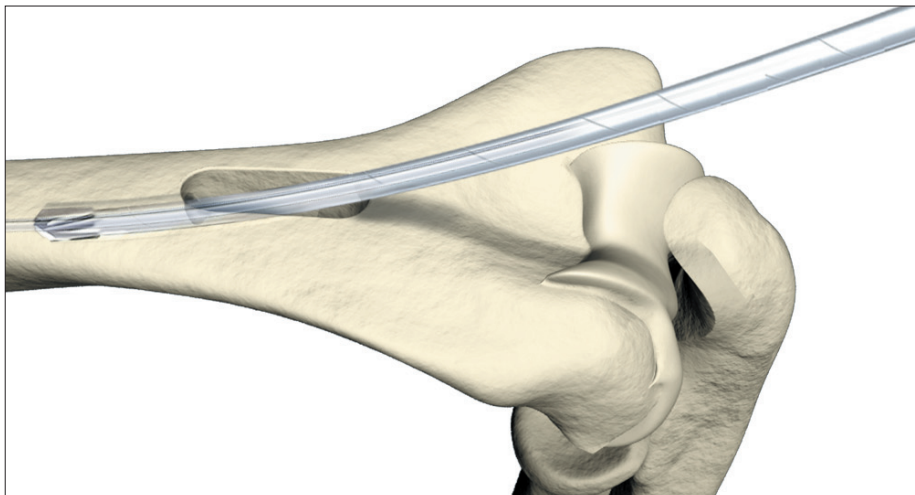

**Fig. 52**

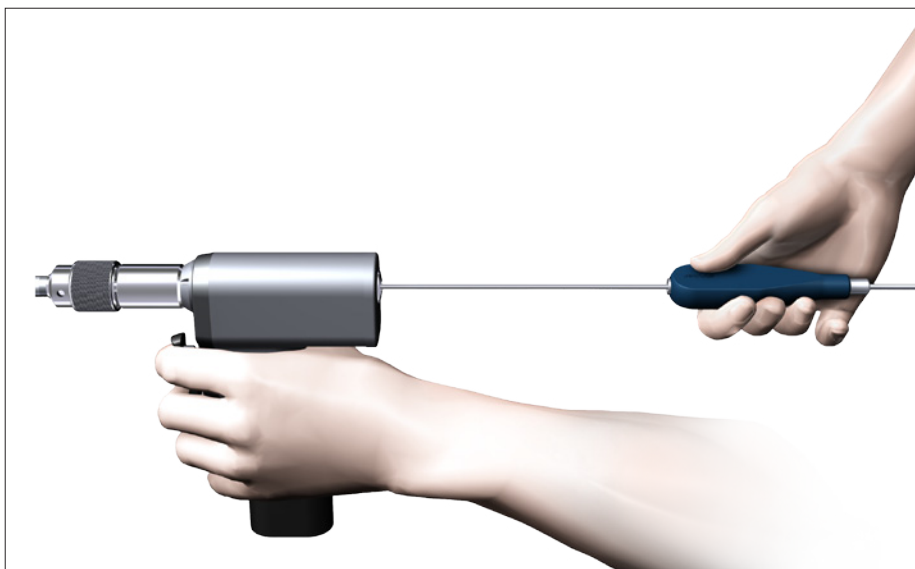

**Fig. 53**

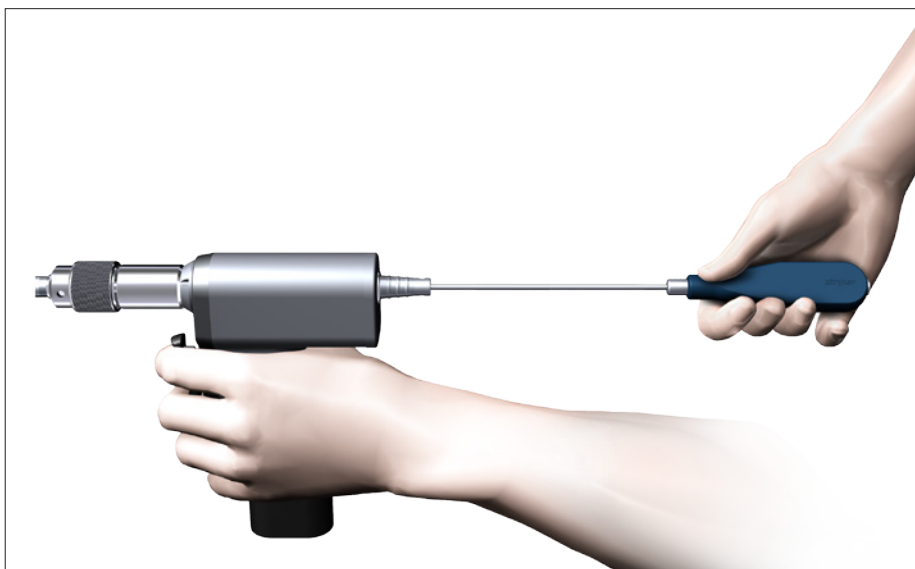

**Fig. 54**

# Operative Technique – Retrograde Technique

## Nail Selection

The X-Ray Template (1806-003) should be used preoperatively to determine canal size radiographically. This information may be utilized in conjunction with the clinical assessment of canal size as determined by the size of the last reamer used.

### Diameter

The diameter of the selected nail should be 1mm smaller than the last reamer used.

### Length

Nail length may be determined with the X-Ray Ruler (1806-0013) (Fig. 55). The Guide Wire Ruler (1806-0022) may be used by placing it on the Guide Wire and then reading the correct nail length at the end of the Guide Wire on the Guide Wire Ruler (Fig. 56). Confirm the position of the tip of the Guide Wire prior to measurement.

### Note:

**If the fracture is suitable for apposition/compression, the implant selected should be 6–10mm shorter than measured to help avoid migration of the nail beyond the insertion site.**



Fig. 55

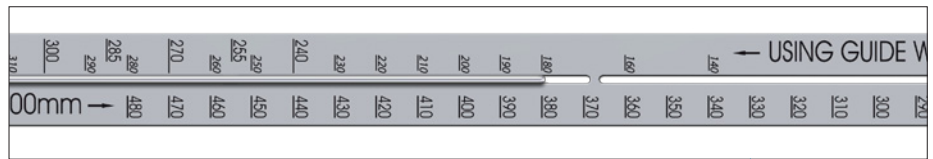

Fig. 56



The Guide Wire Ruler can be easily folded and unfolded.

## Nail Insertion

The selected nail is assembled onto the Target Device (1806-0143) with the Nail Holding Screw (1806-0163). Tighten the Nail Holding Screw with the Insertion Wrench (1806-0135) securely so that it does not loosen during nail insertion (Fig. 57).



Fig. 57

# Operative Technique – Retrograde Technique

**Note:**

Prior to nail insertion please check correct alignment by inserting a drill bit through the assembled Tissue Protection and Drill Sleeve placed in the required holes of the targeting device.

Upon completion of reaming and Guide Wire exchange, the appropriate size nail is ready for insertion and is advanced through the entry point past the fracture site to the appropriate level.

Gentle rotation of the nail may be necessary to start nail insertion. The nail should be advanced with manual pressure (Fig. 58). Aggressive use of the slotted hammer can result in additional fractures. If the nail does not advance easily, a check with image intensification should be made to see if the nail angle is too steep and the nail is impinging on the anterior cortex. In this case, it may be necessary to further widen the insertion opening.

**Note:**

A chamfer is located on the driving end of the nail to denote the end under X-Ray. Three circumferential grooves are located on the insertion post at 2mm, 6mm, and 10mm from the driving end of the nail (Fig. 59). Depth of insertion may be visualized with the aid of fluoroscopy.

The 3×285mm K-Wire may be inserted through the Target Device which identifies the junction of the nail and insertion post.

Insertion of the nail into the fracture zone should be monitored under image intensification.

The nail can be inserted over the Smooth Tip Guide Wire by gentle impaction on the Nail Holding Screw/ Insertion Wrench assembly (Fig. 60) or the Nail Holding Screw/Strike Plate assembly (Fig. 61).

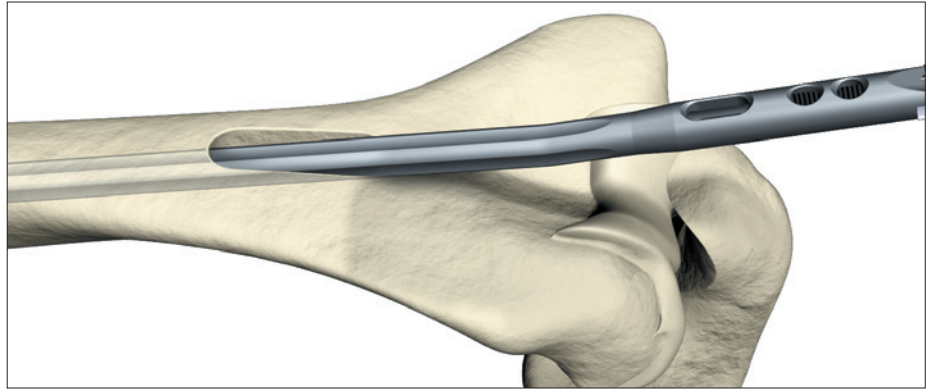

**Fig. 58**

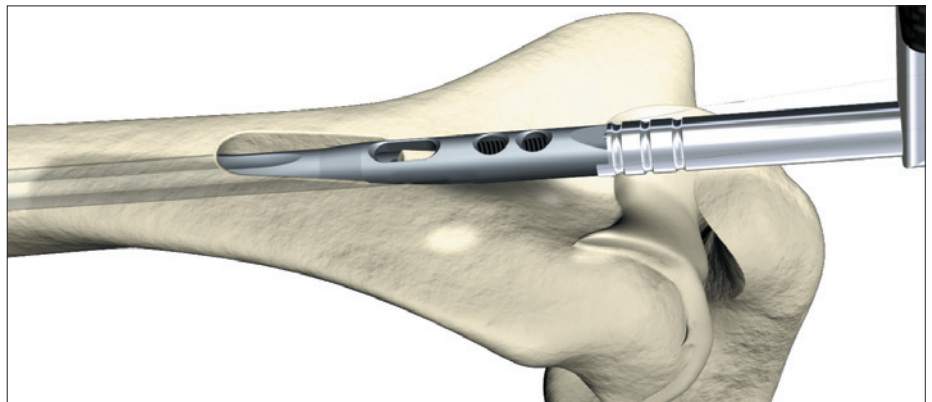

**Fig. 59**



**Fig. 60**

# Operative Technique – Retrograde Technique

In the case that the nail has been unintentionally inserted too deeply, repositioning may be carried out either by hand or by attaching the Universal Rod, Short to the Nail Holding Screw. The slotted hammer may be used to reposition the nail smoothly (Fig. 62). DO NOT hit on the Target Device.

When locking the retrograde nail in the Static Mode, the nail is countersunk a minimum of 6mm below the surface. When the implant is inserted in the Dynamic Mode, with active apposition/compression, or in the Advanced Locking Mode, the recommended insertion depth is 10mm.

**Note:**

**Remove the Guide Wire prior to drilling and inserting the Locking Screws.**

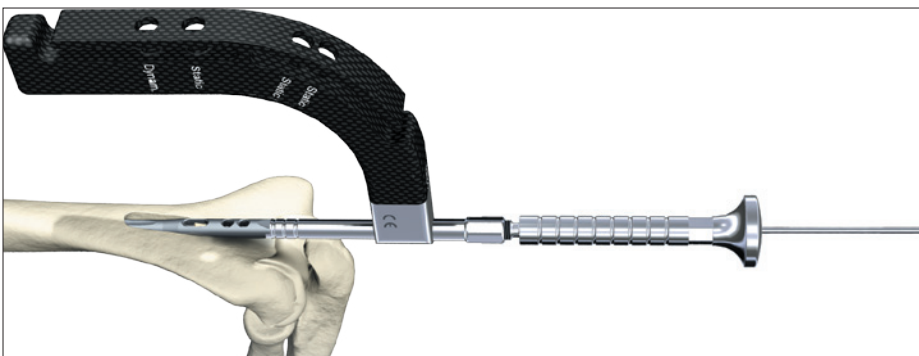

**Fig. 61**

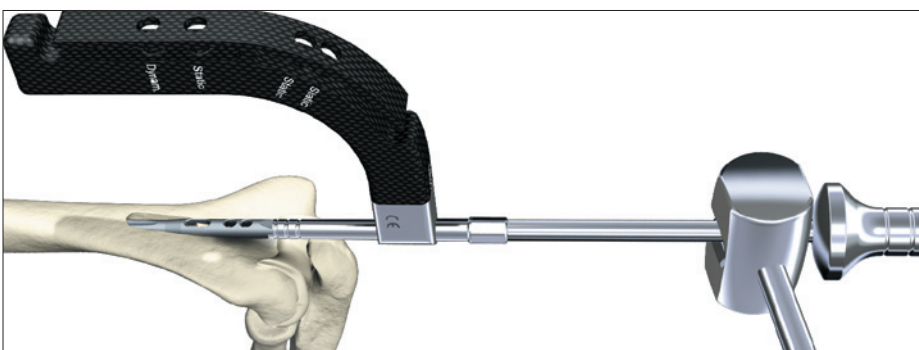

**Fig. 62**

# Operative Technique – Retrograde Technique

## Guided Locking Mode (via Target Device)

Prior to guided locking via the Target Device, the Nail Holding Screw must be firmly tightened using the Insertion Wrench, to ensure that the nail is in correct alignment with the Target Device.

The Target Device is designed to provide four options for guided locking (Fig. 63.1–63.4).

In Static Oblique Locking Mode, the two static holes closest to the end of the nail may be used for static oblique (30°) locking (Fig. 63.1).

- 1. Static**
- 2. Static**

In Static Transverse Locking Mode, the next static hole and the dynamic hole are used for static transverse locking (Fig. 63.2).

- 3. Static**
- 4. Dynamic**

In controlled Dynamic Mode, and/or controlled Apposition/Compression Mode, the dynamic hole is required (Fig. 63.3).

- 4. Dynamic**

In Advanced Locking Mode, the dynamic hole is required. After utilizing compression with the Advanced Compression Screw, the static hole is used (Fig. 63.4).

- 4. Dynamic**
- 3. Static**

The Tissue Protection Sleeve, Short (1806-0180) together with the Drill Sleeve, Short (1806-0210) and the Trocar, Short (1806-0310) are inserted into the Target Device by pressing the safety clip (Fig. 64). The friction lock mechanism is designed to keep the sleeve in place and prevent it from falling out. It is designed to also keep the sleeve from sliding during screw measurement. To release the Tissue Protection Sleeve, the safety clip must be pressed again (Fig. 65).

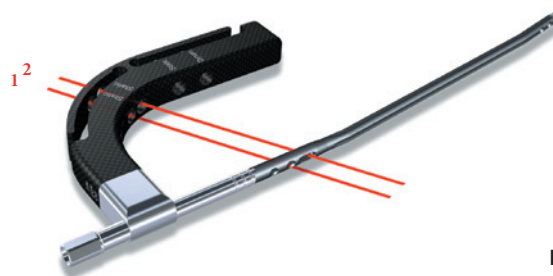

Fig. 63.1

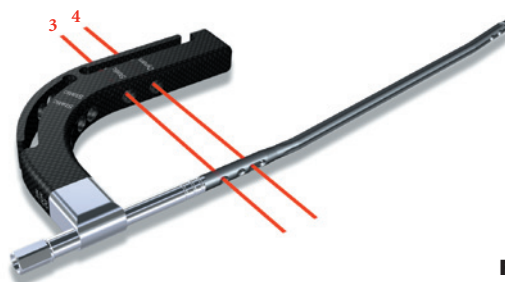

Fig. 63.2

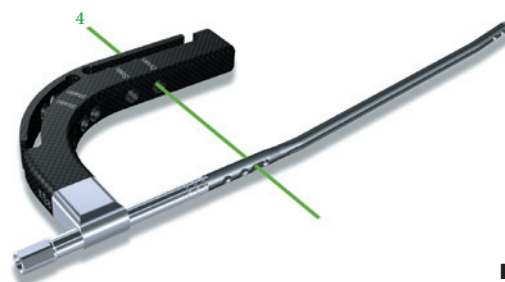

Fig. 63.3

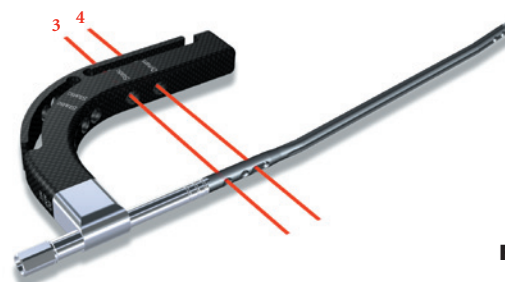

Fig. 63.4

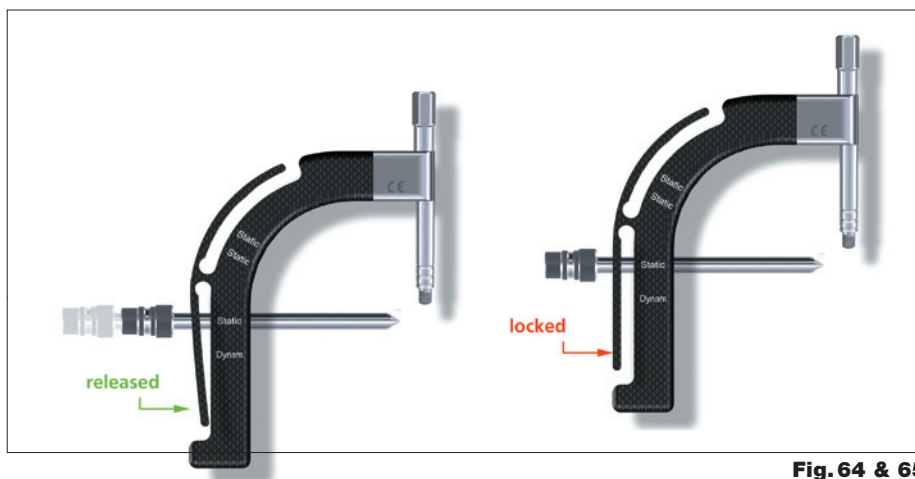

Fig. 64 & 65



# Operative Technique – Retrograde Technique

## Static Locking Mode

### Static Transverse Locking Mode

In unstable or comminuted fractures, the nail should be used as a standard interlocking nail. Static locking will help maintain the length of the nail and the rotational stability of the fracture.

The Short Tissue Protection Sleeve together with the Short Drill Sleeve and the Short Trocar are positioned through the static locking hole on the Target Device. A small skin incision is made and the assembly is pushed through, until it is in contact with the posterior cortex of the humerus.

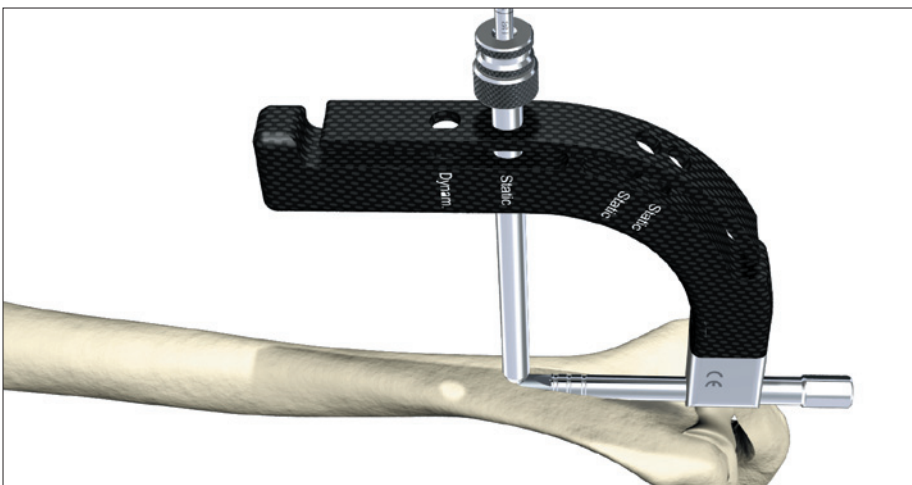

Fig. 66

### Note:

**Especially in the proximal humerus, use image intensification to help ensure the Tissue Protection sleeve is flush with the cortex or you could lose 1–2mm of screw measurement accuracy.**

The Trocar is removed, while the Tissue Protection Sleeve and the Drill Sleeve remain in position.

For accurate drilling and easy determination of screw length, use the center-tipped  $\text{Ø}3.5 \times 230\text{mm}$  calibrated Drill (1806-3540S). The Drill is forwarded through the Drill Sleeve and pushed onto the cortex.

### Caution:

**Make sure the Tissue Protection Sleeve/Drill Sleeve Assembly is seated on bone prior to selecting final screw length.**

After drilling both cortices, the screw length may be read directly off of the calibrated Drill at the end of the Drill Sleeve (Fig. 66 and 67).

### Note:

**The position of the end of the Drill as it relates to the far cortex is equal to where the end of the screw will be. Therefore, if the end of the Drill is 3mm beyond the far cortex, the end of the screw will also be 3mm beyond.**

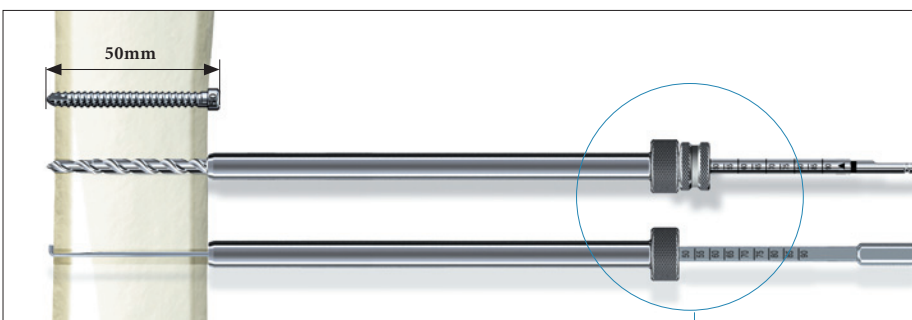

Fig. 67



# Operative Technique – Retrograde Technique

## Note:

The Screw Gauge, Short, is calibrated so that with the bend at the end pulled back flush with the far cortex, the screw tip will end 3mm beyond the far cortex (Fig. 67)

When the Drill Sleeve is removed, the correct 4mm Locking Screw is inserted through the Tissue Protection Sleeve using the Short Screwdriver Shaft (1806-0222) with the Teardrop Handle (702429). The screw is driven through both cortices and is near its proper seating position when the center of the groove around the shaft of the screwdriver is approaching the end of the Tissue Protection Sleeve (Fig. 68).

Use image intensification to confirm screw position through the nail as well as screw length. Repeat the locking procedure for the other statically positioned Locking Screw (Fig. 69).

## Caution:

The coupling of Elastosil handles contains a mechanism with one or multiple ball bearings. In case of applied axial stress on the Elastosil handle, those components are pressed into the surrounding cylinder resulting in a complete blockage of the device and possible bending.

To avoid intra-operative complications and secure long-term functionality, we mandate that Elastosil handles be used only for their intended use. DO NOT HIT any Elastosil handles.

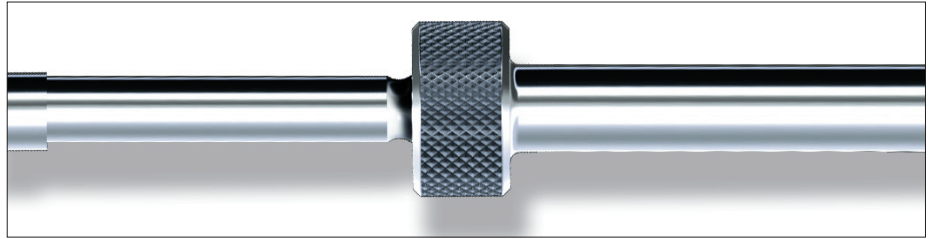

Fig. 68

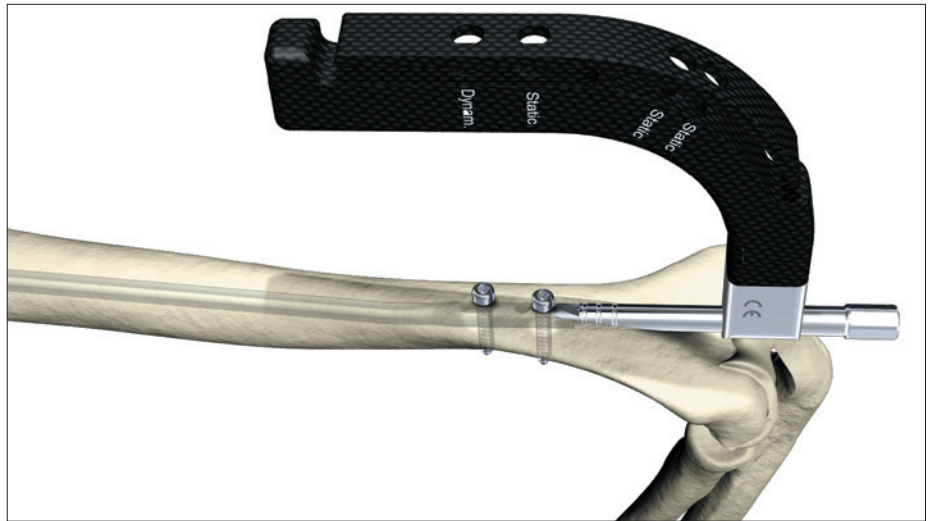

Fig. 69

# Operative Technique – Retrograde Technique

## Static Oblique Locking Mode

For the Static Oblique Locking Mode, place the assembly of Tissue Protection Sleeve together with the Drill Sleeve and the Trocar through the Static hole closest to the driving end of the nail. Refer to the procedure described for Locking Screw insertion (Fig. 70).

The second Fully Threaded Locking Screw is inserted through the Static hole next to the first hole and placed in an oblique manner through the oblong hole of the nail (Fig.71).

Confirm screw position and length with image intensification.

## Washer

If the nail insertion opening is too long, or if osteoporotic bone is encountered, it may not be possible to achieve bicortical purchase for the most distal Fully Threaded Locking Screw. A Washer, either Rectangular or Round, may be used to bridge the bone gap and allow for enhanced purchase of the Locking Screw (Fig. 72).

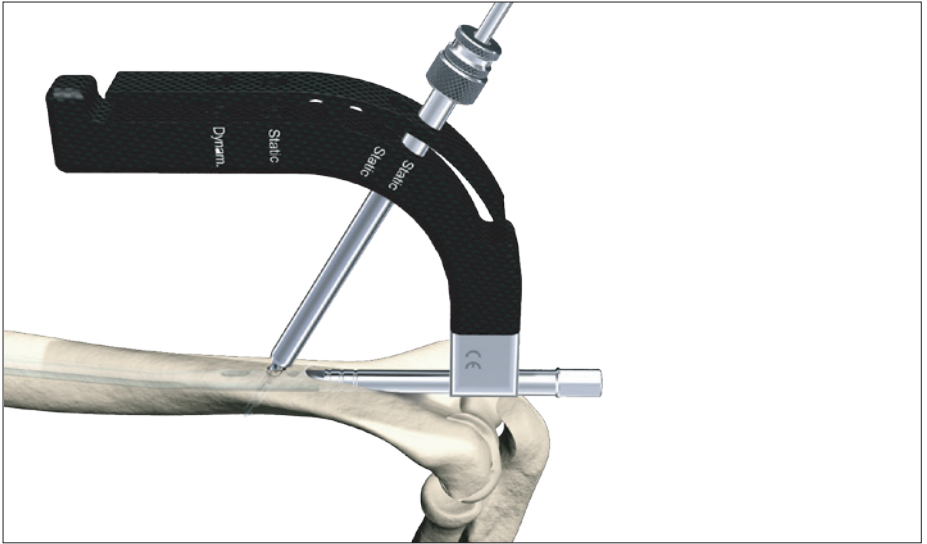

Fig. 70

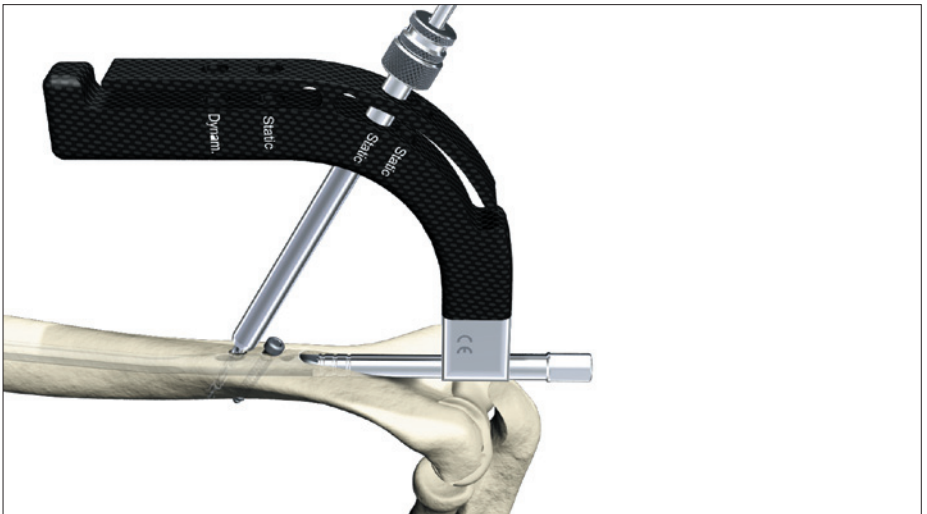

Fig. 71

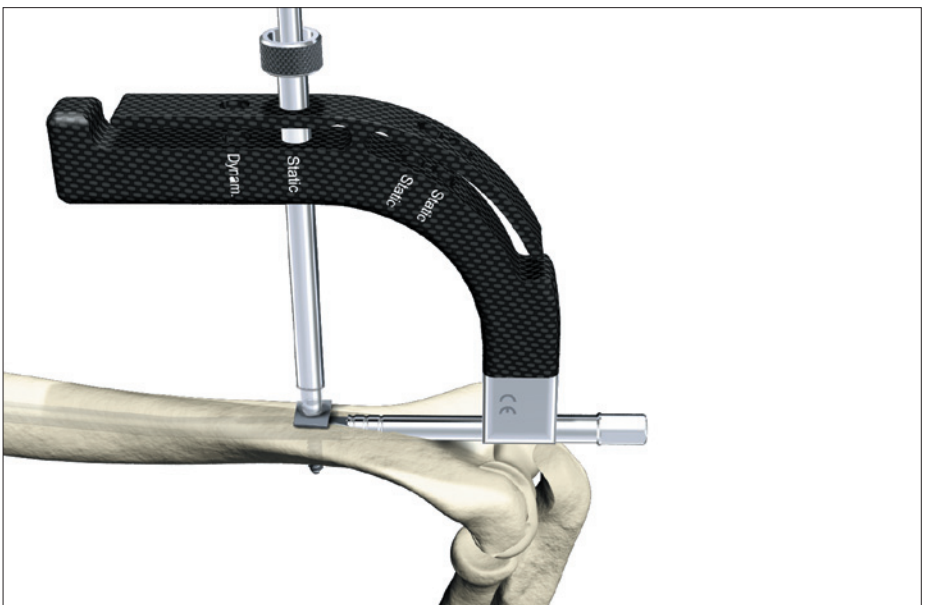

Fig. 72

# Operative Technique – Retrograde Technique

## Freehand Proximal Locking

The freehand technique is used to insert Locking Screws into both the A/P and M/L holes in the nail. Rotational alignment must be checked prior to locking the nail statically.

Multiple locking techniques and radio-lucent drill devices are available for freehand locking. The critical step with any freehand locking technique, proximal or distal, is to visualize a perfectly round locking hole with the C-Arm.

The center-tipped  $\text{Ø}3.5 \times 230\text{mm}$  Drill (1806-3540S), or the optional  $\text{Ø}3.5 \times 130\text{mm}$  Drill (1806-3550S), is held at an oblique angle to the center of the locking hole (Fig. 73). Upon X-Ray verification, the Drill is placed perpendicular to the nail and drilled through the anterior cortex. Confirm these views in both the A/P and M/L planes by X-Ray.

After drilling both cortices, the screw length may be read directly off of the Screw Scale, Short (1806-0360) at the orange color coded ring on the center-tipped Drill (Fig. 74). As with distal locking (Fig. 67, p.24), the position of the end of the drill is equal to the end of the screw as they relate to the far cortex.

Routine Locking Screw insertion is employed with the assembled Short Screwdriver Shaft and the Teardrop Handle.

If possible, the proximal humerus should be locked with two Fully Threaded Locking Screws (Fig. 75).

### Note:

**Use image intensification to confirm screw position within the nail as well as screw length.**

Alternatively, the Screw Gauge can be used to measure the screw length.

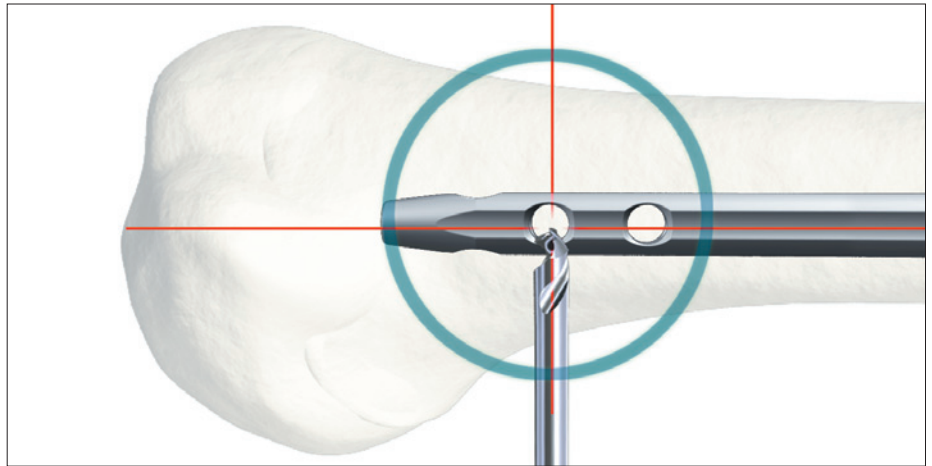

Fig. 73

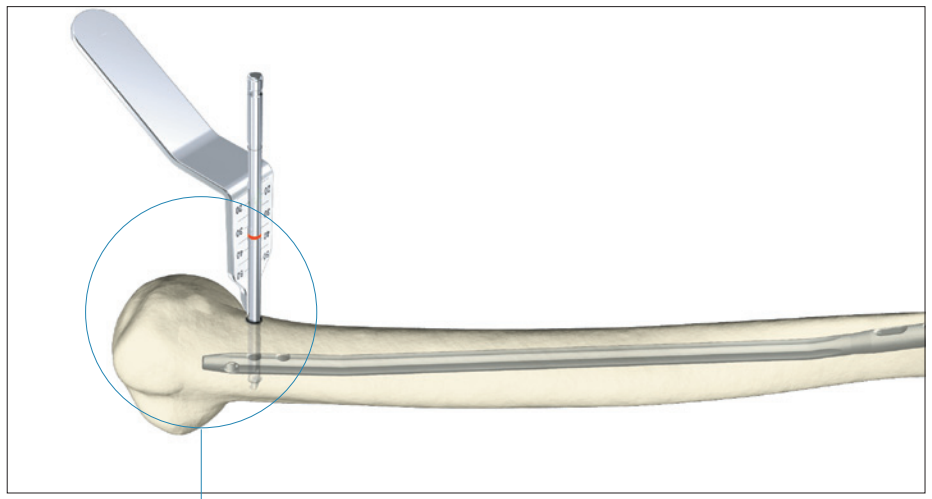

Fig. 74

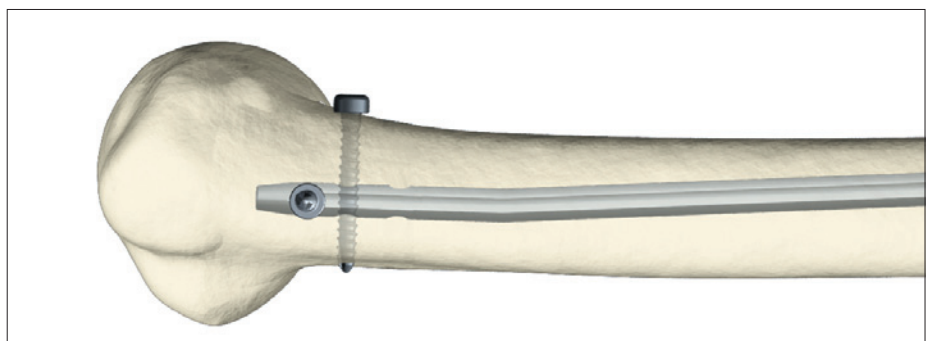
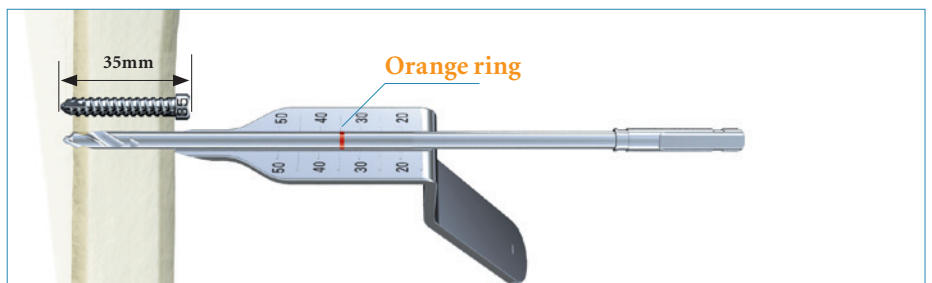

Fig. 75

# Operative Technique – Retrograde Technique

## End Cap Insertion

After removal of the Target Device, an End Cap is used to reduce the potential for bony ingrowth into the proximal threads of the nail.

End Caps are available in six sizes (Fig. 76).

The End Cap is inserted with the Short Screwdriver Shaft assembled on the Teardrop Handle after intra-operative radiographs show satisfactory reduction and hardware implantation (Fig. 77). Fully seat the End Cap to minimize the potential for loosening.

### Caution:

**To avoid impingement, carefully select the length of the End Cap.**

Close the wound using standard technique.



Fig. 76

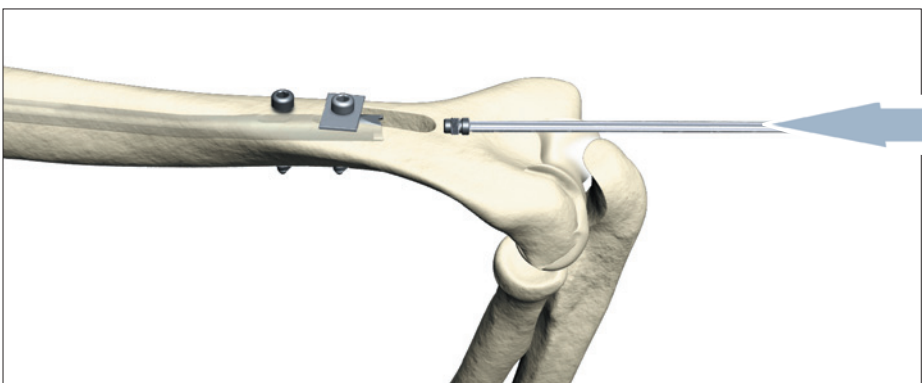

Fig. 77

## Dynamic Locking Mode

Controlled dynamic locking may be utilized for transverse or axially stable fractures.

Retrograde dynamization is performed by statically locking the nail proximally.

The guided Locking Screw is then placed in the dynamic position of the oblong hole. This allows the nail to move, and the fracture to settle while torsional stability is maintained (Fig. 78).

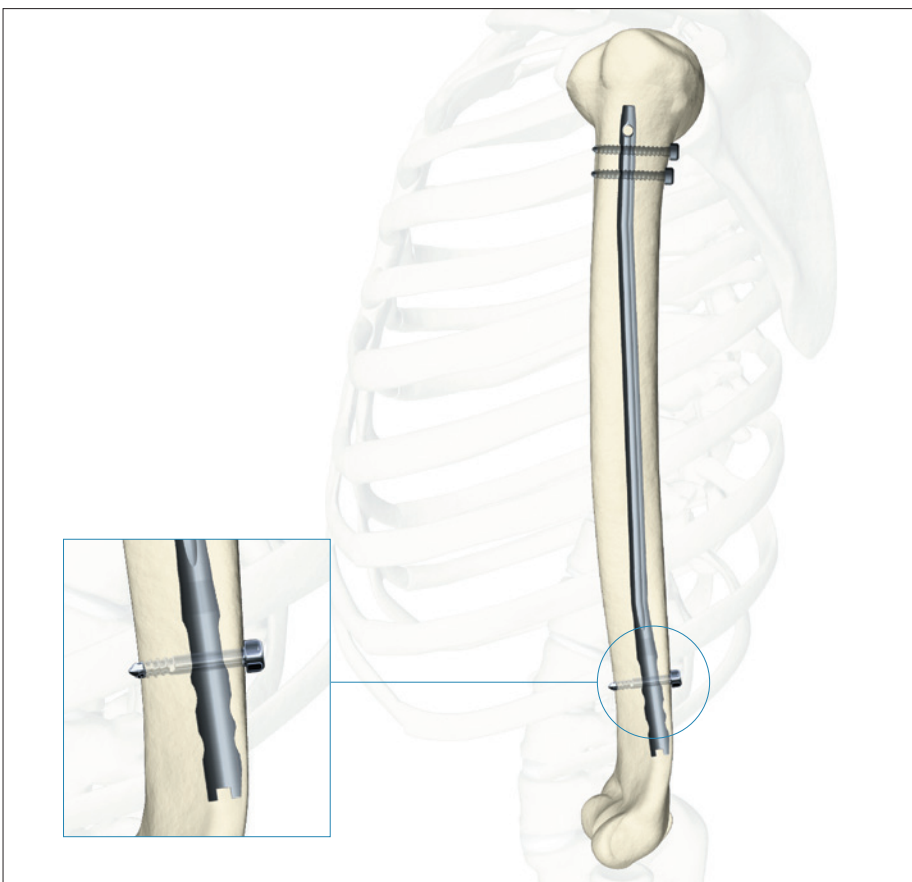

Fig. 78

# Operative Technique – Retrograde Technique

## Apposition/Compression Locking Mode

The retrograde T2 Humeral Nail provides the option to treat a humerus fracture with active mechanical apposition/compression prior to leaving the operating room.

**Note:**

**Proximal freehand static locking must be performed prior to applying active, controlled apposition/compression to the fracture site.**

If active apposition/compression is required, a Partially Threaded Locking Screw (Shaft Screw) is inserted via the Target Device in the dynamic position of the oblong hole. This will allow for a maximum of 6mm of active, controlled apposition/compression. In order to insert the Partially Threaded Locking Screw (Shaft Screw), drill both cortices with the  $\text{Ø}3.5 \times 230\text{mm}$  Drill (1806-3540S). Next, the near cortex ONLY is overdrilled with the  $\text{Ø}4.0 \times 180\text{mm}$  Drill (1806-4000S).

**Note:**

- After the opposite cortex is drilled with the  $\text{Ø}3.5 \times 230\text{mm}$  Drill, the correct screw length can be read directly off of the calibrated Drill at the end of the Drill Sleeve.
- It may be easier to “insert” the Compression Screw prior to fully seating the nail. Once the nail tip has cleared the fracture site, the Guide Wire (if used) is withdrawn. With the proximal portion of the nail not fully seated and extending out of the bone, the Advanced Compression Screw is inserted.
- Care should be taken that the shaft of the Compression Screw does not extend into the area of the oblong hole.

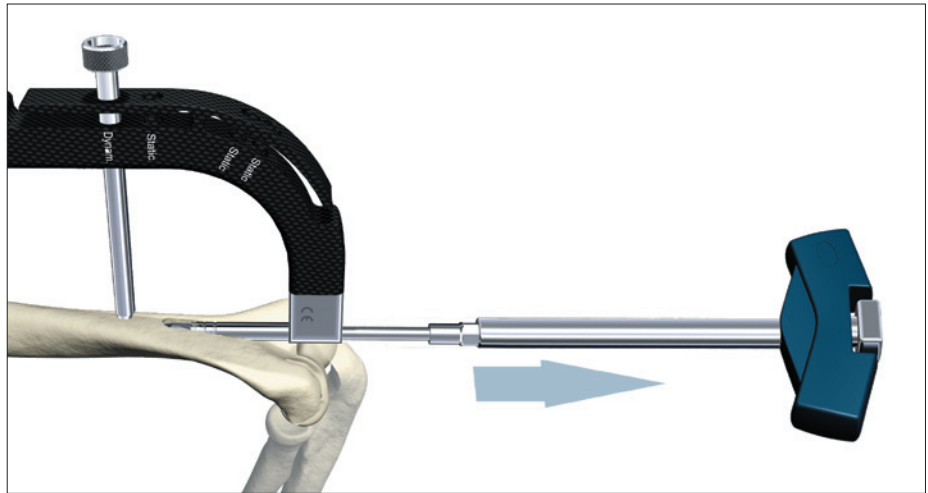

**Fig. 79**

# Operative Technique – Retrograde Technique

After the Partially Threaded Locking Screw (Shaft Screw) is inserted, the Nail Holding Screw is removed, leaving the insertion post intact with the nail (Fig. 79). This will act as a guide for the Compression Screw. The Compression Screw is inserted with the Compression Screwdriver Shaft (1806-0263) assembled on the Teardrop Handle through the insertion post (Fig. 80).

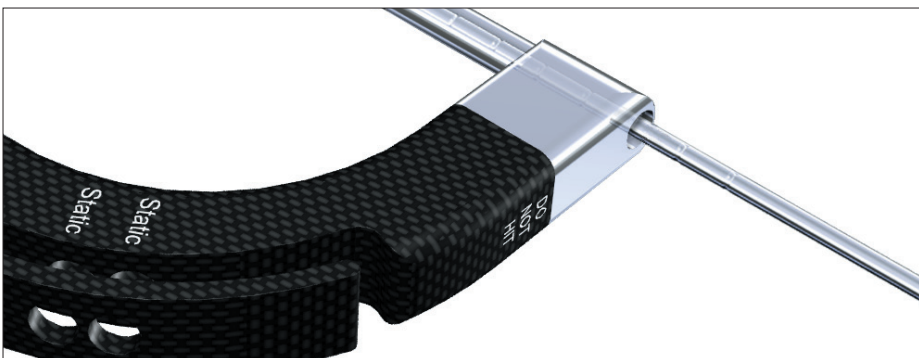

Fig. 80

The Short Tissue Protection Sleeve is removed and the Compression Screw is gently tightened utilizing the two-finger technique (Fig. 81). As the Compression Screw is advanced against the 4.0mm Partially Threaded Locking Screw (Shaft Screw), it draws the proximal fracture segment towards the fracture site, employing active apposition/compression. Image intensification will enable the surgeon to visualize active apposition/compression. Some bending of the transverse Partially Threaded Locking Screw (Shaft Screw) may be seen.

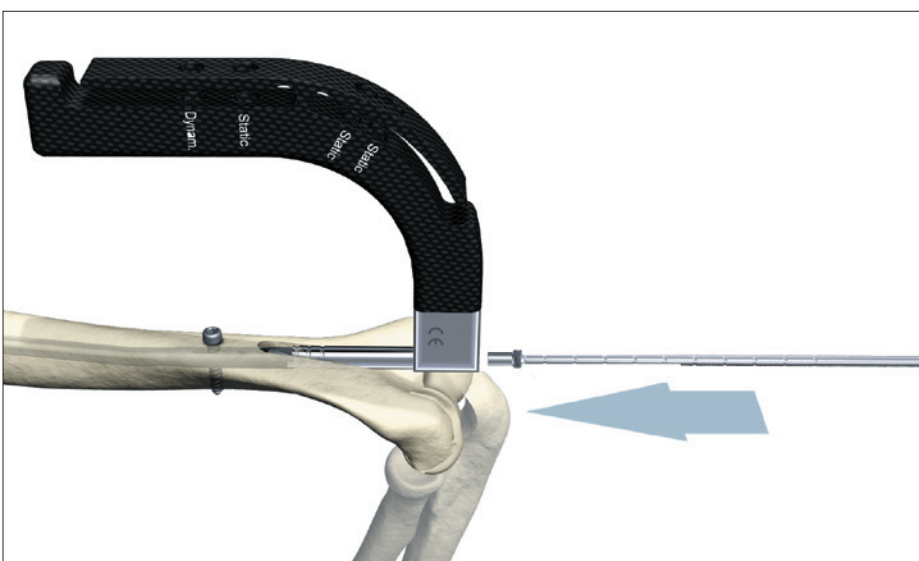

Fig. 81

## Note:

- **Apposition/compression must be carried out under X-Ray control. Over-compression may cause the nail or the Partially Threaded Locking Screw (Shaft Screw) to fail.**
- **When compressing the nail, the implant must be inserted in a safe distance from the entry point to accommodate for the 6mm of active compression. The three grooves on the insertion post are designed to help attain accurate insertion depth of the implant.**

# Operative Technique – Retrograde Technique

## Advanced Locking Mode

In order to achieve additional fixation and to reduce the load on the Partially Threaded Locking Screw (Shaft Screw), the design of the T2 Humeral Nail provides the opportunity to insert an additional Fully Threaded Locking Screw in the other transverse hole at the driving end of the nail after apposition/compression is utilized.

Prior to guided locking via the Target Device, the Nail Holding Screw must be tightened using the Insertion Wrench.

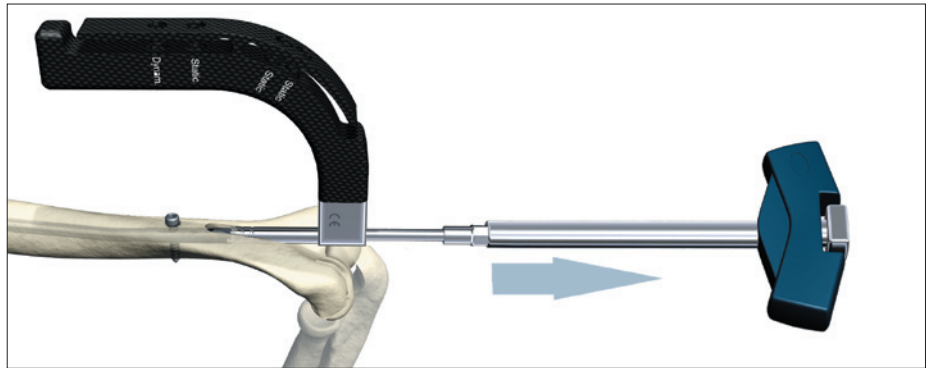

Fig. 82

The Compression Screw is inserted with the Compression Screwdriver Shaft. Fix the Compression Screw on the Compression Screwdriver Shaft. Remove the Nail Holding Screw leaving the Target Device in place (Fig. 82). Advance the Compression Screw through the Target Device until the desired amount of compression is achieved (Fig. 83). Visualize depth of insertion with the aid of fluoroscopy.

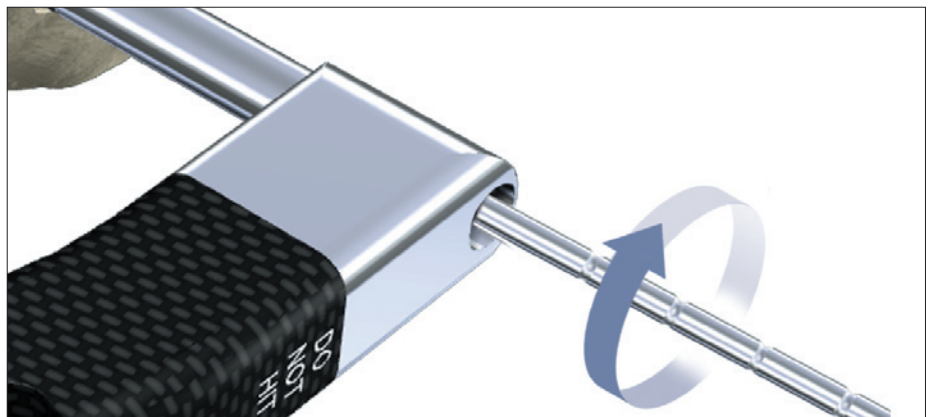

Fig. 83

### Note:

**As previously described, it may be easier to insert the Compression Screw prior to fully seating the nail.**

To reattach the Target Device to the nail, detach the Compression Screw Driver and screw the Nail Holding Screw into its required position. To reattach the Target Device to the nail, detach the Teardrop Handle from the Compression Screwdriver Shaft and screw the Nail Holding Screw over the Compression Screwdriver Shaft into its required position.

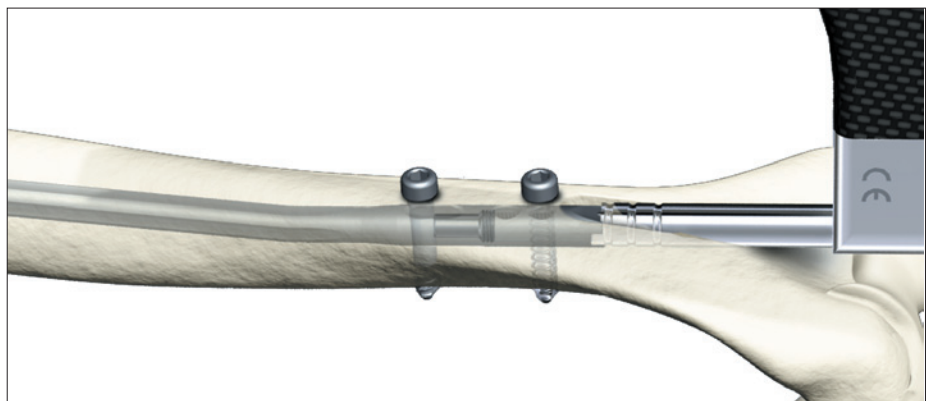

Fig. 84

To insert the second transverse Fully Threaded Locking Screw, follow the locking procedure for static locking (Fig. 84 and 85).

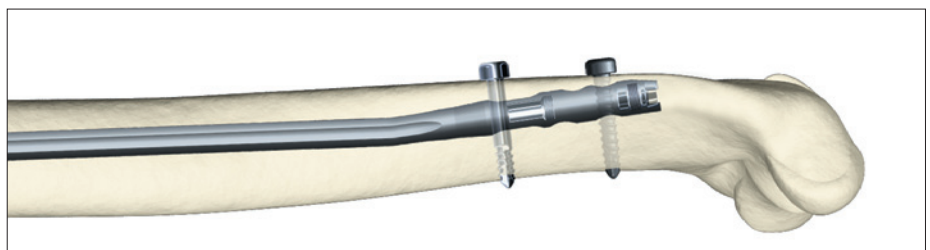

Fig. 85



# Operative Technique – Retrograde Technique

## Nail Removal

Nail removal is mostly an elective procedure. If they were used, the End Cap and Compression Screw are removed with the Short Screwdriver Shaft and the Teardrop Handle. If Advanced Locking Mode was utilized, the most distal screw is extracted first, thus allowing access to the compression screw.

The Universal Rod, Short is inserted into the driving end of the nail before all Locking Screws are removed with the Short Screwdriver Shaft and the Teardrop Handle (Fig. 86).

**Note:**

**Attaching the Universal Rod to the nail first, will reduce the potential for nail migration, then the Locking Screws may be removed safely.**

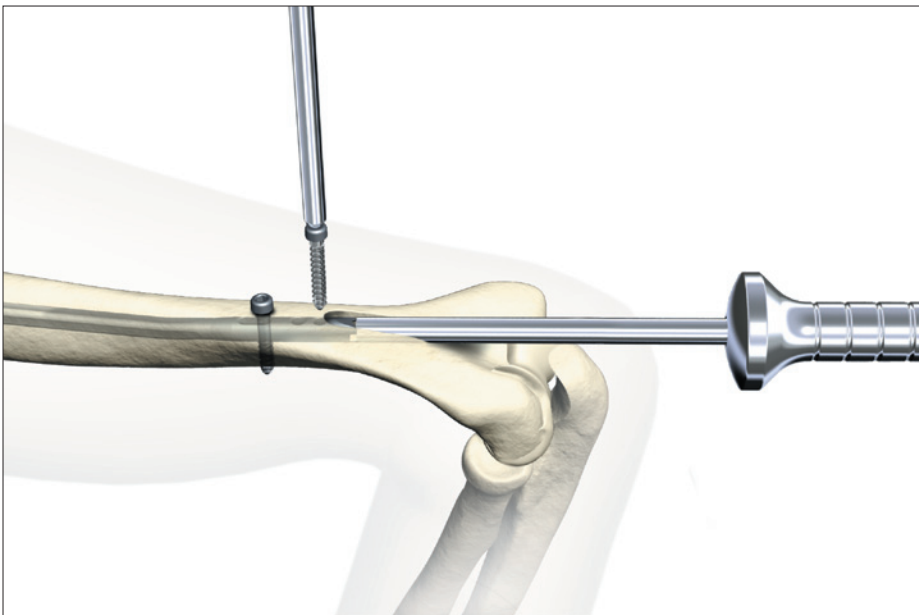

Fig. 86

The Slotted Hammer is used to extract the nail in a controlled manner (Fig. 87).

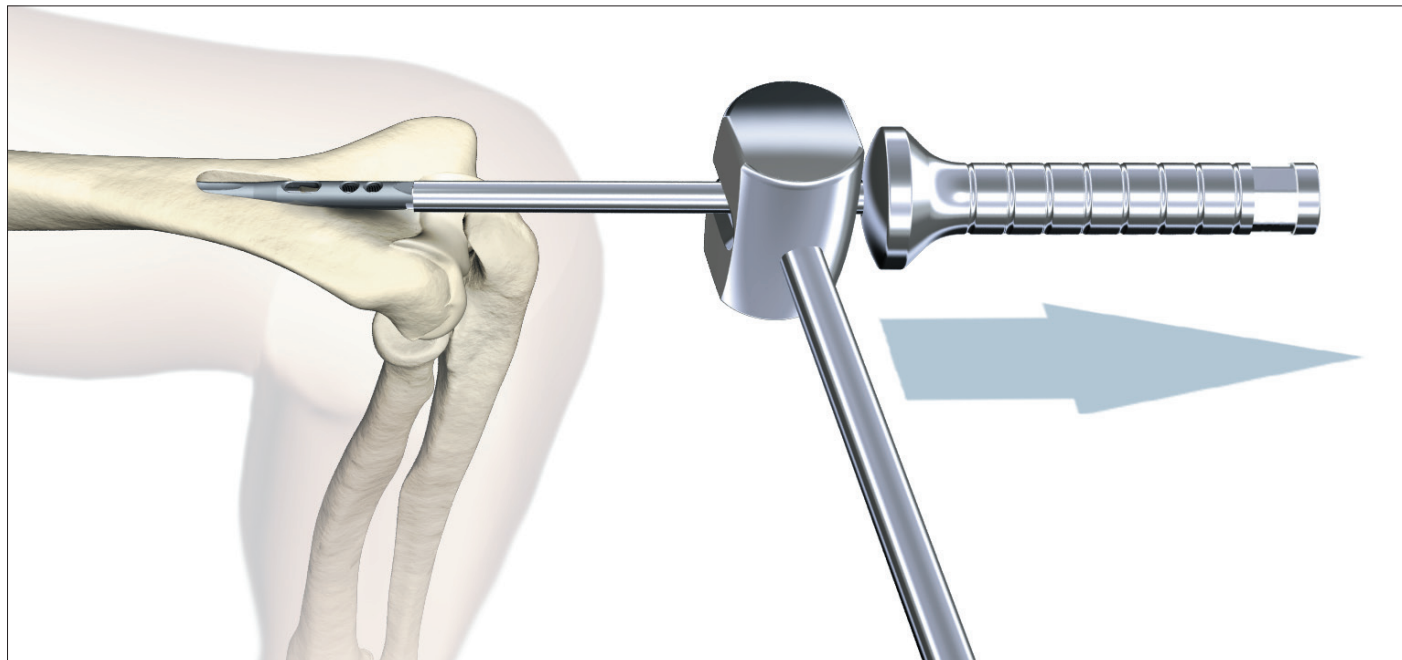

Fig. 87

# Notes

# Notes

## Reconstructive

---

Hips  
Knees  
Trauma & Extremities  
Joint Preservation  
Orthobiologics

## Medical & Surgical

---

Power Tools & Surgical Accessories  
Image Guided Navigation  
Endoscopy & Arthroscopy  
Integrated Communications  
Beds, Stretchers & EMS  
Sustainability Solutions

## Neurotechnology & Spine

---

Craniomaxillofacial  
Interventional Spine  
Neurosurgical, Spine & ENT  
Neurovascular  
Spinal Implants

**Manufactured by:**  
Stryker Trauma GmbH  
Prof.-Küntschers-Straße 1-5  
D-24232 Schönkirchen  
Germany

**Distributed by:**  
Stryker  
325 Corporate Drive  
Mahwah, NJ 07430  
t: 201 831 5000

[www.stryker.com](http://www.stryker.com)

This document is intended solely for the use of healthcare professionals. A surgeon must always rely on his or her own professional clinical judgment when deciding whether to use a particular product when treating a particular patient. Stryker does not dispense medical advice and recommends that surgeons be trained in the use of any particular product before using it in surgery. The information presented is intended to demonstrate a Stryker product. A surgeon must always refer to the package insert, product label and/or instructions for use, including the instructions for Cleaning and Sterilization (if applicable), before using any Stryker product. Products may not be available in all markets because product availability is subject to the regulatory and/or medical practices in individual markets. Please contact your Stryker representative if you have questions about the availability of Stryker products in your area.

Stryker Corporation or its divisions or other corporate affiliated entities own, use or have applied for the following trademarks or service marks: Stryker, T2. All other trademarks are trademarks of their respective owners or holders.

The products listed above are CE marked.

Literature Number global: **B1000006 Rev. 5**  
Content ID: T2-ST-6

Copyright © 2013 Stryker