



PERSONA

THE PERSONALIZED
KNEE SYSTEM

Surgical Technique



Introduction

Successful total knee arthroplasty depends in part on re-establishment of normal lower extremity alignment, proper implant design and orientation, secure implant fixation, and adequate soft tissue balancing and stability. *Persona*® The Personalized Knee System is designed to help the surgeon accomplish these goals by combining alignment accuracy with a simple, straight-forward technique.

The instruments and technique assist the surgeon in restoring the center of the hip, knee, and ankle to lie in a straight line, establishing a neutral mechanical axis. The femoral and tibial components are oriented perpendicular to this axis. Femoral rotation is determined using the posterior condyles, the epicondylar axis or Whiteside's line as a reference. The instruments enable accurate cuts to ensure robust component fixation.

A wide variety of component sizes, shapes and constraint options allow for optimized component fit and soft tissue balancing. The femur, tibia, and patella are prepared independently, and can be cut in any sequence using the principle of measured resection (removing enough bone to allow replacement by the prosthesis). Adjustment cuts may be needed later. The anterior referencing technique uses the anterior cortex to set the A/P position of the femoral component. The posterior condyle cut is variable.

Constraint Options

The degree of constraint of the articular surface can be planned based on surgeon preference and patient requirements. The use of the cruciate-retaining (CR) femoral provisionals and components can be used when the posterior cruciate ligament (PCL) is intact.

The CR femoral provisionals and components can be used when the PCL is sacrificed or deficient and removed, if used with the Ultracongruent (UC) articular surface provisionals and components.

Also, posterior stabilized (PS) femoral provisionals and components can be used with the PS or Constrained Posterior Stabilized (CPS) articular surfaces provisionals and components when the PCL is deficient and removed.

PS femoral components cannot be used with CR or UC articular surfaces and CR femoral components cannot be used with PS or CPS articular surfaces.

The CPS articular surfaces can be used to provide moderate varus/valgus constraint in patients to facilitate soft tissue balance and stability. The CPS articular surfaces shall be used with cemented non-porous femoral and tibial components only. Additional information for this product may be found in the Constrained Posterior Stabilized (CPS) Surgical Technique (97-5026-072-00).

The UC, PS and CPS implants can be used in the following situations, depending on the degree of the deformity, the stability of the ligaments and the quality of the bone. The surgeon is responsible for assessing whether a more constraining implant/system or revision implant/system is necessary.

1. Marked valgus deformity – requiring PCL and lateral soft tissue release.
2. Prior high tibial osteotomies – soft tissue balancing is the same as for a valgus deformity with lateral soft tissue and PCL release.
3. Patellectomy - PCL incomplete or absent.
4. Most revision situations – PCL deficient or nonfunctional

Note: The UC, PS and CPS components should not be used if the PCL is present.

Please refer to the package inserts for complete product information, including contraindications, warnings, precautions, and adverse effects.

Preoperative Planning

Obtain 36-inch or 53-inch standing anteroposterior and lateral radiographs of the extremity, as well as a sunrise view of the patella. The entire femur should be visualized to rule out any structural abnormalities, as the distal femoral cut will be referenced from an intramedullary rod in the medullary canal.

Use the template overlay (available through your Zimmer Representative) to determine the angle between the anatomic axis and the mechanical axis. This angle will be reproduced intraoperatively. This surgical technique helps the surgeon ensure that the distal femur will be cut perpendicular to the mechanical axis and, after soft tissue balancing, will be parallel to the resected surface of the proximal tibia.

Surgical Approach

The surgeon can choose a midvastus approach, a subvastus approach, or a parapatellar medial arthrotomy. Also, depending on surgeon preference, the patella can be either everted or subluxed. The femur, tibia, and patella are prepared independently, and can be cut in any sequence using the principle of measured resection (removing enough bone to allow replacement by the prosthesis).

Patient Preparation

To prepare the limb for total knee arthroplasty, adequate muscle relaxation is required. The anesthesiologist should adjust the medication based on the patient's habitus and weight, and administer to induce adequate muscle paralysis for a minimum of 30-40 minutes. It is imperative that the muscle relaxant be injected prior to inflation of the tourniquet. Alternatively, spinal or epidural anesthesia should produce adequate muscle relaxation. If desired, apply a proximal thigh tourniquet and inflate it with the knee in hyperflexion to maximize that portion of the quadriceps that is below the level of the tourniquet. Once the patient is draped and prepped on the operating table, determine the landmarks for the surgical incision.

Magnet Usage

Warning: Some instruments in the *Persona* System contain magnets. All *Persona* magnetic instruments should be kept at a safe distance from a patient's active implantable medical device(s) (i.e. pacemaker). These types of devices may be adversely affected by magnets. Instruments containing magnets should be kept on an appropriate table or stand when not in use at the surgical site.

Symbols

Symbols have been established for the following:

- Left
- Right
- Varus/Valgus
- Medial/Lateral
- Standard
- Do not implant – Not for implant
- Lock
- Unlock
- Anterior Referencing
- Do not impact
- Cemented
- Stemmed
- Inset Only

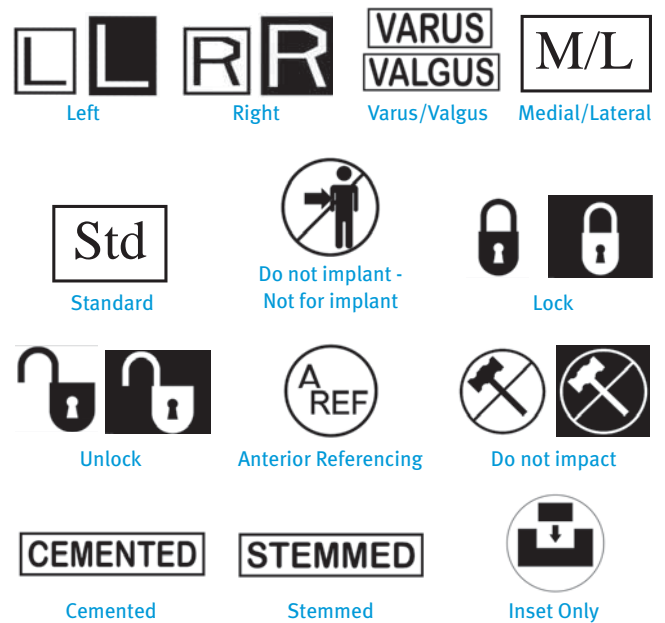

Screw Information

A new screw and driver is available with the introduction of the *Persona* System.

The screws are shipped sterile, two per package and are designed for single use.

Note: If this screw is used during the procedure for instrument fixation, it should be removed prior to closure as it is NOT implantable. Additionally, the 2.5mm Female Hex Screws and 2.5mm Male Hex Driver should not be used in cortical bone, as this may increase the incidence of stripping of the driver.



Persona® The Personalized Knee System Surgical Technique	Table of Contents	
	Resect Distal Femur	1
	Resect Proximal Tibia	7
	Size Femur and Establish External Rotation	15
	Complete Femoral A/P and Chamfer Resections	17
	Establish Size and Rotation of Tibia	19
	Drill and Broach Tibia	20
	Prepare the Patella	23
	CR Femoral Finishing and Trialing	26
	PS Femoral Finishing and PS Box Preparation	28
	Perform Trial Reduction	33
	Tibial Articular Surface Provisional (TASP) Assembly	34
	Implant Components	38
	Close Incision	42

Appendix A: Varus/Valgus Recut Guides	43
Appendix B: Spacer Block Technique	45
Appendix C: Optional Instruments	48
Appendix D: Compatibility Charts	58

Resect Distal Femur

Assemble Adjustable Distal Resection Instrumentation

- Pull the lever on the Modular Handle and insert the IM Rod (**Fig. 1**). Orientation of the IM Rod will align with the polished line on the sides of the Modular Handle.

TECHNIQUE TIP

1.A

Alternately, the IM Rod may be inserted into the top of the Modular Handle to accommodate surgical preference.

- Set the valgus angle on the Adjustable Valgus Guide by pressing the button and rotating the dial to the appropriate left or right valgus angle from 0° to 9° (**Fig. 2**).
- Avoid turning the Locking Knob excessively in the counterclockwise, or "unlocking", direction to prevent it from binding.
- Insert the IM Rod into the Adjustable Valgus Guide.

Note: If desired, align the depth markings on the IM Rod with the flat plate of the Adjustable Valgus Guide to set the IM Rod at a specific length. Inserting the IM Rod beyond the double line marking, indicated with caution symbols, may prevent assembly of the Modular Handle to the IM Rod (**Fig. 3**).

- Refer to Appendix C for Optional Instruments to resect the distal femur.

- Set the resection depth on the Adjustable Resection Tower by rotating the dial (**Fig. 4**). The '0' setting indicates a 10mm resection. Adjustments can be made in 1mm increments from 10mm to 14mm.



Fig. 1

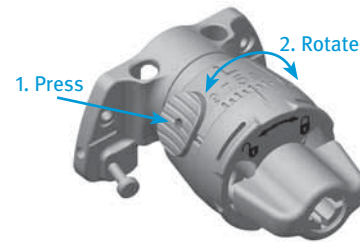

Fig. 2

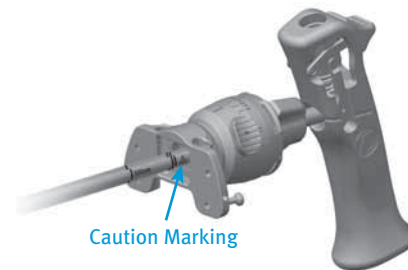

Fig. 3

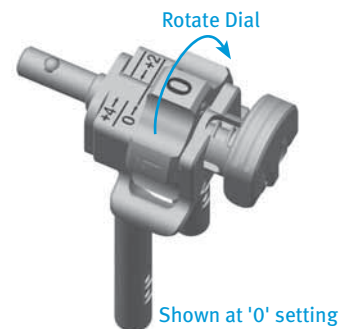

Fig. 4

Instruments



Persona
8mm IM Rod
42-5099-002-00



Persona
Modular Handle
42-5099-014-00



Persona Valgus
Alignment Guide
42-5099-004-00



Persona
Adjustable
Resection Tower
42-5099-008-00

Note: The '0' setting can be set to indicate a 1mm through 9mm resection depth, in 1mm increments, by assembling the corresponding Resection Plate to the Valgus Guide. **Figure 5** illustrates this with the 9mm Resection Plate. The 9mm and 8mm Resection Plates may facilitate correction of a flexion contracture and the 1mm-3mm Resection Plates can be used for recutting the distal femur, if needed.



Fig. 5

- Insert the Adjustable Resection Tower into the Adjustable Valgus Guide.
- Rotate the lock lever on the Adjustable Resection Tower to the unlocked, or “in-line”, position and fully insert into the Cut Guide (**Fig. 6a**).

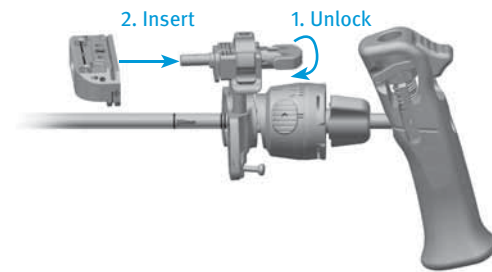

Fig. 6a

Flip the lock lever to the locked, or “vertical”, position to secure it to the Cut Guide (**Fig. 6b**).

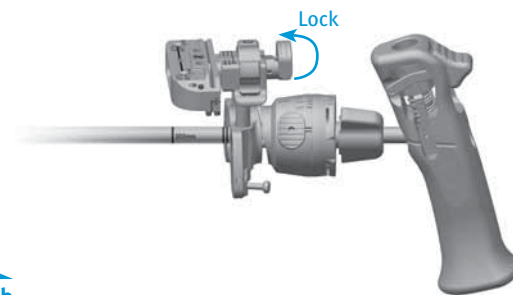

Fig. 6b

TECHNIQUE TIP

1.B

The Adjustable Resection Tower is compatible with the Fixed Valgus Guide and the Fixed Resection Tower is compatible with the Adjustable Valgus Guide. These instruments can be interchanged to accommodate surgical preference.

Instruments



Persona
8mm IM Rod
42-5099-002-00



Persona
Modular Handle
42-5099-014-00



Persona Valgus
Alignment Guide
42-5099-004-00



Persona
Adjustable
Resection Tower
42-5099-008-00



Persona 0°
Distal Cut Guide
42-5099-010-00



Persona
9mm Distal
Resection Plate
42-5099-015-09

Establish Femoral Alignment

- Drill the IM canal using the 8mm IM Step Drill (Fig. 7). Suction the canal to remove medullary contents.
- Insert the IM Rod and assembled distal resection instrumentation into the IM canal far enough to ensure the most accurate replication of the anatomic axis.

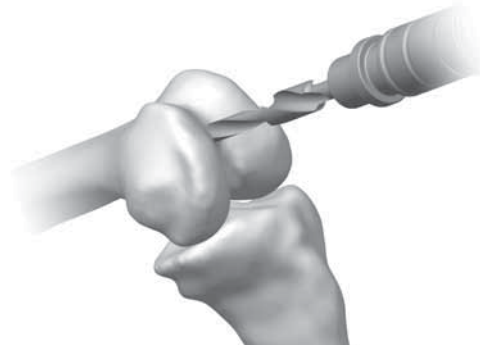

Fig. 7

- Set the orientation of the Adjustable Valgus Guide by placing it against the most prominent distal condyle and rotating it about the IM Rod so that the engraved lines are aligned with the epicondylar axis (Fig. 8a).
- Turn the lock knob on the Adjustable Valgus Guide clockwise, to the locked position, to secure orientation of the assembly (Fig. 8b).

Note: Setting rotation of the Adjustable Valgus Guide is important for creating a distal resection that matches the desired valgus angle selected. It does not set the rotation of the femoral component.

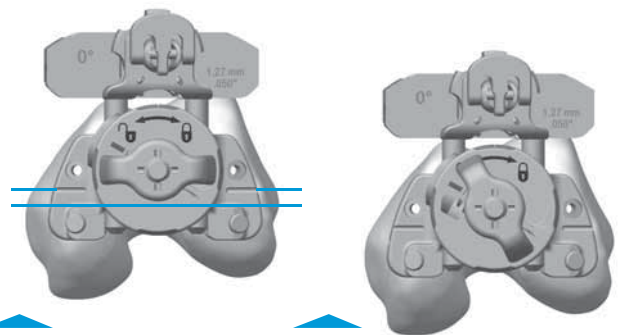

Fig. 8a

Fig. 8b

- For additional fixation, or in lieu of using the lock knob, impact the captured pin on the medial or lateral side of the Adjustable Valgus Guide until the head of the captured pin is flush with the plate (Fig. 9).

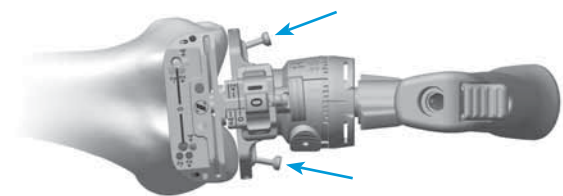

Fig. 9

Instruments



8mm IM
Step Drill
00-5978-014-00



Persona
8mm IM Rod
42-5099-002-00



Persona
Modular Handle
42-5099-014-00



Persona Valgus
Alignment Guide
42-5099-004-00



Persona
Adjustable
Resection Tower
42-5099-008-00



Persona 0°
Distal Cut Guide
42-5099-010-00

Resect Distal Femur

- Verify the Adjustable Valgus Guide is set to the proper side (left or right) and angle and that the Adjustable Resection Tower is set to the appropriate depth.

TECHNIQUE TIP

1.C

If unsure of the Adjustable Resection Tower depth setting, rotate the dial clockwise until a “click” is felt. This occurs when the dial moves from the ‘4’ setting to the ‘0’ setting. The bold ‘0’ will be visible on the dial and the line will be aligned with the ‘0’ mark along the shaft (Fig. 10).

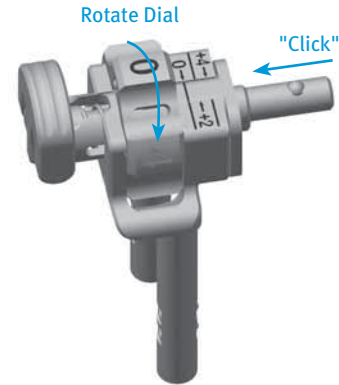

Fig. 10

TECHNIQUE TIP

1.D

Confirm valgus alignment by inserting the Drop Rod Adapter into the large holes on the anterior face of the Cut Guide and insert an Alignment Rod into the Drop Rod Adapter (Fig. 11).

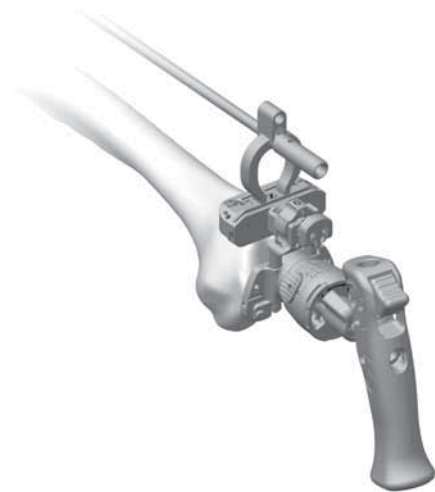
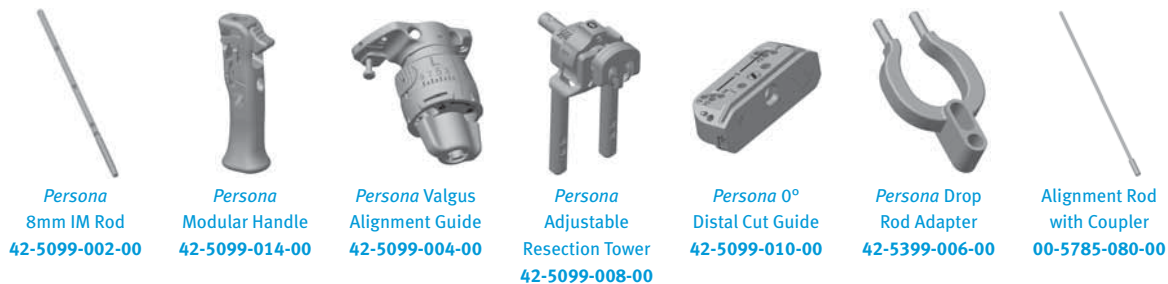

Fig. 11

Instruments



- Insert a Trocar Tipped Pin through each of the standard pin holes marked '0' on the anterior surface of the Cut Guide (Fig. 12).

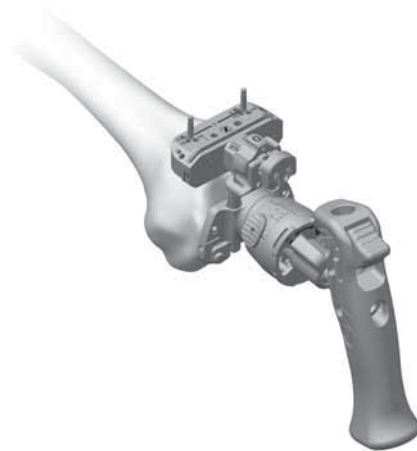

Fig. 12

- Flip the lock lever on the Adjustable Resection Tower to the unlocked, or “in-line”, position and pull the handle to remove the IM Rod and assembled distal resection instrumentation leaving only the Cut Guide attached to the femur (Fig. 13).

Note: If the captured pin was deployed it may be necessary to first remove it from the bone using the Pin Puller. Alternatively, removing the IM Rod from the Adjustable Valgus Guide may facilitate removal of the captured pin from the bone.

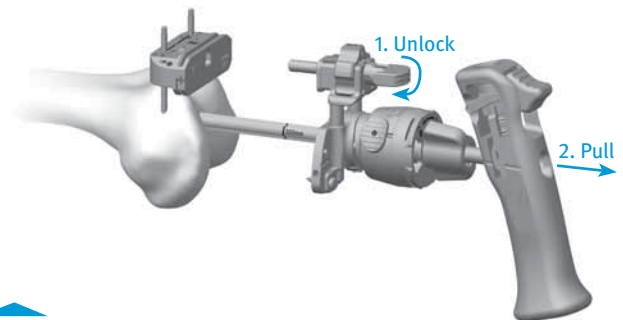

Fig. 13

Optional Instrument

A Fixed Distal Resection System exists for users who, for all patients, maintain a consistent valgus angle for their distal cut. For use of this instrument refer to Appendix C: Optional Instruments: Resect Distal Femur - Fixed Distal Resection Instrument Section 1.

TECHNIQUE TIP

1.E

Additional 2mm adjustments may be made by using the sets of holes marked -2, +2, and +4. These sets of holes indicate, in millimeters, the amount of additional bone resection each will yield relative to the resection setting on the Resection Tower (where '0' represents 10mm. However, if the 9mm Resection Plate is used, the '0' represents 9mm).

Instruments



Persona
8mm IM Rod
42-5099-002-00



Persona
Modular Handle
42-5099-014-00



Persona Valgus
Alignment Guide
42-5099-004-00



Persona
Adjustable
Resection Tower
42-5099-008-00



Persona 0°
Distal Cut Guide
42-5099-010-00



3.2mm x 75mm
Trocar Tipped Drill
Pin (2.5mm hex)
00-5901-020-00



Pin/Screw
Inserter
00-5901-021-00

- Insert the Resection Guide into the cut slot of the Cut Guide to verify the depth of resection.
- Insert a Trocar Tipped Pin through at least one of the locking, or oblique, pin holes in the Cut Guide to further secure the Cut Guide to the femur (Fig. 14).
- Using a 1.27mm (0.050-inch) oscillating saw blade through the cut slot in the Cut Guide, resect the distal femur.

Note: The flatness of the distal femoral resection is critical to ensuring adequate contact between the porous femoral implant and the bone. If using a porous femoral implant, evaluate the flatness of the resection prior to sizing and modify the cut as necessary so that it is completely flat.

- Remove all pins and the Cut Guide.

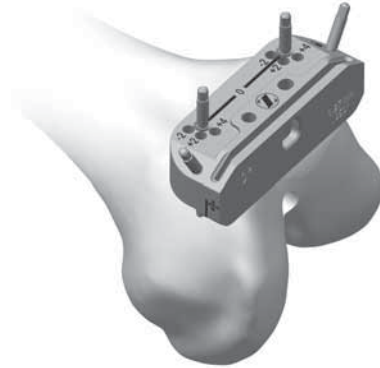

Fig. 14

Optional Cutting Technique

- If desired, the bone resection can be made from the top (most distal) surface of the Cut Guide (Fig. 15a). The top surface of the Cut Guide is 4mm from the cut slot. Therefore, if cutting from the top surface, the position of the Cut Guide must be adjusted by moving the Cut Guide from the Trocar Tipped Pins through the '0' holes and reinserting the Cut Guide onto the Trocar Tipped Pins through the holes marked '+4' (Fig. 15b). Insert a Trocar Tipped Pin through at least one of the locking, or oblique, pin holes in the Cut Guide to further secure the Cut Guide to the femur prior to cutting the femur.

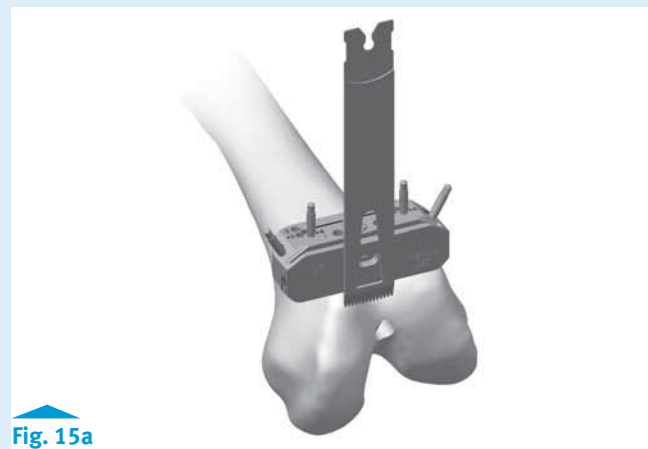

Fig. 15a

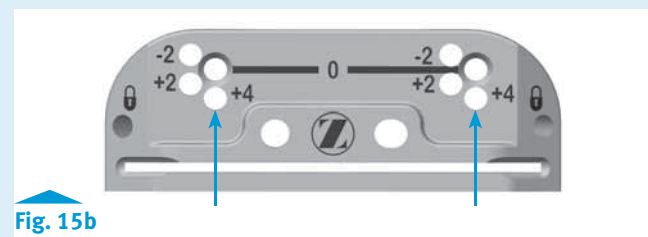

Fig. 15b

Instruments



Persona 0°
Distal Cut Guide
42-5099-010-00



3.2mm x 75mm
Trocar Tipped Drill
Pin (2.5mm hex)
00-5901-020-00



Pin/Screw
Insertor
00-5901-021-00



Resection Guide
00-5977-084-00



Multi Pin Puller
00-5901-022-00

Resect Proximal Tibia

Assemble Extramedullary (EM) Alignment Guide

- Depress and hold the button on the EM Distal Rod and insert the threaded rod on the EM Ankle Clamp into the distal rod and release the button. Depress and hold the button on the distal end of the EM Proximal Tube and insert the EM Distal Rod into the EM Proximal Tube and release the button (**Fig. 16**).

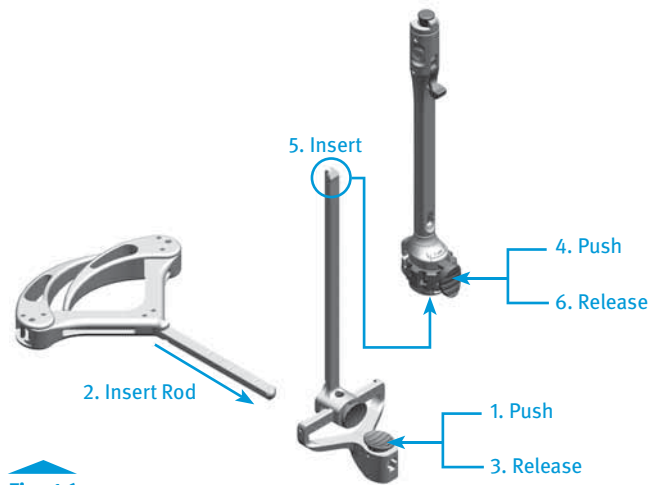

Fig. 16

- Attach the selected tibial cut guide to the EM Alignment Guide (**Fig. 17**).
 - Lift the lever on the EM Proximal Tube up.
 - Translate the cut guide onto the top of the EM Proximal Tube, under the locking cone.
 - Push down the lever on the EM Proximal Tube to lock the cut guide in place.

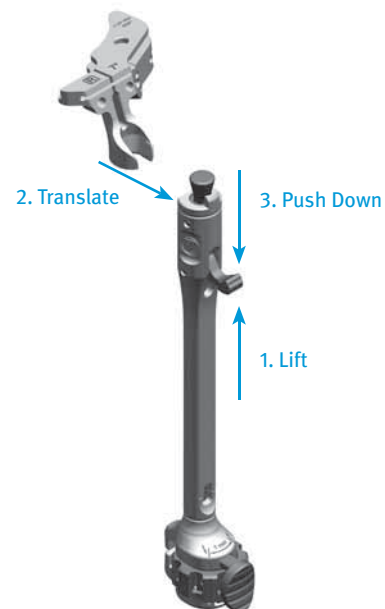

Fig. 17

Instruments



Persona EM
Proximal Tube
42-5399-001-00



Persona EM
Distal Rod
42-5399-002-00



Persona EM
Ankle Clamp
42-5399-003-00



Persona Tibial
Cut Guide
Left - 3°
42-5399-051-03



Persona Tibial
Cut Guide
Left - 7°
42-5399-051-07

- The buttons shown in **Figure 18** are used to adjust the following: varus/valgus angle of the cut guide, slope of the cut guide, the height of the cut guide. The height adjustment button can be depressed for macro-adjustment or the dial can be rotated for micro-adjustment.

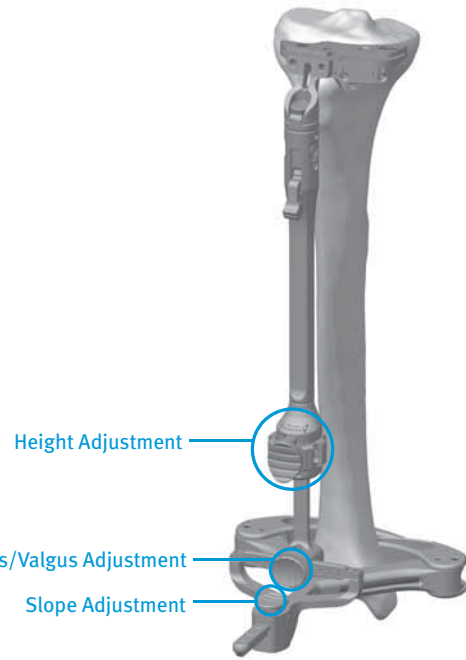

Fig. 18

One full rotation of the dial equals 4mm of height adjustment and 1/4 turn equals 1mm of height adjustment (**Fig. 19**). Rotating the height adjustment dial clockwise shortens the alignment guide and rotating the dial counterclockwise lengthens the alignment guide.

- The system includes six different cut guides: a 7-degree cut guide and a 3-degree guide, in left, right and universal (non-sided) configurations.

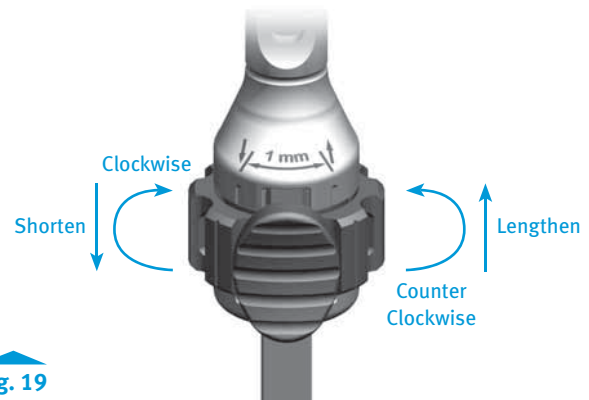

Fig. 19

TECHNIQUE TIP

2.A

It is recommended to use the 3-degree cut guide for a PS component and the 7-degree cut guide for a CR component. If the ultracongruent articular surface is to be used, the recommended tibial cut slope is 5-7 degrees. Biasing towards a flatter slope cut for the ultracongruent articular surface provides an opportunity to better match flexion and extension space, considering the flexion space generally increases more than the extension space when the PCL is resected.



Persona Tibial
Cut Guide
Right - 3°
42-5399-052-03



Persona Tibial
Cut Guide
Right - 7°
42-5399-052-07



Persona Tibial
Cut Guide
Universal - 3°
42-5399-050-03



Persona Tibial
Cut Guide
Universal - 7°
42-5399-050-07

Position Alignment Guide

- To improve the exposure of the tibial surface, retract the tibia anteriorly. Carefully position the retractor against the posterior cortex of the tibia subperiosteally to prevent neurovascular injury. Retract the patella laterally. Adjust the EM Alignment Guide to the approximate length of the tibia. Place the spring arms of the EM Ankle Clamp around the ankle proximal to the malleoli. Align the vertical slot in the cut guide with the medial third of the tibial tubercle.

TECHNIQUE TIP

2.B

Care should be taken when pinning into the tibia to avoid perforating the posterior cortex.

Adjust the height of the cut guide to the approximate desired location. Use the engraved line on the top of the cut guide to align the rotational and M/L placement guide (Fig. 20b). A 3.2mm pin or screw may be inserted through the 12mm vertical slot in the cut guide to secure the desired M/L and rotational position of the proximal portion of the guide (Fig. 20a).

Note: This pin will need to be removed to allow the "+2" or "+4" mm shifts with the cut guide.

Align the EM Alignment Guide with the mechanical axis of the tibia (Fig. 21a). The longitudinal axis will usually lie just medial to the mid-point of the tibial tubercle and be centered in line with the intercondylar eminence. The distal end of the EM Alignment Guide should be positioned about 5mm-10mm medial to the midpoint between the palpable medial and lateral malleoli. The short vertical engraved lines on the varus/valgus adjustment rail are incremented by 5mm to aid in setting the desired varus/valgus position of the EM Alignment Guide (Fig. 21b). Excessive soft tissue or poor exposure or visualization can make it difficult to palpate bony landmarks so care should be taken to ensure accurate cuts.

- Adjust the EM Alignment Guide in the sagittal plane to be parallel to the anterior tibial crest. A 3.2mm drill or the 3.2mm pin can be placed through the hole in the slot of the cut guide to help assess the expected slope of the tibial resection, and if desired, match the patient's specific anatomic slope (Fig. 22). As necessary, adjust the tibial slope of the EM Alignment Guide. If there is bulky bandage around the ankle or if there is excessive adipose tissue, the guide can be adjusted to create the desired slope. This will help ensure that the tibia will be cut with the proper slope. Care should be taken to avoid excessive posterior slope and to verify coronal alignment to the mechanical axis.

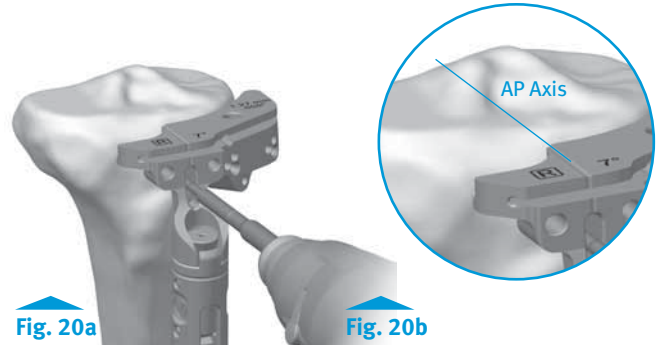

Fig. 20a

Fig. 20b

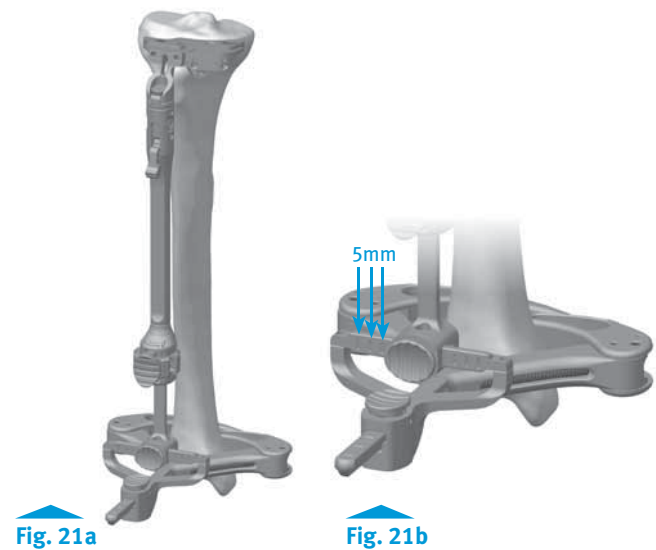

Fig. 21a

Fig. 21b

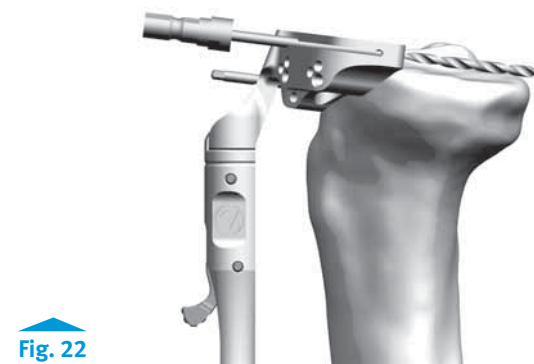

Fig. 22

Instruments



Persona EM
Proximal Tube
42-5399-001-00



Persona EM
Distal Rod
42-5399-002-00



Persona EM
Ankle Clamp
42-5399-003-00



3.2mm Drill
00-5120-085-00



75mm x 3.2mm
Trocar Tipped Drill
Pin (2.5mm hex)
00-5901-020-00



Pin/Screw
Insertor
00-5901-021-00



Persona Tibial
Cut Guide
Right - 7°
42-5399-052-07

Set Resection Level

- Each tip of the stylus indicates a different resection level. The 2mm tip is used to establish the resection level from the defective tibial condyle for a minimal cut. The 10mm tip is used to establish the resection level from the least involved tibial condyle.
- To assemble, push and hold the lever on the stylus and insert the stylus into the top of the cut guide and release the lever (**Fig. 23**). The stylus rotates and telescopes to facilitate desired positioning of the stylus tip.

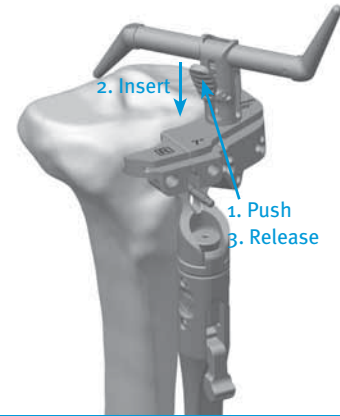

Fig. 23

TECHNIQUE TIP

2.C

*Boom tip must be in the vertical position to accurately assess resection level. Correct position is verified with an audible click as the boom twists. **WARNING:** An excessive bone resection will result if the boom is not in the vertical position.*

TECHNIQUE TIP

2.D

If using the top surface of the cut guide to make the resection, follow this technique for setting the resection level with the stylus. Then follow the optional technique at the end of this section. The stylus tips are calibrated to the cut slot

The 2mm tip should rest on the defective tibial condyle (**Fig. 24**). This positions the slot of the cut guide to remove 2mm of bone below the tip of the stylus.

Alternatively, rest the 10mm tip of the stylus on the cartilage of the least involved condyle (**Fig. 25**). This will allow the removal of the same amount of bone that the thinnest tibial component will replace. These two points of resection will usually not coincide. The surgeon must determine the appropriate level of resection based on patient's needs, such as age and bone quality. Rotate the micro-adjustment dial of the EM Proximal Tube to position the stylus and the cut guide to the desired level.



Fig. 24

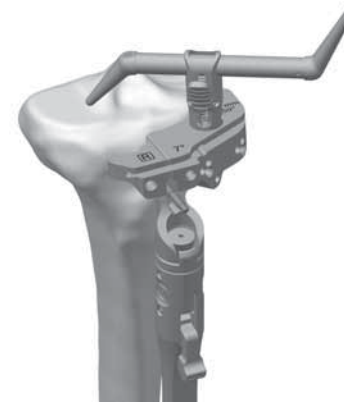

Fig. 25

TECHNIQUE TIP

2.E

When adjusting the height of the EM Alignment Guide steady the distal portion of the guide with one hand and use the other hand to adjust the height of the proximal portion of the guide.

Instruments



Persona Tibial
Cut Guide
Right - 7°
42-5399-052-07



Persona Tibial
Stylus - 2/10 mm
42-5399-005-00

A resection guide can be placed through the cut slot on the cut guide, to verify the desired level and slope of the resection (**Fig. 26**). Insert a 3.2mm trocar tipped pin through one of the "0" holes in the cut guide with the Pin/Screw Inserter. Ensure the cut guide is flush to the bone and not impeded by soft tissues before making the cut.



Fig. 26

- Insert a second trocar tipped pin through the other "0" hole in the cut guide with the Pin/Screw Inserter (**Fig. 27**). Remove the stylus by pushing the lever on the side of the stylus and remove.

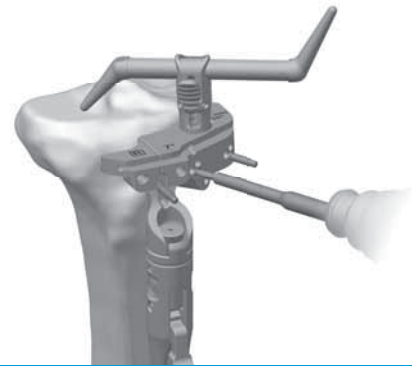

Fig. 27

To confirm alignment, insert the drop rod adapter into the cut guide and insert the alignment rod into the adapter (**Fig. 28**).

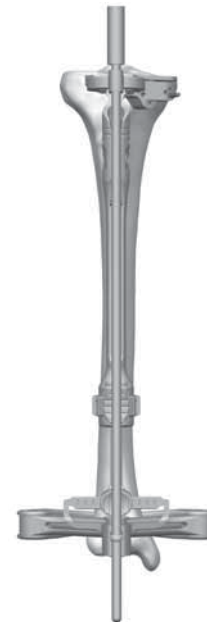

Fig. 28

Instruments



Persona Tibial Stylus - 2/10 mm
42-5399-005-00



Persona Drop Rod Adapter
42-5399-006-00



75mm x 3.2mm Trocar Tipped Drill Pin (2.5mm hex)
00-5901-020-00



Resection Guide
00-5977-084-00



Pin/Screw Inserter
00-5901-021-00



Alignment Rod with Coupler
00-5785-080-00



Persona Tibial Cut Guide Right - 7°
42-5399-052-07

Resect Proximal Tibia

- The entire EM Alignment Guide can be left in place for additional stability during resection. Optionally, the EM Alignment Guide can be removed by lifting the lever on the EM Proximal Tube up to the open position, translating the EM Alignment Guide anteriorly while leaving the cut guide in place (Fig. 29). If the EM Alignment Guide has been removed, additional 2mm adjustments may be made by shifting the cut guide to the sets of holes marked “+2”, and “+4”. The markings on the cut guide indicate, in millimeters, the amount of additional bone resection relative to the standard tibial resection set by the cut guide and stylus. If a pin or screw was inserted into the 12mm vertical slot, it will need to be removed to make the 2mm adjustments.

Once the resection level has been determined, insert a 3.2mm trocar tipped pin in the oblique hole indicated by a Lock Pin Symbol, to further secure the cut guide (Fig. 30a & Fig. 30b). If a pin or screw was inserted into the 12mm vertical slot, then a pin through the oblique hole may not be needed for secure fixation.

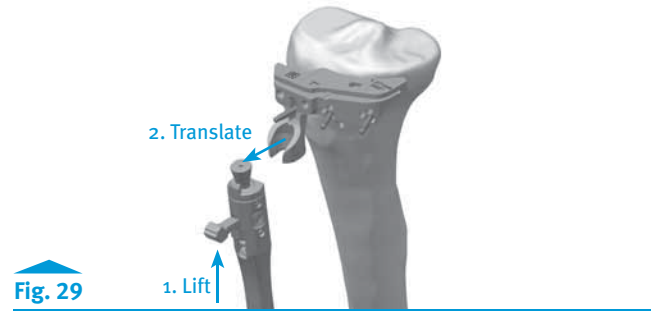

Fig. 29

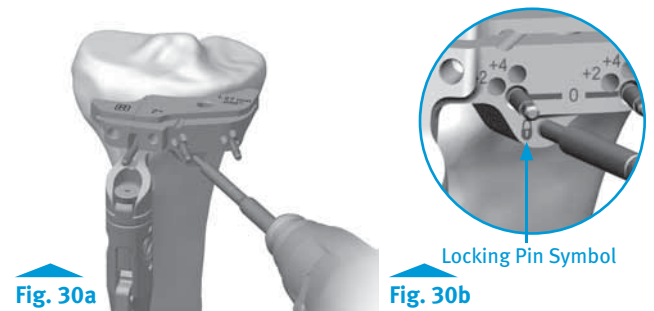

Fig. 30a

Fig. 30b

Optional Technique

- If desired, the resection can be made from the top surface of the cut guide. The top surface of the cut guide is 4mm above the cut slot (Fig. 31), therefore the position of the cut guide must be adjusted by moving the cut guide from the headless pins and reinserting the cut guide through the holes marked “+4” (Fig. 32).

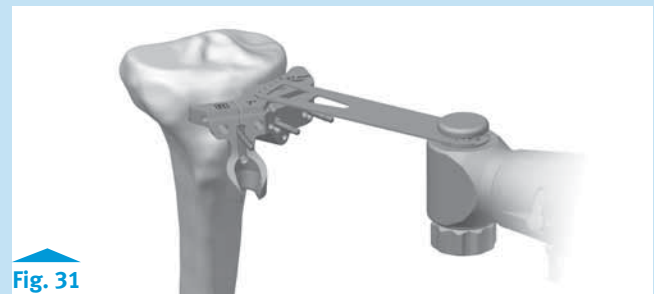

Fig. 31

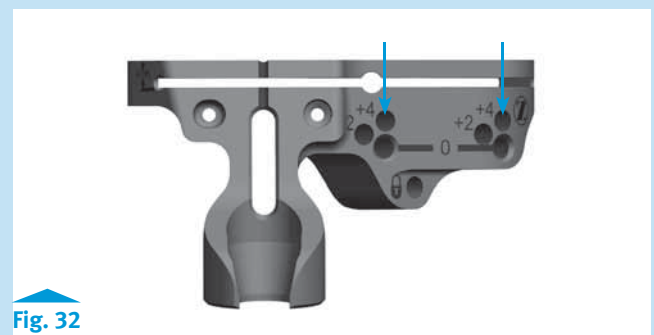

Fig. 32

Instruments



Persona Tibial
Cut Guide
Right - 7°
42-5399-052-07



75mm x 3.2mm
Trocar Tipped Drill
Pin (2.5mm hex)
00-5901-020-00



Pin/Screw
Inserter
00-5901-021-00



Multi Pin Puller
00-5901-022-00

TECHNIQUE TIP

2.F

The patellar tendon may be located behind the lateral side of the cut guide due to the patellar tendon relief cutout on the cut guide. Be careful to avoid cutting the patellar tendon when resecting the tibia.

- Use a 1.27mm (.050-in.) oscillating saw blade through the slot on the cut guide to resect the proximal surface of the tibia (Fig. 33).
- Prior to removing the cut guide, a contralateral or universal cut guide (of any angle) can be inverted and placed on the resected tibia to assure that a planar cut has been achieved (Fig. 34). If necessary, perform a clean-up cut.

Note: The flatness of the proximal tibial resection is critical to ensuring adequate contact between the porous tibial implant and the bone. If using a porous tibial implant, evaluate the flatness of the proximal tibial resection prior to drilling for the pegs. Modify the cut as necessary so that it is completely flat.

Remove oblique pins and the tibial cut guide.



Fig. 33



Fig. 34

TECHNIQUE TIP

2.G

If unable to complete the resection on the lateral side of the tibia, remove the cut guide, extend the knee and retract the soft tissue on the lateral side. If necessary, use an osteotome to complete the resection.

Instruments



75mm x 3.2mm
Trocar Tipped Drill
Pin (2.5mm hex)
00-5901-020-00



Pin/Screw
Insertor
00-5901-021-00



Multi Pin Puller
00-5901-022-00



Persona Tibial
Cut Guide
Right - 7°
42-5399-052-07

- If the cut guide has been removed, the drop rod adapter and alignment rod can be inserted into the holes on the inverted contralateral or universal cut guide (of any angle) to verify the desired tibial resection (**Fig. 35**).
- Remove all pins.



Fig. 35

Instruments



*Persona Tibial
Cut Guide
Right - 7°
42-5399-052-07*



*Persona Tibial
Cut Guide
Universal - 3°
42-5399-050-03*



*Persona Tibial
Cut Guide
Universal - 7°
42-5399-050-07*



*75mm x 3.2mm
Trocar Tipped Drill
Pin (2.5mm hex)
00-5901-020-00*



*Multi Pin Puller
00-5901-022-00*



*Persona Drop
Rod Adapter
42-5399-006-00*



*Alignment Rod
with Coupler
00-5785-080-00*

Size Femur and Establish External Rotation

- Rotate the feet of the anterior referencing femoral sizing guide so the appropriate “Left” or “Right” markings are visible as the femoral sizing guide is placed on the bone (Fig. 36). External rotation can be set at 3° or 5° from the posterior condylar axis.

TECHNIQUE TIP

3.A

Remove any osteophytes that interfere with instrument positioning.

- Apply the sizer so that the flat surface of the sizer is flush against the resected surface of the distal femur and the feet of the sizer are flush against the posterior condyles. Center the sizer mediolaterally. Both the vertical and horizontal portions of the sizer provide visual cues relative to the AP and epicondylar axes of the femur to help ensure that desired external rotation is attained.

Note: Sizer geometry is rotated 3° to align to the A/P and epicondylar axes of the femur. The 3° drill holes are rotated 3° from the posterior feet and are neutral to the central sizer geometry. This enables use of the A/P and epicondylar axis to set rotation.

- If the 3° external rotation holes are to be used to set external rotation, the etched line on the sizer should be positioned so it is in line with Whiteside’s line (Fig. 37) to optimize the M/L position of the drill holes for subsequent 4-in-1 Cut Guide placement. If the 5° external rotation holes are to be used, the sizer can be positioned with the etched line on the sizer 4mm laterally from Whiteside’s line to better center the drill holes for subsequent 4-in-1 cut guide placement, due to the M/L offset of the holes. Hold the guide in place and if necessary, secure the sizer to the femur using 25mm x 3.2mm (2.5mm female hex) screws (Fig. 38) in one or both of the holes on the lower portion of the guide to help draw the sizer adjacent to the distal femur, particularly in MIS situations.

Note: Do NOT use 48mm screws for fixation of the Anterior Reference Sizer. 48mm screws are not recommended due to potential bone perforation.

TECHNIQUE TIP

3.B

Do not impact the sizer onto the femur.

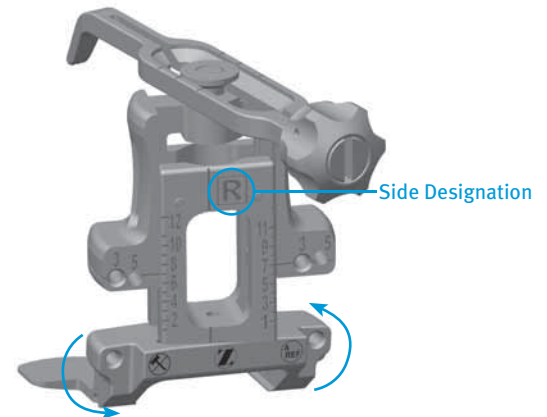
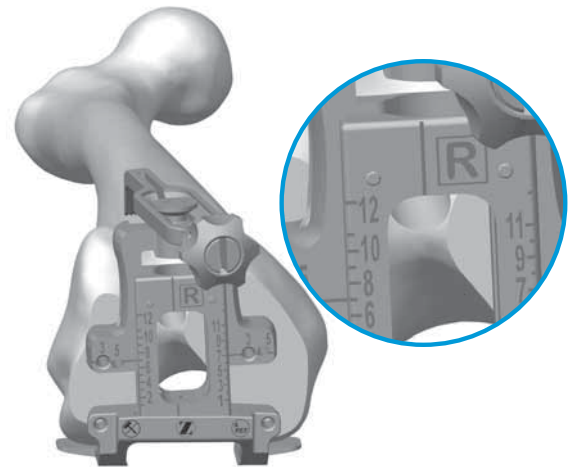
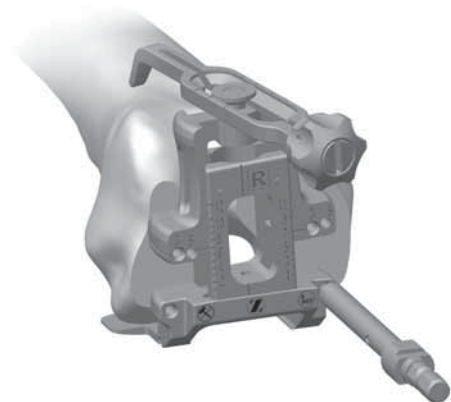
Fig. 36

Fig. 37

Fig. 38

Instruments



Persona Anterior
Referencing Sizer
42-5099-088-10



2.5mm Male
Hex Driver
42-5099-025-00



25mm x 2.5mm
Female Hex
Screw
42-5099-025-25

- Slightly extend the knee and retract soft tissues to expose the anterior femoral cortex. Clear any soft tissue from the anterior cortex. Ensure that the leg is in less than 90° of flexion (70°-80°). This will decrease the tension of the patellar tendon to facilitate placement of the sizing boom. The sizing boom telescopes proximally/distally to facilitate optimal placement along the anterior cortex. The engraved lines along the top of the boom approximate the anterior flange lengths of the size 1, 7, and 12 femoral components (Fig. 39a). Once the sizing boom is appropriately positioned, it should be locked in place by tightening the knob at the end of the boom clockwise (Fig. 39b).

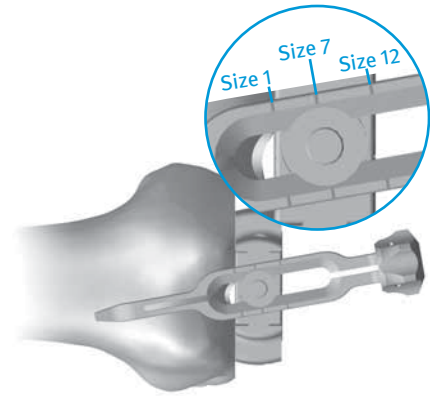

Fig. 39a

TECHNIQUE TIP 3.C

Lock boom after positioning to reduce the toggle of the boom tip. This will also reduce the risk of notching.

TECHNIQUE TIP 3.D

Positioning the sizing boom tip on the “high” part of the femur by lateralizing the location of the sizing boom tip can often lessen the likelihood of notching the femur.

TECHNIQUE TIP 3.E

To size accurately, the sizing boom should be telescoped to the size read from the tower. If the boom is telescoped to the exact size, the tip of the boom will approximate the exit point of the saw blade through the anterior cortex.

- After the sizer is appropriately positioned on the femur, read the femoral size from the engraved lines on the sizer tower and select the closest size (Fig. 40). There are six even-sizes labeled on the left side of the tower and six odd-sizes labeled on the right side of the tower, with lines indicating the in-between sizes. The 3° or 5° holes in the midline of the A/P portion of the sizer are used to drill 3.2mm holes for pegs on the Anterior Referencing 4-in-1 Femoral Cut Guide (Fig 41). A 3.2mm pin may be placed in the first drilled hole to maintain an “index” position prior to drilling the second hole. Remove the screws, then remove the sizer.

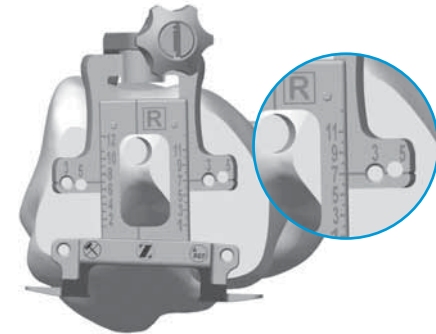

Fig. 40

TECHNIQUE TIP 3.F

The Multi Pin Puller cannot be used to extract the screw(s).

TECHNIQUE TIP 3.G

This Anterior Referencing Sizer works only with these Anterior Referencing 4-in-1 Femoral Cut Guides and Provisionals, and implants referenced in this technique.

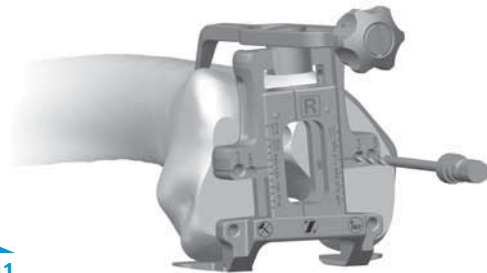

Fig. 41

Instruments

-  25mm x 2.5mm Female Hex Screw
42-5099-025-25
-  3.2mm Drill
00-5120-085-00
-  2.5mm Male Hex Driver
42-5099-025-00
-  Persona Anterior Referencing Sizer
42-5099-088-10

Complete Femoral A/P and Chamfer Resections

- By hand, place the 4-in-1 Cut Guide on the femur by aligning the 2 pins on the back of the guide with the previously drilled positioning holes (Fig. 42). Impact the face of the guide until the guide is flush with the femur. Place the Resection Guide through the anterior slot of the cut guide to ensure the desired anterior resection (Fig. 43). If inadequate bone will be removed from the anterior cortex, drill through the two holes on the face of the cut guide (Fig. 44a). Use the Slaphammer to axially remove the cut guide (Fig. 45a & 45b). Place the next smaller-sized femoral cut guide on the femur in the newly drilled “posteriorized” drill holes (Fig. 44a & 44b). Verify the anterior and posterior resection levels with the resection guide to assure that the desired resections will be attained. If too much posterior bone will be resected the original femoral cut guide can be used.

TECHNIQUE TIP

4.A

If the 2mm shift holes are to be used, assure that the desired holes on the distal femur are used. The resection guide can be used as final verification of the anticipated anterior and posterior resections.

TECHNIQUE TIP

4.B

If there is a risk of anterior notching, the 4-in-1 cut guide can be removed, rotated 180° and be replaced on the distal femur. Holes can then be drilled through the 2mm shift holes on the face of the 4-in-1 guide. The 4-in-1 guide then needs to be removed, rotated 180° and be placed on the distal femur in the anteriorized holes. This will result in a 2mm anterior shift of the 4-in-1 femoral resections. Using the resection guide, verify that the desired anterior and posterior resections will be attained.

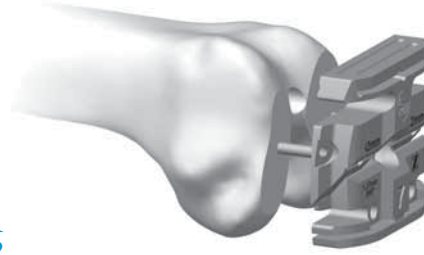

Fig. 42



Fig. 43

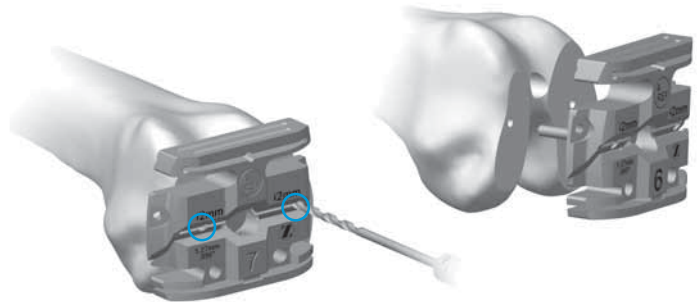

Fig. 44a

Fig. 44b

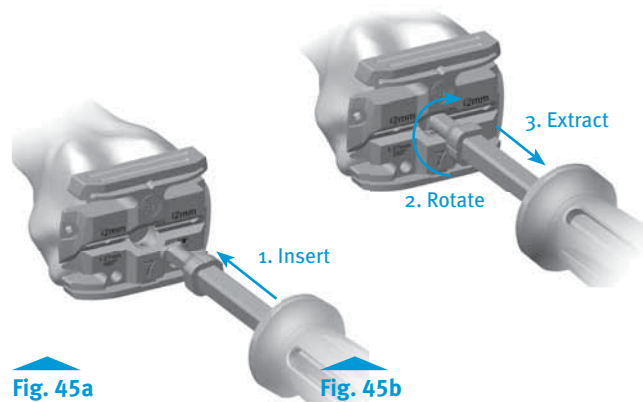

Fig. 45a

Fig. 45b

Instruments



Persona Anterior Referencing 4-in-1 Cut Guide - Size 7
42-5099-085-62



Resection Guide
00-5977-084-00



3.2mm Drill
00-5120-085-00



Persona Slaphammer
42-5099-037-00

Optional Instrument

The Shift Block can be used to internally or externally rotate the 4-in-1 Cut Guide 2 degrees and/or shift 1mm in the anterior or posterior direction. Refer to Appendix C: Optional Instruments: Shift Block, for use.

- After final placement of the desired Anterior Referencing 4-in-1 Cut Guide, insert 3.2mm trocar-tipped pins through the oblique holes in the Anterior Referencing 4-in-1 Cut Guide (Fig. 46).

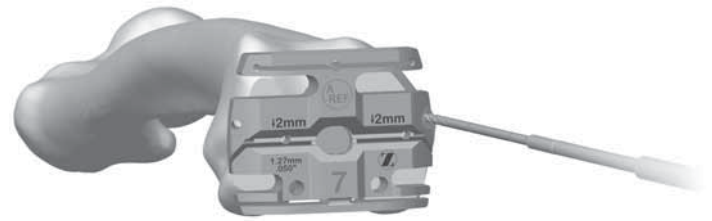

Fig. 46

Use a 1.27mm (.050 in.) thick oscillating saw blade to complete the anterior, posterior, posterior chamfer and anterior chamfer resections through the cut slots (Fig. 47). Upon completion of the cuts, use the Multi Pin Puller to remove the oblique pins.

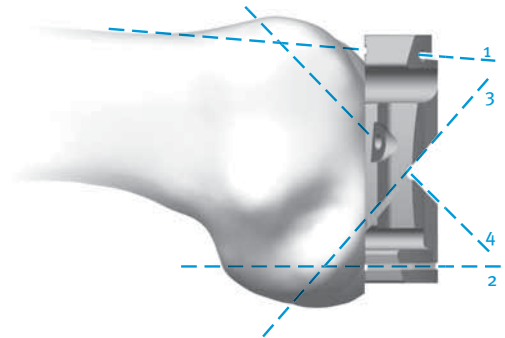

Fig. 47

Use the *Persona* Slaphammer to remove the cut guide from the femur insert slaphammer rotate 1/4 turn clockwise to engage the locking feature extract (Fig. 48a & 48b).

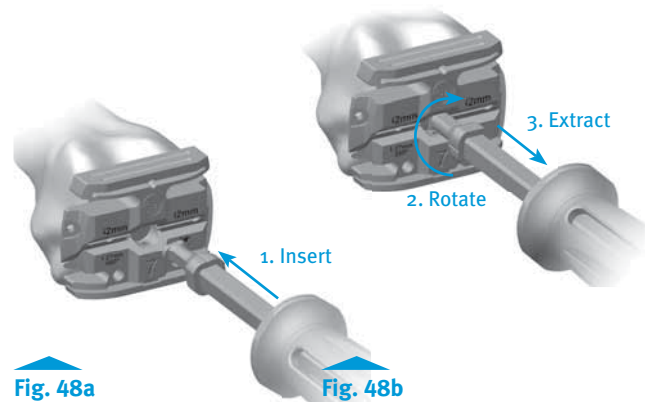

Fig. 48a

Fig. 48b

TECHNIQUE TIP

4.G

Completing the femoral resections in the order of anterior, posterior, posterior chamfer, and then anterior chamfer, the 4-in-1 cut guide will have the greatest stability.

Instruments

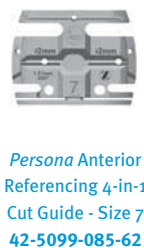

Establish Size and Rotation of Tibia

- Use only *Persona* tibial sizing, broaching and provisional instrumentation for preparation of *Persona* implants.
- Once tibial osteophytes have been thoroughly removed, select the appropriate right or left sizing plate that provides the desired tibial coverage, without overhang at any location. Appropriate tibial sizing is important as an over sized tibia component can result in overhang, soft tissue impingement and pain, or with stemmed components potential distal conflict between stem and bone.
- Attach the Tibial Sizing Plate Handle to the Cemented Tibial Sizing Plate (Fig. 49a). The recommended tibial rotational alignment is within 5° of the axis created by the medial 1/3 of the tibial tubercle and the PCL attachment point. The engraved lines on the Cemented Tibial Sizing Plate can be used to aid in establishing the desired tibial rotation. Rotate the Cemented Tibial Sizing Plate to attain the desired tibial rotational alignment. The notch in the lateral periphery of the sizing plate is used to establish proper position with respect to the lateral border of the tibia without medialization of the sizing plate.
- When the desired position has been attained, secure the Cemented Tibial Sizing Plate by placing 25mm x 3.2mm (2.5mm female hex) screws or 25mm x 3.2mm short head holding pins in the medial and lateral holes near the PCL cutout of the Cemented Tibial Sizing Plate (Fig. 49b). The remaining adjunct fixation holes shown on the surface of the Cemented Tibial Sizing Plate can be used if necessary. If the Cemented Tibial Sizing Plate is to be used as a provisional in later steps, male-headed screws/pins used in these holes must be removed prior to using the Tibial Articular Surface Provisionals (TASPs) (Fig 50). Ensure that the Cemented Tibial Sizing Plate remains in the proper position when securing it to the bone. Once desired alignment has been verified with the Alignment Rod, remove the Tibial Sizing Plate Handle from the Cemented Tibial Sizing Plate.

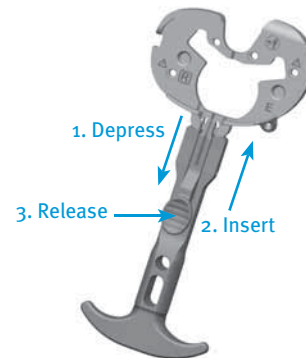

Fig. 49a



Fig. 49b

⚠ Male-headed Screws/Pins must be removed from these holes for Tibial Articular Surface Provisionals (TASP)

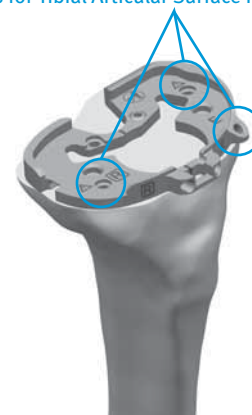

Fig. 50

TECHNIQUE TIP

5.A

Do not impact, lever, or pry the Tibial Sizing Plate Handle; this instrument is designed for alignment purposes only. Use the Alignment Rod in the hole or slot in the Tibial Sizing Plate Handle to verify proper tibial plate varus/valgus alignment. (See Appendix A for correcting varus/valgus resections)

TECHNIQUE TIP

5.B

If using a screw through the anterior medial hole on the periphery of the Cemented Tibial Sizing Plate, ensure that the Cemented Tibial Sizing Plate remains in the desired position and does not lift off posteriorly.

Instruments



Persona Tibial Sizing Plate Handle
42-5399-017-00



Persona Cemented Tibial Sizing Plate Size F Right
42-5399-075-02



Multi Pin Puller
00-5901-022-00



Alignment Rod with Coupler
00-5785-080-00



2.5mm Male Hex Driver
42-5099-025-00



25mm x 2.5mm Female Hex Screw
42-5099-025-25



25mm Shorthead Holding Pin
00-5977-056-03

Drill and Broach Tibia

- The keel of the tibial implant has a unique location for every size; therefore it is critical to select the proper size at this step, before drilling and broaching. Once these subsequent steps have been performed, the size should not be changed. If desired, femoral finishing can be performed in conjunction with provisional trialing at this stage to assure that the desired range-of-motion and soft tissue balance can be attained with the Cemented Tibial Sizing Plate in place prior to drilling and broaching the tibia.
- By hand, place and hold the Cemented Tibial Drill Guide on the tibia Cemented Tibial Sizing Plate, by first engaging the posterior tabs in the undercuts in the Cemented Tibial Sizing Plate and then making sure that the distal anterior portion of the Cemented Tibial Drill Guide is flush against the Cemented Tibial Sizing Plate (**Fig. 51a**).

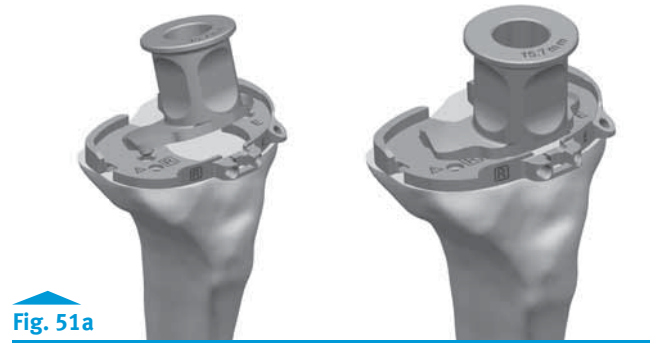

Fig. 51a

Use the Cemented Tibial Drill and drill until the center of the size-specific engraved line on the Cemented Tibial Drill is in line with the top of the Cemented Tibial Drill Guide (**Fig. 51b**). After drilling is complete, remove the Cemented Tibial Drill and Cemented Tibial Drill Guide.

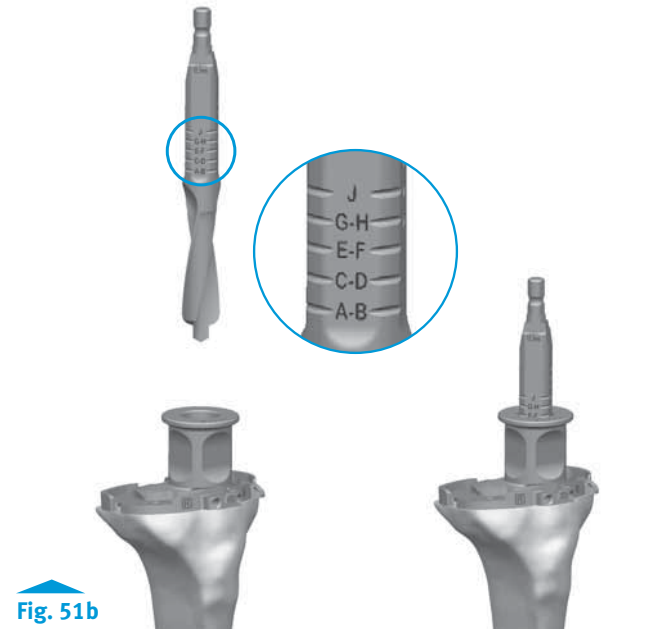

Fig. 51b

TECHNIQUE TIP

6.A

Insert Cemented Tibial Drill into Cemented Tibial Drill Guide prior to starting Cemented Tibial Drill. By hand, hold the Cemented Tibial Drill Guide flush against the Cemented Tibial Sizing Plate while drilling.

Instruments



Persona
Cemented Tibial
Drill, 15.7mm
42-5399-018-10



Persona
Cemented Tibial
Drill Guide -
15.7mm
42-5399-020-00

Optional Technique

- If desired, the Cemented Tibial Drill Stop Collar, may be used to aid in drilling to the correct depth. Depress the button on the Cemented Tibial Drill Stop Collar and slide the Cemented Tibial Drill Stop Collar to the desired size-specific position on the Cemented Tibial Drill (**Fig. 52**).
- Confirm that the correct size is displayed in the Cemented Tibial Drill Stop Collar window (**Fig. 53**) and that the Cemented Tibial Drill Stop Collar is locked on the Cemented Tibial Drill.

TECHNIQUE TIP**6.B**

Verify that the Cemented Tibial Drill Stop Collar is locked on the Cemented Tibial Drill by attempting to slide the Cemented Tibial Drill Stop Collar on the Cemented Tibial Drill by hand. The Cemented Tibial Drill Stop Collar will make an audible click when it locks on the Cemented Tibial Drill.

TECHNIQUE TIP**6.C**

Insert Cemented Tibial Drill into Cemented Tibial Drill Guide prior to drilling.

- After positioning the Cemented Tibial Drill Stop Collar in the proper position, drill through the Cemented Tibial Drill Guide until the Cemented Tibial Drill Stop Collar contacts the Cemented Tibial Drill Guide (**Fig. 54**). After drilling is complete, remove the Cemented Tibial Drill and Cemented Tibial Drill Guide from the Cemented Tibial Sizing Plate.

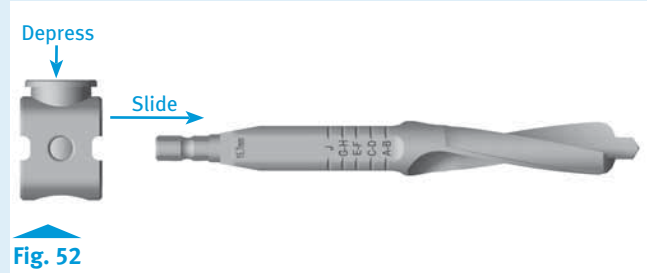
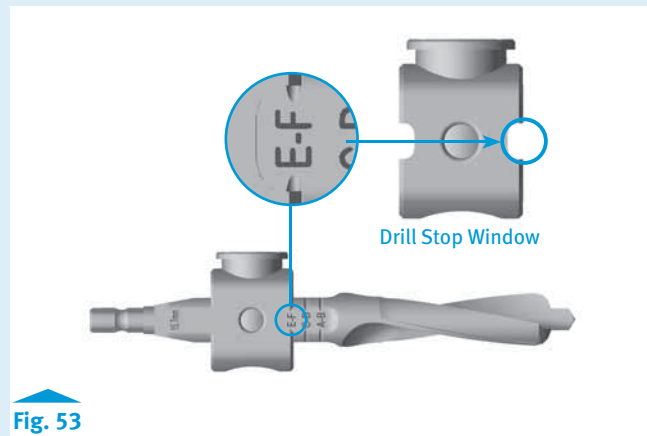
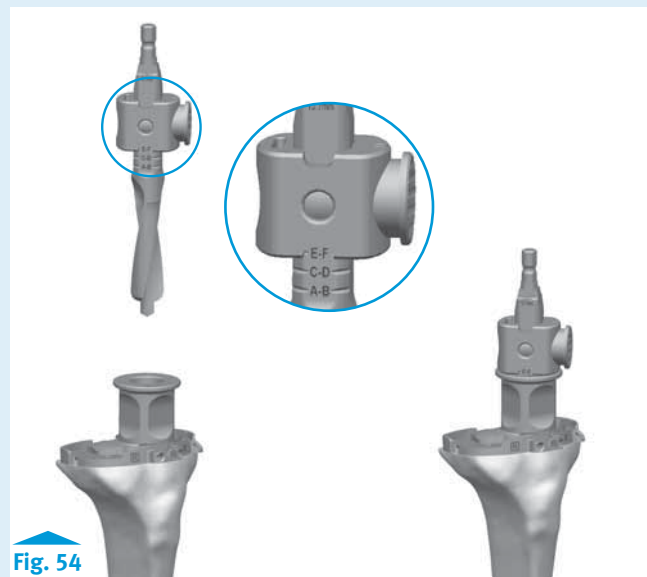
**Fig. 52****Fig. 53****Fig. 54****Instruments**

Persona Tibial
Sizing Plate
Handle
42-5399-017-00



Persona
Cemented Tibial
Sizing Plate Size
F Right
42-5399-075-02



Persona
Cemented Tibial
Drill, 15.7mm
42-5399-018-10



Persona
Cemented Tibial
Drill Guide -
15.7mm
42-5399-020-00



Persona
Cemented Tibial
Drill Stop Collar,
15.7mm
42-5399-019-00

- Insert the correct-sized Cemented Tibial Broach into the Cemented Tibial Broach Inserter/Extractor Handle, (Fig. 55). Retract the impaction head until it locks in the fully retracted position, which will facilitate placement on the Cemented Tibial Sizing Plate. After seating the Cemented Tibial Broach Inserter/Extractor Handle on the Cemented Tibial Sizing Plate, tap the impaction head once to seat the Cemented Tibial Broach. Impact the Cemented Tibial Broach Inserter/Extractor Handle assembly with care to prevent fracture of the tibia (Fig. 56). Impact until the impaction head bottoms out on the Cemented Tibial Broach Inserter/Extractor Handle stop (Fig. 56 inset). While holding the Cemented Tibial Broach Inserter/Extractor Handle, impact the extraction button to remove the Cemented Tibial Broach from the bone (Fig 57). Avoid dislodging the Cemented Tibial Sizing Plate when removing the Cemented Tibial Broach Inserter/Extractor Handle.

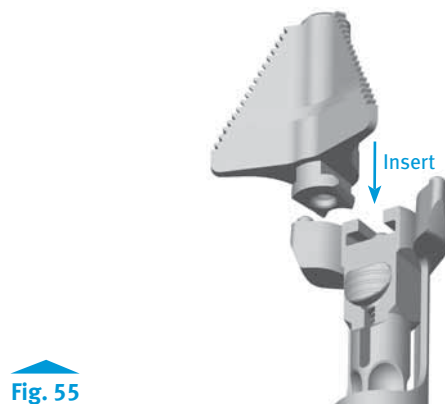

Fig. 55

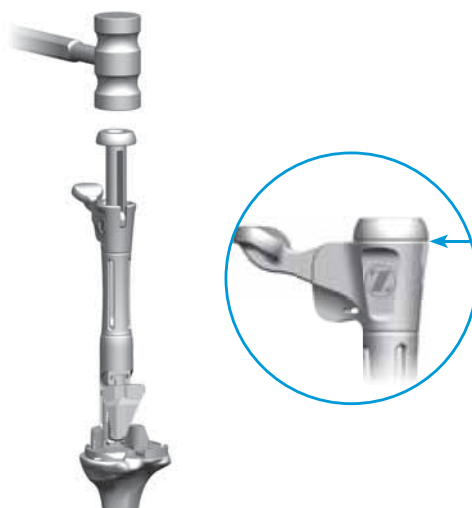

Fig. 56

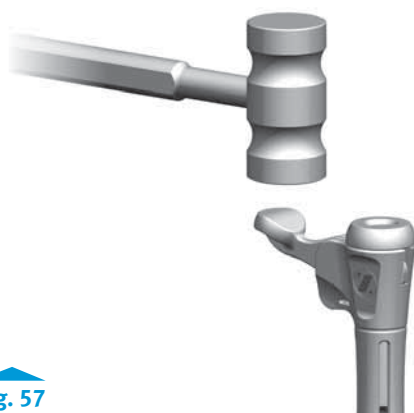

Fig. 57

TECHNIQUE TIP

6.D

Assure that no metallic debris is present on the magnetic feet of the Cemented Tibial Broach Inserter/Extractor Handle as this may inhibit the mating with the Cemented Tibial Sizing Plate and may introduce unwanted debris into the surgical site.

TECHNIQUE TIP

6.E

Make sure that the Cemented Tibial Broach Inserter/Extractor Handle remains flush against the Cemented Tibial Sizing Plate and in full contact with the Cemented Tibial Sizing Plate and that the Cemented Tibial Broach Inserter/Extractor Handle does not tip during impaction. The orientation of the Cemented Tibial Broach Inserter/Extractor Handle is important to ensure proper and complete broaching resulting in full seating of the tibial implant on the bone.

TECHNIQUE TIP

6.F

DO NOT extract with mallet blows on either the medial or lateral side of the under surface of the impaction head of the Cemented Tibial Broach Inserter/Extractor Handle. **DO NOT** attempt to extract the Cemented Tibial Broach with a horizontal or angled blow on any side of the Cemented Tibial Broach Inserter/Extractor Handle.

Instruments



Persona
Cemented Tibial
Broach Size EF
42-5399-022-05



Persona
Cemented Tibial
Broach Inserter/
Extractor Handle
42-5399-023-00



Persona
Cemented Tibial
Sizing Plate Size
F Right
42-5399-075-02

Prepare the Patella

Please refer to the appropriate surgical technique if other patellar preparation instrumentation is to be used to accomplish patella preparation.

TECHNIQUE TIP

7.A

These instruments are designed for onlaying all-poly patella only.

- Place the leg in full extension, evert the patella to at least 90°. Stabilize the patella, using two inverted towel clips. Incise the soft tissue around the patella down to the insertion of the quadriceps and patellar tendons. Before making any bone cuts, determine the maximum thickness of the patella by using the Femur Caliper to measure the most prominent anterior-to-posterior dimension (Fig. 58).

TECHNIQUE TIP

7.B

The Femur Caliper has a tolerance of ± 0.25 mm.

- Refer to the sizing chart for patella dimensions (Fig. 59). Use a 3.2mm drill to drill the highest portion of the medial facet perpendicular to the articular surface approximately 12mm deep centered on the medial sagittal ridge (Fig. 60). This acts as a guide for proper medialization of the patella.
- Use the Patella Osteotomy Guide with the stylus set for the desired amount of resection. Depress the button on the stylus while twisting to set the stylus at the desired resection level (Fig. 61). If the patella is very worn, resect less bone.

TECHNIQUE TIP

7.C

Assure that the Patella Osteotomy Guide stylus is referencing the most prominent point on the patella before resecting.

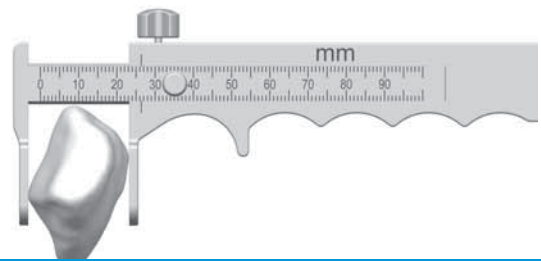

Fig. 58

Patella Size and Thickness

Persona Standard Implant

26mm x 7.5mm*
29mm x 8.0mm**
32mm x 8.5mm**
35mm x 9.0mm
38mm x 9.5mm
41mm x 10.0mm

*The 26mm patella must always be inset.

**The 29mm and 32mm patellae must be inset when used with sizes 10-12 Persona PS femoral components.

See package insert for complete details.

Fig. 59

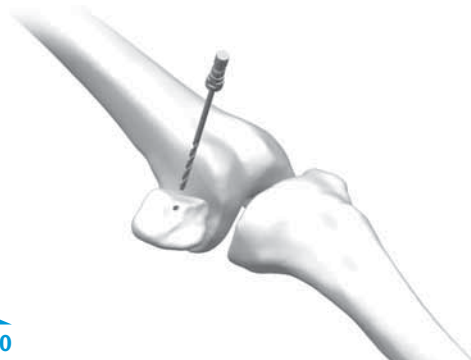

Fig. 60

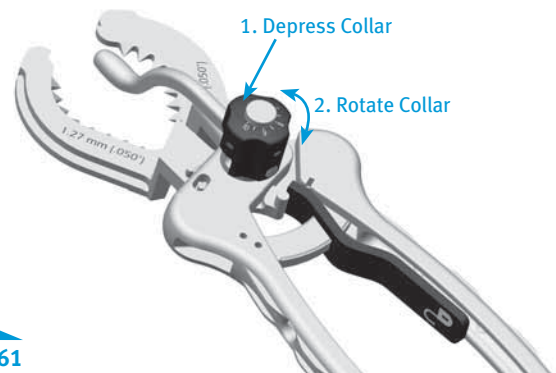

Fig. 61

Instruments

Femur Caliper
00-5903-030-003.2mm Drill
00-5120-085-00

- Apply the Patella Osteotomy Guide medially and laterally with the jaws at the osteochondral juncture with the handles of the jig oriented toward the foot. Apply the guide with the jaws parallel to the dorsal surface of the patella, while positioning the Patella Osteotomy Guide stylus over the most prominent point on the patella. Make the resection with a 1.27mm (.050 in) thick saw blade (Fig. 62). Cut the patella flat so that a smooth surface remains.

Fig. 62



TECHNIQUE TIP

7.D

To facilitate unlocking the Patella Osteotomy Guide from the patella, apply slight gripping pressure on the handles of the Patella Osteotomy Guide and depress the release lever to unlock the Patella Osteotomy Guide (Fig. 63).

Fig. 63

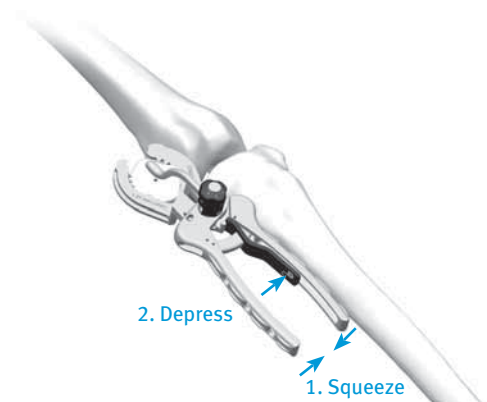

TECHNIQUE TIP

7.E

Do not drill through the center hole of the NexGen Patella Sizing Template.

TECHNIQUE TIP

7.F

Eccentric placement of the patella 3-4mm medially allows for better patella tracking.

Fig. 64



Patella Osteotomy Guide
00-5903-010-00

NexGen Patella Sizing Template
00-5903-041-00

- Insert the appropriately-sized *NexGen* Patella Peg Drill Guide into the Patella Clamp in the proper orientation (**Fig. 65**). Place the Patella Clamp with the *NexGen* Patella Peg Drill Guide over the cut surface of the patella, centered slightly toward the medial facet over the 3.2mm drill hole with the clamp oriented so two of the holes are biased toward the medial side of the patella (**Fig. 66**).

TECHNIQUE TIP

7.G

For hard/sclerotic bone it may be necessary to impact the NexGen Patella Peg Drill Guide face to fully seat the drill guide. This is necessary to assure that adequate bone removal is attained during drilling to fully seat the implant.

- Use the *NexGen* 6.4mm Patella/Femoral Drill to drill through the 3 peg holes in the *NexGen* Patella Peg Drill Guide (**Fig. 67**).

TECHNIQUE TIP

7.H

*To facilitate unlocking the Patella Clamp from the patella, apply slight gripping pressure on the handles of the Patella Clamp and depress the release lever to unlock the Patella Clamp (**Fig. 68**).*



Fig. 65



Fig. 66



Fig. 67

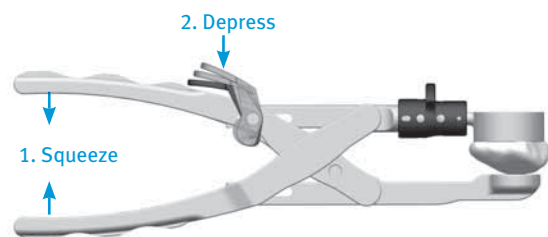

Fig. 68

Instruments



NexGen Patella Peg
Drill Guide Sizes
29, 32, 35, 38, 41
00-5903-023-29/41



Patella Clamp
00-5903-020-00



NexGen 6.4mm
Patella/Femoral
Drill
00-5120-052-01

CR Femoral Finishing and Trialing

TECHNIQUE TIP

8.A

Reference the orientation and size etched and/or engraved markings to identify the correct provisional.

- Assemble the Femoral CR Impactor Pad to the Femoral Inserter/Extractor. Hold the Femoral Inserter/Extractor with the handle in the open position and insert the Femoral CR Impactor Pad, aligning the "CR" on the Femoral CR Impactor Pad with the arrow on the Femoral Inserter/Extractor (**Fig. 69a**). The Femoral CR Impactor Pad is keyed, so the Femoral CR Impactor Pad may have to be rotated while placing and aligning the Femoral CR Impactor Pad onto the Femoral Inserter/Extractor.
- Femoral sizes 3 through 11 are provided in two profiles, Standard and Narrow. The size 3 through 11 Standard Femoral Provisionals have intermittent cutouts around the periphery, with the inner dimension representing the outer profile of the Narrow femoral implant and the outer dimension representing the outer profile of the Standard femoral implant (**Fig. 69b**). Femoral sizes 1 and 2 are provided in one profile, Narrow; and femoral size 12 provided in one profile, Standard. Thus the size 1, 2 and 12 Femoral Provisionals do not have intermittent cutouts. Care should be taken to use the appropriate Standard or Narrow implant as is related to side (left or right) and size based on the provisional fit and ROM provided during the trialing phase.

TECHNIQUE TIP

8.B

Do not impact the anterior flange of the CR Femoral Provisional. Do not impact the medial or lateral aspects or the release lever of the Femoral Inserter/Extractor.

- Remove any posterior osteophytes or overhanging bone on the femur to facilitate maximum knee flexion. Attach the Femoral Inserter/Extractor to the correct CR Femoral Provisional by inserting the hook on the Femoral Inserter/Extractor arm into the anterior notch in the CR Femoral Provisional and close the handle on the Femoral Inserter/Extractor to secure the CR Femoral Provisional (**Fig. 70**).

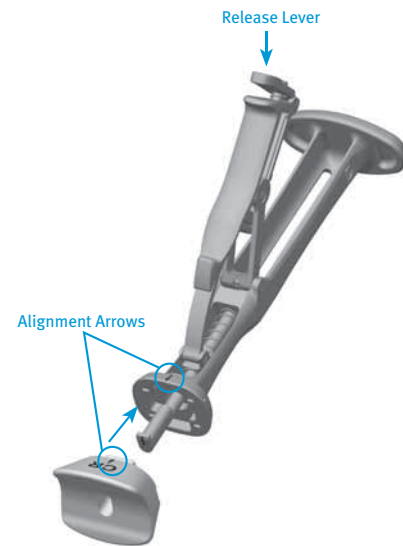

Fig. 69a

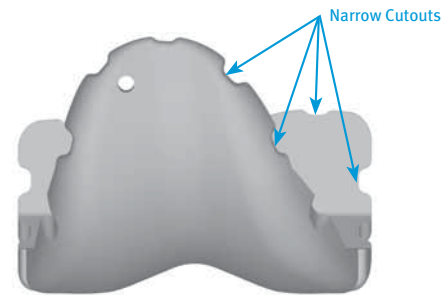

Fig. 69b

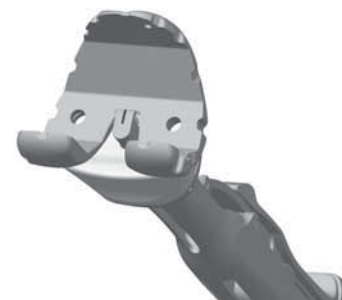

Fig. 70

Instruments



Persona Femoral Inserter/Extractor
42-5099-092-00



Persona Femoral CR Impactor Pad
42-5099-094-00



Persona CR Femoral Provisional
Size 7 Right
42-5027-062-02

Place the correct CR Femoral Provisional onto the femur in the desired medial/lateral position. Impact the end of the Femoral Inserter/Extractor handle to fully seat the CR Femoral Provisional onto the femur (**Fig. 71**). To remove the Femoral Inserter/Extractor from the CR Femoral Provisional, pinch the release lever while pulling out/down (**Fig. 71**). Alternatively, if the CR Femoral Provisional is placed on the femur by hand, the Femoral Inserter/Extractor handle must be in the closed and locked position prior to engaging the CR Femoral Provisional. Then the Femoral Inserter/Extractor can be used to impact the provisional onto the femur. For additional fixation of the fully seated provisional, insert the 25mm x 3.2mm screw (2.5mm female hex) with the 2.5mm male hex driver through the hole in the lateral anterior flange of the CR Femoral Provisional (**Fig. 72**).

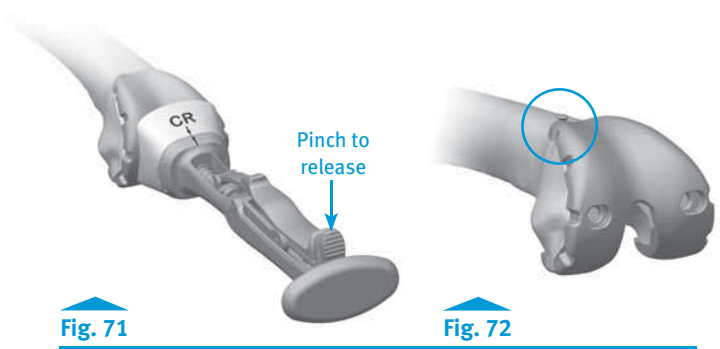

TECHNIQUE TIP **8.C**

Ensure the shoulder of drill is seated at bottom of the Femoral Provisional counterbore.

- If the tibia has been prepared, a trial range of motion can be performed to assure proper positioning of the CR Femoral Provisional prior to femoral peg hole preparation. Once desired medial-lateral placement has been attained, drill the peg holes for size 3 through 12 femoral implants through the CR Femoral Provisional with the NexGen 6.4mm Patella/Femoral Drill (**Fig 73**). For size 1 and 2 femoral implants use the NexGen 4.4mm Femoral Peg Drill. If a screw was used to provide adjunct fixation, remove the screw from the anterior flange in the CR Femoral Provisional. The Slaphammer can be used to remove size 3 through 12 CR Femoral Provisionals (**Fig. 74**). Rotate the Slaphammer a ¼ turn outward. For size 1 and 2 CR Femoral Provisionals the Slaphammer can be inserted into the notch on the medial or lateral side of the provisional. Alternatively, the Femoral Inserter/Extractor can be re-attached to the CR Femoral Provisional to remove it from the bone. If necessary, place the round end of the Slaphammer in the extraction hole of the Femoral Inserter/Extractor to facilitate removal.

TECHNIQUE TIP **8.D**

Ensure oval hole of the femoral provisional is free of debris prior to inserting slaphammer.

TECHNIQUE TIP **8.E**

If trialing with TASP leave femoral provisional in place until trialing is complete.

TECHNIQUE TIP **8.F**

Do not impact the anterior flange of the CR Femoral Provisional for removal, as this may damage the CR Femoral Provisional.

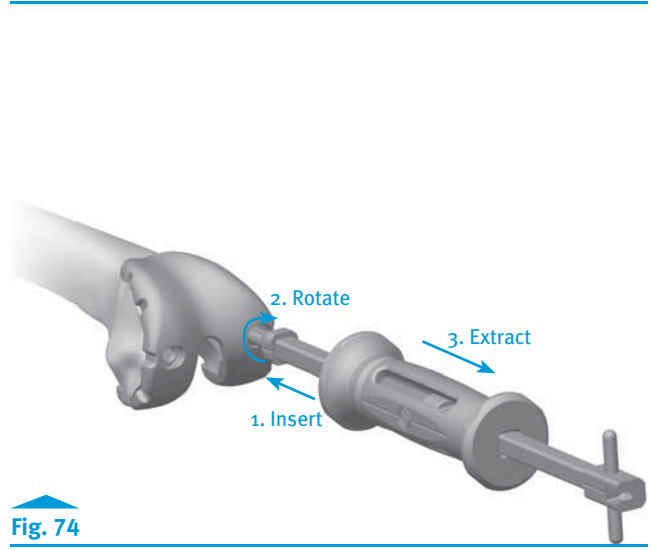

Instruments

							
Persona Femoral Inserter/Extractor 42-5099-092-00	Persona Femoral CR Impactor Pad 42-5099-094-00	Persona CR Femoral Provisional Size 7 Right 42-5027-062-02	25mm x 2.5mm Female Hex Screw 42-5099-025-25	NexGen 6.4mm Patella/Femoral Drill 00-5120-052-01	Persona Slaphammer 42-5099-037-00	2.5mm Male Hex Driver 42-5099-025-00	NexGen 4.4mm Femoral Drill for size 1 and 2 Femoral Provisionals 00-5965-009-00

PS Femoral Finishing and PS Box Preparation

TECHNIQUE TIP

9.A

Reference the orientation and size etched and/or engraved markings to identify the correct provisional.

- Assemble the Femoral PS Impactor Pad to the Femoral Inserter/Extractor. Hold the Femoral Inserter/Extractor, with the handle in the open position and insert the Femoral PS Impactor Pad, aligning the "PS" on the Femoral PS Impactor Pad with the arrow on the Femoral Inserter/Extractor (Fig. 75a). The Femoral PS Impactor Pad is keyed, so the Femoral PS Impactor Pad may have to be rotated while placing and aligning the Femoral PS Impactor Pad onto the Femoral Inserter/Extractor.

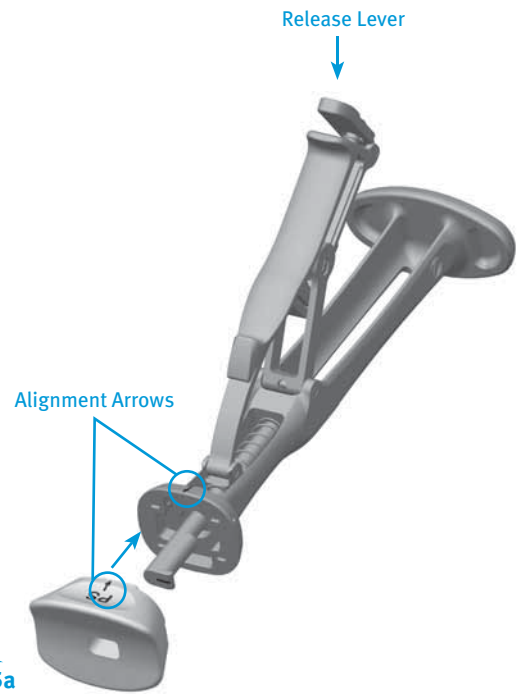

Fig. 75a

- Femoral sizes 3 through 11 are provided in two profiles, Standard and Narrow. The size 3 through 11 Standard Femoral Provisionals have intermittent cutouts around the periphery, with the inner dimension representing the outer profile of the Narrow femoral implant and the outer dimension representing the outer profile of the Standard femoral implant (Fig. 75b). Femoral sizes 1 and 2 are provided in one profile, Narrow; and Femoral size 12 provided in one profile, Standard. Thus the size 1, 2 and 12 Femoral Provisionals do not have intermittent cutouts. Care should be taken to use the appropriate Standard or Narrow implant as is related to side (left or right) and size based on the provisional fit and ROM provided during the trialing phase.

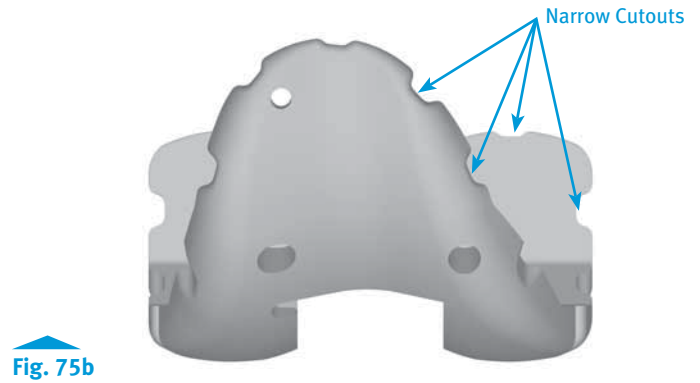

Fig. 75b

Instruments



Persona Femoral Inserter/Extractor
42-5099-092-00



Persona Femoral PS Impactor Pad
42-5099-093-00



Persona PS Femoral Provisional Size 7 Right
42-5007-062-02

TECHNIQUE TIP

9.B

Do not impact the anterior flange of the PS Femoral Provisional.
Do not impact the medial or lateral aspects or the release lever of the Femoral Inserter/Extractor.

- Remove any posterior osteophytes or overhanging bone on the femur to facilitate maximum knee flexion. Attach the Femoral Inserter/Extractor to the correct PS Femoral Provisional by inserting the hook on the Femoral Inserter/Extractor arm into the lateral notch in the PS Femoral Provisional and close the handle on the Femoral Inserter/Extractor to secure the PS Femoral Provisional (Fig. 76).

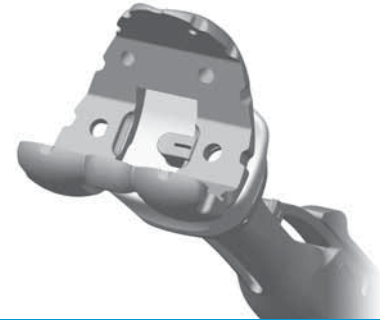

Fig. 76

Place the correct PS Femoral Provisional onto the femur in the desired medial/lateral position. Impact the end of the Femoral Inserter/Extractor handle to fully seat the PS Femoral Provisional onto the femur (Fig. 77). To remove the Femoral Inserter/Extractor from the PS Femoral Provisional, pinch the release lever while pulling out/down (Fig. 77).

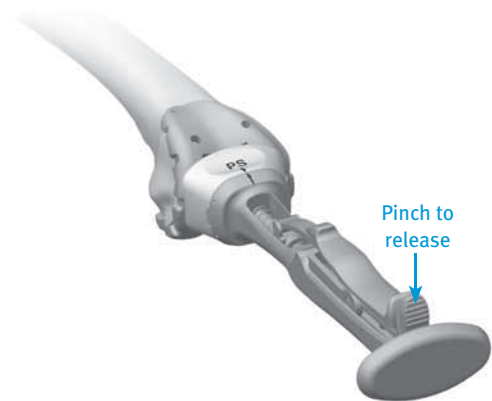

Fig. 77

Alternatively, if the PS Femoral Provisional is placed on the femur by hand, the Femoral Inserter/Extractor handle must be in the closed and locked position prior to engaging the PS Femoral Provisional. Then the Femoral Inserter/Extractor can be used to impact the provisional onto the femur. For additional fixation of the fully seated PS Femoral Provisional, insert the 25mm x 3.2mm screw (2.5mm female hex) with the 2.5mm Male Hex Driver through the hole in the lateral anterior flange of the PS Femoral Provisional (Fig. 78a).

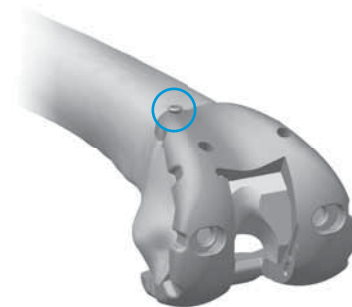

Fig. 78a

Instruments



Persona Femoral
Inserter/Extractor
42-5099-092-00



Persona Femoral
PS Impactor Pad
42-5099-093-00



Persona PS
Femoral Provisional
Size 7 Right
42-5007-062-02



2.5mm Male
Hex Driver
42-5099-025-00



25mm x 2.5mm
Female Hex
Screw
42-5099-025-25

- By hand, insert and hold the correct-sized PS Box Cut Guide into the anterior holes of the PS Femoral Provisional (Fig. 78b). For additional fixation of the fully seated PS Box Cut Guide, insert the 25mm x 3.2mm screw (2.5mm female hex) with the 2.5mm Male Hex Driver through one of the holes in the PS Box Cut Guide. Separate PS Box Cut Guides exist for the PS Femoral Provisional for sizes 1-2, 3-5, 6-9, and 10-12.

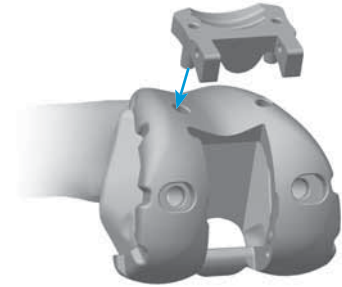

Fig. 78b

TECHNIQUE TIP

9.C

Do not impact the PS Box Cut Guide into the provisional.

- Make the anterior to posterior PS box cut with a 1.27mm (.050 in.) thick, 1/2" wide oscillating or reciprocating saw blade, by resting the saw blade in a parallel manner on the front surface of the PS Box Cut Guide. Avoid undercutting the medial and lateral condyles. This is particularly important for smaller femurs (Fig. 79a).

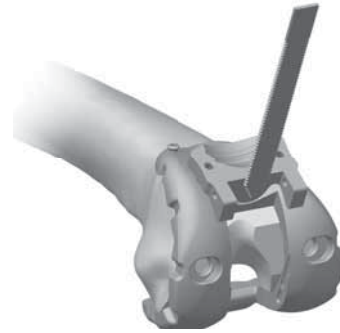

Fig. 79a

After completing the anterior-to-posterior box cut, make the vertical wall cuts for the PS notch cuts by resting the saw blade in a parallel manner against the interior sidewalls of the PS Femoral Provisional (Fig. 79b).

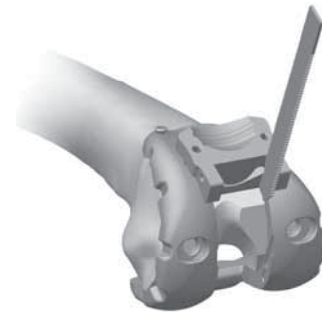

Fig. 79b

Instruments



Persona PS
Femoral Provisional
Size 7 Right
42-5007-062-02



Persona PS Box
Cut Guide 6-9
42-5099-060-03



2.5mm Male
Hex Driver
42-5099-025-00



25mm x 2.5mm
Female Hex
Screw
42-5099-025-25

TECHNIQUE TIP

9.D

Keep blades against the support features of the Cut Guide and Femoral Provisional to ensure adequate bone resection. The cut planes (A/P and vertical) extend below the top of the PS cam.

TECHNIQUE TIP

9.E

Align the raised bumps on the exterior side walls of the Box Provisional with the grooves in the interior sidewalls of the Femoral Provisional.

- If a screw was used to provide adjunct fixation, remove the screw and the PS Box Cut Guide. By hand, insert the correct-sized PS Box Provisional into the PS Femoral Provisional to assure that adequate bone has been removed for the implant AND for proper patella trialing. Separate left and right PS Box Provisionals exist for sizes 1-2, 3-5, 6-9, and 10-12 PS Femoral Provisionals (Fig. 80). The Constrained Posterior Stabilized (CPS) cut slot must be used if a CPS articular surface is selected. The CPS cut slot may also be used for PS box resections. Additional information for this product may be found in the Constrained Posterior Stabilized (CPS) Surgical Technique (97-5026-072-00).

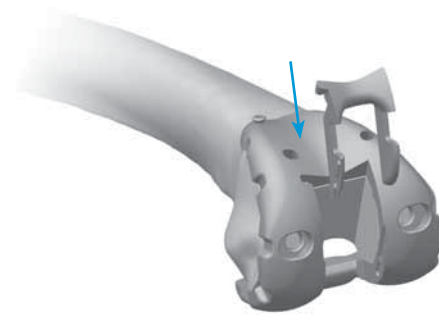

Fig. 80

TECHNIQUE TIP

9.F

If the appropriately sized PS Box Provisionals does not easily seat into the PS Femoral Provisional, perform clean up cuts to assure adequate bone has been removed. Do **NOT** impact the PS Box Provisional. Make sure the PS Femoral Provisional is fully seated after inserting the correct PS Box Provisional.

Instruments



2.5mm Male
Hex Driver
42-5099-025-00



25mm x 2.5mm
Female Hex
Screw
42-5099-025-25



Persona PS Box
Cut Guide 6-9
42-5099-060-03



Persona PS
Box Provisional
6-9 Right
42-5007-060-12

TECHNIQUE TIP 9.G

Ensure the shoulder of drill is seated at bottom of the Femoral Provisional counterbore.

- Drill the pegs holes for the size 3 through 12 femoral implants through the PS Femoral Provisionals with the NexGen 6.4mm Patella/Femoral Drill (Fig. 81). The size 1 and 2 femoral components do not have pegs thus drilling is not required for those sizes. Remove the screw from the anterior flange in the PS Femoral Provisional. Remove the PS Box Provisional. The Slaphammer can be used to remove size 3 through 12 PS Femoral Provisionals (Fig. 82). Rotate the Slaphammer a ¼ turn outward. For size 1 and 2 PS Femoral Provisionals the Slaphammer can be inserted into the notch on the medial or lateral side of the provisional. Alternatively, the Femoral Inserter/Extractor can be re-attached to the PS Femoral Provisional to remove it from the bone. If necessary, insert the Slaphammer in the extraction hole of the Femoral Inserter/Extractor to facilitate removal.

TECHNIQUE TIP 9.H

Ensure oval hole of the femoral provisional is free of debris prior to inserting slaphammer.

TECHNIQUE TIP 9.I

If trialing with TASP leave femoral provisional in place until trialing is complete.

TECHNIQUE TIP 9.J

Do not impact the anterior flange of the PS Femoral Provisional for removal, as this may damage the PS Femoral Provisional.

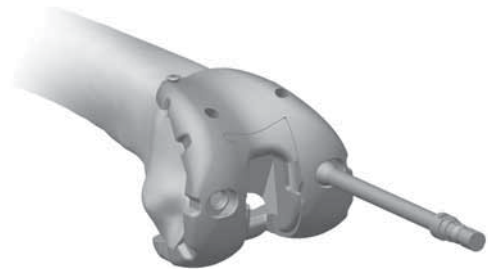

Fig. 81

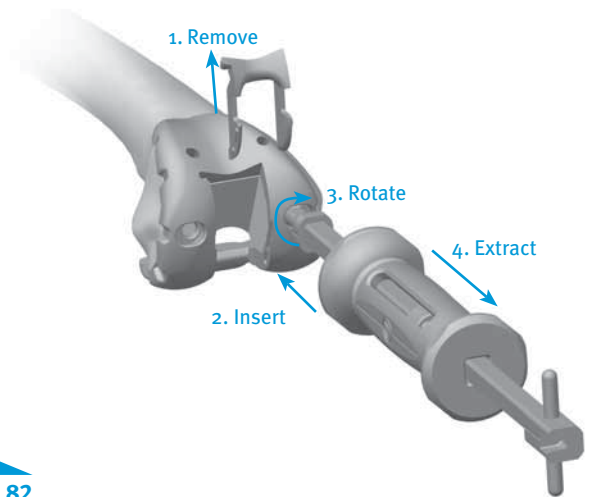

Fig. 82

Instruments



Perform Trial Reduction

- Remove any posterior osteophytes or overhanging bone on the femur to ensure maximum knee flexion. In this step, a trial reduction is performed to check component position, patellar tracking, range-of-motion (ROM), and joint stability. Depending on the order of the surgical steps, some of the provisional components may already be in place. For example if the Cemented Tibial Sizing Plate is to be used, it may already be in place. If the femoral provisional was the last bone preparation step, it will already be in place. If not, attach the Femoral Inserter/Extractor to the appropriate femoral provisional and insert on the bone in the correct position (Fig. 83a & 83b).

Fig. 83a



Fig. 83b



TECHNIQUE TIP

10.A

Be sure that soft tissue is not trapped beneath the provisionals. Impact until fully seated.

- Remove the Femoral Inserter/Extractor from the provisional. With the knee in extension, ensure that the provisional is flush against the resected distal surface of the femur on the medial condyle. Retract the lateral side and check to make sure it is flush distally, on the lateral side. If preparation for patella resurfacing has been performed, insert the appropriate patella provisional during the trialing phase.

Instruments

							
Quick Connect Handle 00-5901-034-00	Tibial Impactor Head 00-5901-033-00	Persona Stemmed Tibial Provisional Size F Right 42-5321-075-02	Persona Femoral Inserter/Extractor 42-5099-092-00	Persona Cemented Tibial Sizing Plate Size F Right 42-5399-075-02	Persona Femoral CR Impactor Pad 42-5099-094-00	Persona CR Femoral Provisional Size 7 Right 42-5027-062-02	Persona Femoral PS Impactor Pad 42-5099-093-00
							
Persona PS Box Provisional 6-9 Right 42-5007-060-12	Persona PS Femoral Provisional Size 7 Right 42-5007-062-02	Standard All-Poly Patella Provisional, Size 35mm x 9mm 00-5971-065-35	Tibial Provisional Extractor 00-5977-017-00				

Tibial Articular Surface Provisional (TASP) Assembly

- The TASP consists of 3 parts: a TASP bottom, a TASP shim, and a TASP top. Select the TASP bottom that matches the Cemented Tibial Sizing Plate or Tibial Baseplate implant. Select the TASP top that mates with both the TASP bottom and the femoral provisional or component as marked on the anterior face of the TASP top (**Fig 84a**). In addition to the markings on the parts, the same colors are used for the mating TASP tops and bottoms. Axially align the pin slots on the TASP top with the pins on the TASP bottom during assembly as these parts must be assembled BEFORE the TASP shim can be used (**Fig 84b**). Select the set of TASP shims that match the selected Tibial implant size.

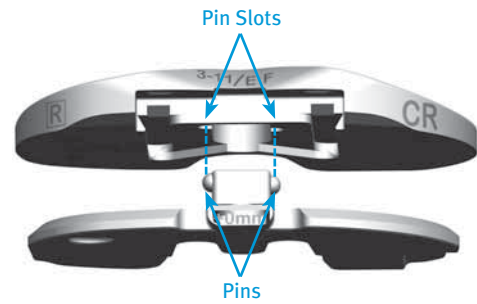

Fig. 84a



Fig. 84b

TECHNIQUE TIP

11.A

There are two TASP bottom thicknesses +0mm and +6mm. Use +0mm bottom for 10-14mm constructs and the +6mm bottom for 16-20mm constructs.

Note: TASP bottom pins are offset to prevent assembly of left TASP tops on right TASP bottoms and vice versa.

TECHNIQUE TIP

11.B

As shown on the anterior face of the TASP top, confirm the correct constraint, femoral compatibility, tibial size, and side.

TECHNIQUE TIP

11.C

Apply gentle manual pressure without impacting the TASP construct with either a mallet or hand. The TASP construct includes the TASP top, bottom, shim, and Tibial Sizing Plate Handle.

TECHNIQUE TIP

11.D

As described on page 13, if using the Cemented Tibial Sizing Plate during the trialing phase, please assure that the necessary male-headed screws/pins are removed from the anterior surface of the Cemented Tibial Sizing Plate to avoid interference and potential damage to the TASP.

Instruments



Persona TASP Top Right CR 3-11/EF
42-5270-005-10



Persona TASP Top Right Ultracongruent 4-11/EF
42-5272-005-10



Persona TASP Top Right PS 6-9/EF
42-5274-007-10



Persona TASP Right EF +0 Bottom
42-5270-005-05



Persona TASP Right EF +6 Bottom
42-5270-005-15

- The Shims (10, 11, 12, 13, and 14mm) are not side-specific. Attach the Tibial Sizing Plate Handle to the appropriate 10mm shim (Fig. 85a). While holding the TASP top and bottom together with one hand, lock the TASP top and bottom together by inserting the appropriate 10mm shim with the Tibial Sizing Plate Handle (Fig. 85b). The 10mm shim will create a TASP construct which matches the thickness of the thinnest tibial articular surface implant, 10mm (Fig. 86a & 86b).

TECHNIQUE TIP

11.E

During assembly of the TASP construct, slide the shim in using a direct anterior approach between the TASP top and bottom. To avoid inadvertent separation, maintain slight pressure between the TASP top and bottom while inserting the shim.

- The shims are incremented by 1mm to create TASP constructs of 10mm, 11mm, 12mm, 13mm or 14mm to match the implant offering. The +6mm bottoms are included for instances where the TASP construct needs to be 16mm, 18mm or 20mm. In these circumstances, the 10mm, 12mm, and 14mm shims are to be used to create the respective TASP constructs.

Note: The maximum thickness of available CR implants is 18mm. UC and PS implants are available in thicknesses up to 20mm. Also, 15mm, 17mm and 19mm thicknesses are NOT available in CR, UC, or PS

- It is recommended that the thinnest TASP construct (10mm) be inserted into the joint space, with the knee at greater than 30° of flexion (Fig. 87a), to perform an initial ROM assessment.
- If a thicker construct is needed to appropriately fill and balance the joint space, place the knee in approximately 5-15° of flexion (Fig. 87b) to facilitate in-vivo removal and insertion of the shims with the Tibial Sizing Plate Handle.

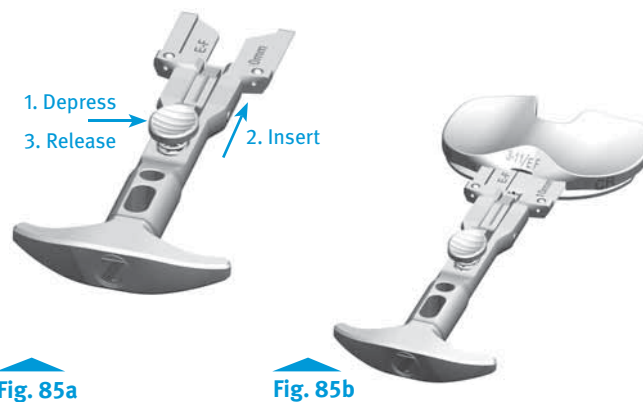

Fig. 85a

Fig. 85b



Fig. 86a



Fig. 86b

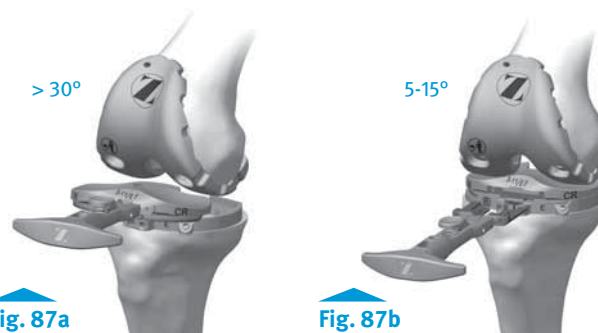

Fig. 87a

Fig. 87b

Instruments



Persona TASP
Right EF +6
Bottom
42-5270-005-15



Persona TASP
Top Right
Ultracongruent
4-11/EF
42-5272-005-10



Persona TASP Right
CR 3-11/EF
42-5270-005-10



Persona Tibial
Sizing Plate
Handle
42-5399-017-00



Persona TASP
Shim EF 10mm
42-5279-005-00

- The entire TASP construct can be removed to exchange the shims of the TASP construct. This is accomplished by flexing the knee greater than 30°, then lifting the Tibial Sizing Plate Handle while attached to the TASP construct. Once the anterior lip of the TASP bottom is above the anterior rail of the tibial sizing plate (Fig. 87c), rotate the TASP out of the joint space medially or laterally (Fig. 87d). This will aid in preventing unwanted shim disassembly during TASP removal.

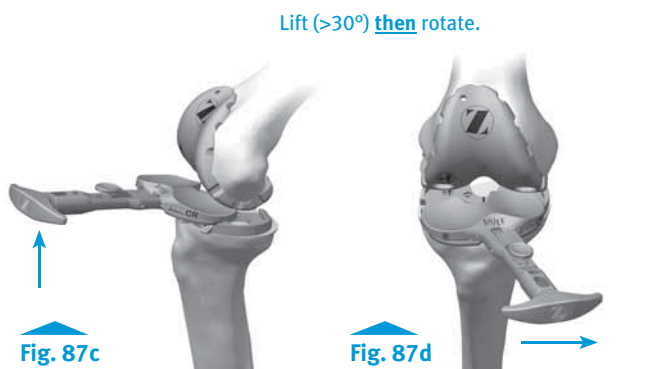

TECHNIQUE TIP

11.F

Varus/Valgus forces may make it difficult to remove the TASP construct. To aid in the removal of the TASP and prevent breakage, ensure that the joint is in a neutral position when removing the TASP construct.

- As shown (Fig. 88), size A and B tibias, size C and D tibias, size E and F tibias, and size G and H tibias, share side-specific tibial bottoms, tibial tops and color, respectively.
- When using the Stemmed Tibia Provisional: Assemble the Stemmed Tibia Provisional to the Tibial Provisional Extractor and insert in the prepared tibia bone. For additional fixation of the fully seated provisional, insert the 25mm x 3.2mm screw (2.5mm female hex) with the 2.5mm male hex driver through the 2 screw fixation holes in the medial and lateral compartments on the STP.

Note: Do NOT use 48mm screws for Cemented Tibial Sizing Plate fixation. 48mm screw are not recommended due to potential bone perforation.

TASP Shim/Construct Thickness

	10mm
	11mm
	12mm
	13mm
	14mm

Anterior divots in the shim correspond to the overall construct thickness as shown in the table above.

	Color Coded	Side Specific	Shared Sizing*
Tibial Sizing Plate	No	Yes	No
Articular Surface Tops	Yes	Yes	Yes
+0 Bottoms	Yes	Yes	Yes
+6 Bottoms	Yes	Yes	Yes
Shims	No	No	Yes

*Shared Sizing - A and B, C and D, E and F, G and H Cemented Tibial Sizing Plates have common TASP Tops, Bottoms and Shims respectively.

Fig. 88

Instruments



Persona TASP
Right EF +6
Bottom
42-5270-005-15



Persona TASP
Top Right
Ultracongruent
4-11/EF
42-5272-005-10



Persona TASP Top
Right CR 3-11/EF
42-5270-005-10



Persona Tibial
Sizing Plate
Handle
42-5399-017-00



Persona TASP
Shim EF 10mm
42-5279-005-00



Persona Stemmed
Tibial Provisional
Size F Right
42-5321-075-02



Tibial Provisional
Extractor
00-5977-017-00

- Check ligament stability in extension and in 30°, 60°, and 90° flexion. Attempt to distract the joint in flexion to ensure that it will not distract. If a posterior stabilized component is used, hyperflex the knee and verify that the spine still engages the cam. Insert the patellar provisional onto the resected patellar surface. Perform a ROM to check patellar tracking. When component position, ROM, and joint stability have been confirmed, remove all provisional components.
- If a CR femoral implant is to be used and the PCL is recessed or becomes deficient intraoperatively, the PCL should be fully resected and the Ultracongruent (UC) TASP should be trialed to assure desired ROM and joint stability prior to articular surface implant selection.
- If unacceptable Flexion/Extension gap imbalances exist, refer to the "Balance Flexion/Extension Gaps" section of Appendix B for potential options.
- The Constrained Posterior Stabilized (CPS) TASP may also be assessed if further stability is needed. Additional information for this product may be found in the Constrained Posterior Stabilized (CPS) Surgical Technique (97-5026-072-00). When greater varus/valgus constraint is needed and/or stems or augments are required, the surgeon should consider using a revision implant system.
- Assemble the Tibial Provisional Extractor to the Stemmed Tibia Provisional to remove the Stemmed Tibia Provisional prior to implanting the components.

TECHNIQUE TIP

11.G

If the TASP construct is used with the femoral and/or tibial implants, contact with bone cement should be avoided to prevent potential damage to the TASP components.

TECHNIQUE TIP

11.H

The Articular Surface Inserter should not be used with the TASP.

TECHNIQUE TIP

11.I

Use only the Tibial Sizing Plate Handle to remove the TASP construct. The use of other instruments may damage or break the TASP.

Instruments



Persona Tibial
Sizing Plate
Handle

42-5399-017-00

Implant Components

TECHNIQUE TIP

12.A

Prior to cementing implants remove provisionals and use pulse lavage to remove unwanted debris from the resected bone surfaces and the joint space.

- In this step, the final components are implanted, and the tibial articular surface is secured to the implanted tibial baseplate. When using cemented components, it is recommended to use two batches of cement. After the implants have been chosen, make a final check to ensure that all components are compatible. If the resected surfaces of the tibia and/or femur are sclerotic, drill multiple holes with a small drill (2.0mm-3.2mm) to improve cement intrusion. Mix the first batch of cement. The cement should have a doughy consistency when ready for use.

Tibial Plate

- Sublux the tibia anteriorly to allow adequate clearance to insert the tibial implant into the prepared bone. Do not apply substances other than bone cement to the tibial implant (i.e. do not dip implant into antibiotics or other substances). Keep the implant clean and free of debris prior to cementing. Place a layer of cement on the underside of the tibial baseplate, around the keel, on the resected tibial surface, and in the tibial IM canal. Assemble the Quick Connect Handle to the Tibial Impactor Head (Fig. 89). Unlock collar and hold, insert handle into impactor head, release collar, and rotate handle until “click” is heard. Position the tibial plate onto the tibia and use the Tibial Impactor to impact it until fully seated (Fig. 90). Thoroughly remove any excess cement in a consistent manner. Allow the cement to fully cure before performing a trial ROM or inserting the articular surface.

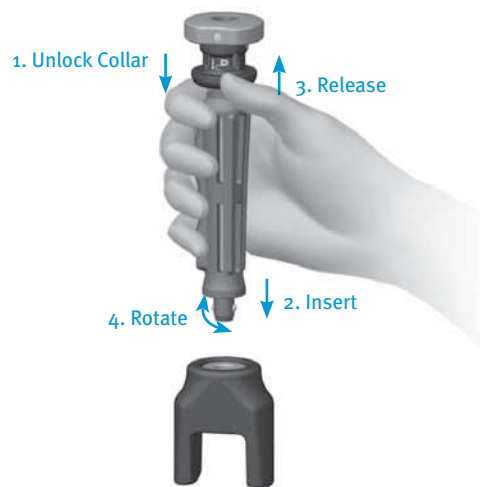

Fig. 89



Fig. 90

Instruments



Standard All-Poly
Patella Provisional,
Size 35mm x 9mm
00-5971-065-35



Quick Connect
Handle
00-5901-034-00



Tibial Impactor
Head
00-5901-033-00



Persona Cemented
Stemmed Tibial
Plate Sizes F Right
42-5320-075-02

Femoral Component

- With the knee in 70°-90° of flexion, retract the soft tissue in the desired manner. Place a layer of cement on the underside of the prosthesis and in the holes drilled in the femur. Attach the Femoral Inserter/Extractor to the femoral component (Fig. 91a & 91b). Insert the femoral component onto the distal femur by translating the component laterally until the lateral peg aligns with the drill hole in the lateral femoral condyle. Take care to avoid scratching the implant component surfaces. After the femoral component is placed on the femur and the Femoral Inserter/Extractor is removed, the Femoral Inserter/Extractor can be used to fully seat the implant onto the femur. If this method is used, the Femoral Inserter/Extractor handle must be in the closed and locked position. Ensure that soft tissue is not trapped beneath the implant. Alternatively, assemble the Quick Connect Handle to the Femoral Impactor Head (Fig. 92). Use this assembly to fully seat the femoral implant (Fig. 93). Remove retractors, and check the medial and lateral sides to make sure the femoral implant is fully impacted distally. Remove any excess cement in a thorough and consistent manner.

Articular Surface

- The Articular Surface Inserter applies both downward and rearward forces to aid in the insertion of the articular surface onto the tibial base plate. Choose the correct tibial articular surface based on size, side, constraint and thickness as determined by the trial range of motion. Place the articular surface onto the tibial base plate. Apply pressure anterior to posterior to properly engage the tibial component and tibial articular surface for final seating. This is necessary to allow the inserter to properly engage the tibial component and tibial articular surface for final seating. (Fig. 94). Steady the surface of the base plate with one hand by applying downward pressure near the posterior cruciate cutout. Engage the hook on the Articular Surface Inserter with the mating slot in the front of the base plate and close the lever with your index finger. This locks the inserter to the tibial plate (Fig 95a). Squeeze the handle of the Articular Surface Inserter to seat the articular surface (Fig. 95b). Open the lever and remove the Articular Surface Inserter.



Fig. 91a

Fig. 91b

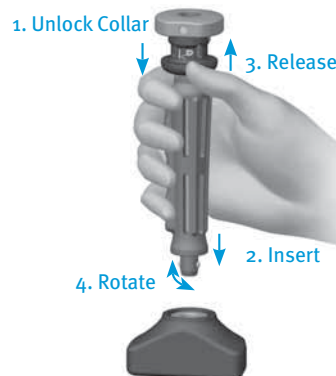

Fig. 92

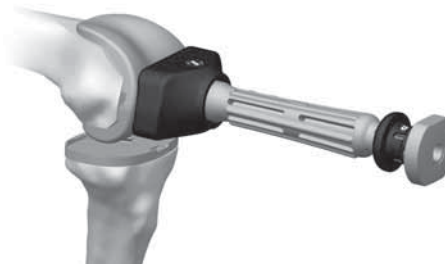

Fig. 93



Fig. 94

TECHNIQUE TIP

12.B

Insert an articular surface only once. Never reinsert the same articular surface onto a tibial base plate.

Instruments



Femoral Impactor Head
00-5901-032-00



Tibial Impactor Head
00-5901-033-00



Quick Connect Handle
00-5901-034-00



Persona Femoral Inserter/Extractor
42-5099-092-00



Persona Femoral PS Impactor Pad
42-5099-093-00



Persona Femoral CR Impactor Pad
42-5099-094-00



Persona CR Femoral Component
Size 7 Right
42-5026-062-02



Persona PS Femoral Component
Size 7 Right
42-5006-062-02

- Alternatively the articular surface can be locked into the tibial plate as described above, prior to tibial plate implantation. If PS implants are used, the femoral implant should be implanted before the tibial implant to avoid the excessive joint distraction required to clear the post while implanting the PS femoral implant. If CR implants are used, the tibial implant should be implanted prior to the femoral implant to facilitate the removal of excess cement from the posterior aspect of the tibia, prior to femoral implantation.

Fig. 95a

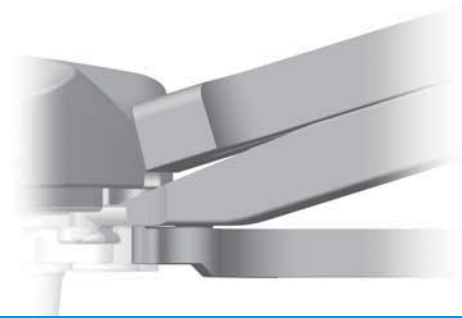

TECHNIQUE TIP

12.C

Only in-vivo assembly of the Ultracongruent articular surface is recommended because the design of the Ultracongruent articular surface precludes cement removal from the PCL cutout area at the tibial baseplate/bone interface.

- Assemble the Quick Connect Handle to the Tibial Impactor Head. Unlock collar and hold, insert Quick Connect Handle into Tibial Impactor Head, release collar, and rotate handle until “click” is heard. Position the tibial plate/articular surface construct onto the tibia and use the Tibial Impactor to impact it until fully seated (Fig. 96). Thoroughly remove any excess cement in a consistent manner.

Fig. 95b

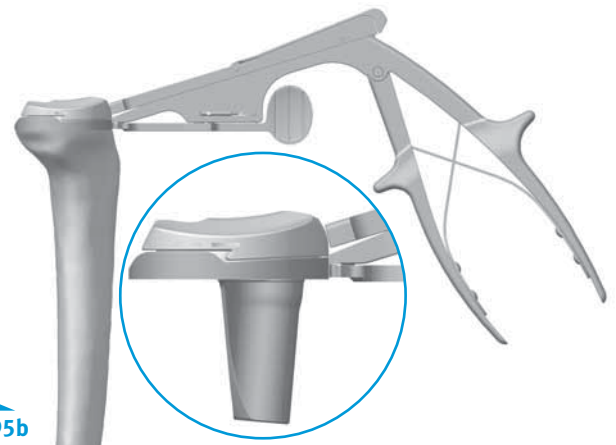

TECHNIQUE TIP

12.D

Do NOT impact or lever the Articular Surface Inserter or extractor tools when they are attached to the tibial plate as this may disrupt the fixation of the tibial plate to the bone and/or cause damage to the implant or instrument. Also, do not impact the articular surface.

- To remove an articular surface from the baseplate, engage the hook on the Articular Surface Removal Instrument with the mating slot on the front of the baseplate and squeeze the handle to disengage the articular surface from the baseplate. The Articular Surface Removal Instrument should not be used for provisional removal.

Fig. 96



Persona Stemmed Cemented Tibial Component
Size F Right
42-5320-075-02



Persona CR Tibial Articular Component
Size 3-11/EF Right
42-5210-005-10



Persona CR Ultracongruent Tibial Articular Component
Size 4-11/EF Right
42-5212-005-10



Persona PS Tibial Articular Component
Size 6-9/EF Right
42-5214-007-10



Persona Articular Surface Inserter
42-5299-001-00



Articular Surface Removal Instrument
00-5977-021-00

Patellar Component

Please refer to the appropriate surgical technique if other patella instrumentation is to be used to accomplish the patella implantation.

All-Polyethylene Patella

- With the knee in 70°-90° of flexion, apply cement to the anterior surface and pegs of the patellar component while in a doughy consistency. Alternatively, this step can be performed with the knee in full extension. Locate the drilled peg holes and use the Patella Clamp Assembly to insert and secure the patella in place. Fully open the jaws of the Patella Clamp and align the tooth to the anterior surface of the patella and the Patella Clamp Head to the posterior surface of the implant. (Fig. 97). Use the Patella Clamp to apply enough pressure to fully seat the implant on the patellar surface. Remove any excess cement in a thorough and consistent manner.



Fig. 97

Instruments



Patella Clamp
00-5903-020-00



Patella Clamp
Head
00-5903-021-00



Persona All-poly
Patella
Size 32mm
42-5400-000-32

Close Incision

- Freely irrigate the wound with the solution of choice to assure unwanted debris is removed from the joint space prior to closure. A drain may be placed intracapsularly. Then close the wound with sutures and apply a bandage. Please refer to package insert for complete product information, including contraindications, warnings, precautions and adverse effects.

Surgeon Notes & Tips

- Take care that the retractors do not inadvertently dislodge the tibial baseplate, particularly on the posterolateral corner. Verify that the femoral component is fully seated before closing the wound. Confirm that no portion of the quadriceps mechanism has been pinned beneath the femoral component.

2° Valgus Recut Guide

- Insert the Alignment Adapter into the tibial cut guide. Place the Alignment Rod with Coupler into the Alignment Adapter and assess the cut (Fig. 98). If a valgus correction cut is needed, place the Valgus Recut Guide on the resected tibial plateau, by attaching the Alignment Rod with Coupler and Alignment Adapter and aligning with the medial 1/3 of the tubercle. Once it has been determined that the desired correction cut will be attained, slide the medial portion of the Valgus Recut Guide so it is flush with the medial portion of the tibial cortex to provide a planar recut of the tibia. Affix with 3.2mm trocar-tipped pins with the Pin and Screw Inserter.

TECHNIQUE TIP

A.1

The fixation holes for the Valgus Recut Guide are at oblique angles to improve fixation of the guide.

- Perform resection, remove trocar-tipped pins and the Valgus Recut Guide (Fig. 99).



Fig. 98

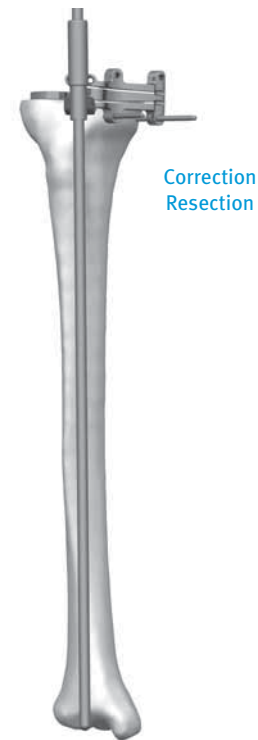

Fig. 99

Instruments



2° Varus Recut Guide

- Insert the Alignment Adapter into the tibial cut guide. Place the Alignment Rod with Coupler into the Alignment Adapter and assess the cut (**Fig. 100**). If a varus correction cut is needed, place the Varus Recut Guide on the resected tibial plateau, by attaching the Alignment Rod with Coupler and Alignment Adapter and aligning with the medial 1/3 of the tubercle. Once it has been determined that the desired correction cut will be attained, slide the lateral portion of the Varus Recut Guide so it is flush with the lateral portion of the tibial cortex to provide a planar recut of the tibia. Affix with 3.2mm trocar-tipped pins with the Pin and Screw Inserter.

TECHNIQUE TIP

A.2

The fixation holes for the Varus Recut Guide are at oblique angles to improve fixation of the guide.

- Perform resection, remove trocar-tipped pins and the Varus Recut Guide (**Fig. 101**).



Fig. 100



Fig. 101

Instruments



Pin/Screw Inserter
00-5901-021-00



75mm x 3.2mm Trocar Tipped Drill Pin (2.5mm hex)
00-5901-020-00



2° Varus Recut Guide
00-5901-090-01



Persona Tibial Cut Guide Right - 7°
42-5399-052-07



Alignment Rod with Coupler
00-5785-080-00



Persona Drop Rod Adapter
42-5399-006-00

Appendix B: Spacer Block Technique

TECHNIQUE TIP

B.1

The distal thickness of the Persona CR and PS femoral components is 9mm. The posterior thickness of the Persona CR component is 9mm and the posterior thickness of the Persona PS component is 10mm.

Check Extension Gap

- After the proximal tibia and distal femur have been resected, the extension gap can be evaluated using spacer blocks or a tensioning device. Position the knee in full extension. The distal thickness of the *Persona* femoral component is 9mm and the minimum *Persona* tibial articular surface/baseplate construct is 10mm. If a 10 spacer block (19mm thickness) does not fit into the resected joint space in extension, it will be necessary to remove additional bone from either the tibia or the femur. The spacer block physical thicknesses are 9mm more than what are shown on the spacer blocks to represent the combined *Persona* distal femoral thickness and the corresponding tibial component thickness.
- Use the Spacer/Alignment Guides or MIS Spacer/Alignment Guides to check the extension gap. Insert the thinnest appropriate Spacer/Alignment Guide between the resected surfaces of the femur and tibia (Fig. 102). If necessary, insert progressively thicker Spacer/Alignment Guides until the desired soft tissue tension is obtained. Drop the Alignment Rod with Coupler into the Spacer/Alignment Guide. Check the flatness, slope and alignment of the tibial cut. Apply varus and valgus stress for optimal ligament balancing. Ligament releases should be performed until the extension gap is rectangular. When the extension gap is balanced, proceed to size femur, establish external rotation and finish the femoral cuts.

Check Flexion Gap

- After the femoral finishing cuts have been completed and with the knee in 90° flexion, use the Spacer/Alignment Guides or MIS Spacer/Alignment Guides to check ligament balance and joint alignment in flexion. Insert the Alignment Rod with Coupler into the guide and check the alignment of the tibial resection (Fig. 103). Then check ligament balance. If necessary, insert progressively thicker spacer blocks until the desired soft tissue tension is obtained.



Fig. 102

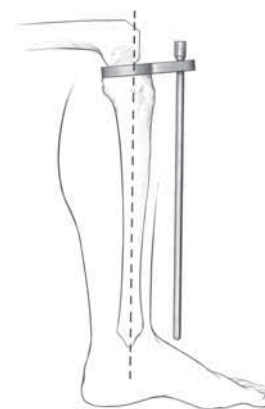

Fig. 103

Balance Flexion/Extension Gaps

TECHNIQUE TIP

B.2

Prior to addressing flexion/extension imbalances, make sure that desired varus/valgus alignment has been attained.

TECHNIQUE TIP

B.3

If femoral or tibial recuts are performed subsequent femoral finishing and tibial finishing steps need to be repeated to provide for proper provisional and component fit.

- With the knee in extension, attach the Alignment Rod to the Alignment Rod with Coupler. Check ligament balance and limb alignment in extension. Refer to the following chart (**Fig. 104**) for potential solutions for flexion/extension mismatches.
 1. If a knee is too tight in both flexion and extension, resecting additional tibial bone or reducing the height of the tibial articular surface may be sufficient to balance the construct.
 2. If the knee is tight in flexion but acceptable in extension, three options exist. One option is to release the PCL either by island osteotomy or ligament release, both of which lengthen the ligament. If the PCL is absent, change constraint to UC. A second option is to cement the femoral component distal to the bone cut. This augmentation with cement distally fills the extension space when used with a thinner tibial articulating surface. The third option is to downsize the femoral component.
 3. If the joint is loose in extension and tight in flexion one option is to use a smaller sized femoral component possibly with a thicker polyethylene component.
 4. If the joint is acceptable in flexion but tight in extension, several options exist. One is to release the posterior capsule from the femur. Another alternative is to resect more distal femoral bone. This moves the femoral component proximally on the femur at the expense of elevating the joint line.

		Extension		
		Tight	OK	Loose
Flexion	Tight	1	2	3
	OK	4	5	6
	Loose	7	8	9

Fig. 104

Instruments



Alignment Rod
with Coupler
00-5785-080-00



Alignment Rod
00-5785-079-00



MIS Spacer/
Alignment Guide
00-5983-070-10

5. If both components are acceptable, no further modification is necessary.
 6. If the joint is acceptable in flexion and loose in extension, consider downsizing the femoral component with a thicker tibial articular surface. If the femoral component cannot be downsized, cement the femoral component distal to the bone cut. This augmentation with cement distally fills the extension space.
 7. If the joint is loose in flexion and tight in extension, a larger femoral component may suffice. A second option is a thicker tibial articular surface with a more proximal femoral position. A third option is a thicker tibial component combined with a posterior release.
 8. If the joint is loose in flexion and acceptable in extension, increasing the femoral size may equalize the gaps. Alternatively, moving the femoral component proximally and applying a thicker tibial articular surface will equalize the gaps. Another option is to fill the flexion gap with the appropriate poly and perform a posterior release to increase the extension gap.
 9. If a joint is symmetrically loose in both flexion and extension, a thicker tibial articular surface will usually solve both problems.
- In situations where two options exist to help solve the soft tissue mismatch, the position of the patella or the joint line helps the surgeon decide which option to select.

Note: after applying one of these solutions, perform another trial reduction. This will identify any new problem or a variation of the initial problem that may exist.

		Extension		
		Tight	OK	Loose
Flexion	Tight	1	2	3
	OK	4	5	6
	Loose	7	8	9

Fig. 104

Appendix C: Optional Instruments: Resect Distal Femur - Fixed Distal Resection Instrument

Assemble Fixed Distal Resection Instrumentation

- Pull the lever on the Modular Handle and insert the IM Rod (Fig. 105). Orientation of the IM Rod will align with the polished line on the sides of the Modular Handle.

TECHNIQUE TIP

C.1

Alternately, the IM Rod may be inserted into the top of the Modular Handle to accommodate surgical preference.

- Insert the IM Rod into the Fixed Valgus Guide.

Note: If desired, align the depth markings on the IM Rod with the flat plate of the Fixed Valgus Guide to set the IM Rod at a specific length. (Fig. 106).

- Insert the Fixed Resection Tower into the face of the Fixed Valgus Guide indicating the angle and side of the knee (left or right).

Note: The valgus alignment guide will resect 10mm of distal bone. The distal resection can be changed to 1mm through 9mm resection depth, in 1mm increments, by assembling the corresponding Resection Plate to the Valgus Guide. Figure 107 illustrates this with the 9mm Resection Plate. The 9mm and 8mm Resection Plates may facilitate correction of a flexion contracture and the 1mm-3mm Resection Plates can be used for recutting the distal femur, if needed.



Fig. 105



Fig. 106



Fig. 107

Instruments



Persona
8mm IM Rod
42-5099-002-00



Persona
Modular Handle
42-5099-014-00



Persona
5° Valgus
Alignment Guide
42-5099-005-05



Persona
9mm Distal
Resection Plate
42-5099-015-09

- Rotate the lock lever on the Fixed Resection Tower to the unlocked, or “in-line”, position and fully insert into the Cut Guide (**Fig. 108a**).

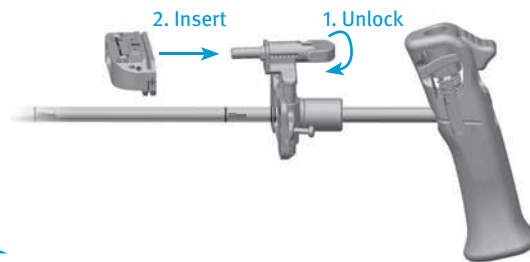

Fig. 108a

Flip the lock lever to the locked, or “vertical”, position to secure it to the Cut Guide (**Fig. 108b**).

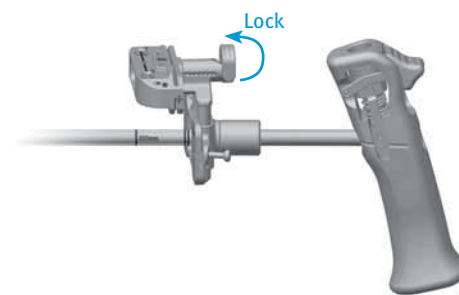

Fig. 108b

TECHNIQUE TIP

C.2

The Fixed Resection Tower is compatible with the Adjustable Valgus Guide and the Adjustable Resection Tower is compatible with the Fixed Valgus Guide. These instruments can be interchanged to accommodate surgical preference.

Instruments



Persona
8mm IM Rod
42-5099-002-00



Persona
Modular Handle
42-5099-014-00



Persona
5° Valgus
Alignment Guide
42-5099-005-05



Persona Fixed
Resection Tower
42-5099-006-00



Persona 0°
Distal Cut Guide
42-5099-010-00

Establish Femoral Alignment

- Drill the IM canal using the 8mm IM Step Drill (Fig. 109). Suction the canal to remove medullary contents.
- Insert the IM Rod and assembled distal resection instrumentation into the IM canal far enough to ensure the most accurate replication of the anatomic axis.

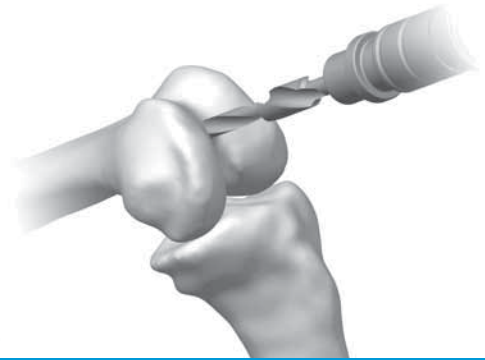

Fig. 109

- Set the orientation of the Fixed Valgus Guide by placing it against the most prominent distal condyle and rotating it about the IM Rod so that it is aligned with the epicondylar axis (Fig. 110).

Note: Setting rotation of the Fixed Valgus Guide is important for creating a distal resection that matches the desired valgus angle selected. It does not set the rotation of the femoral component.

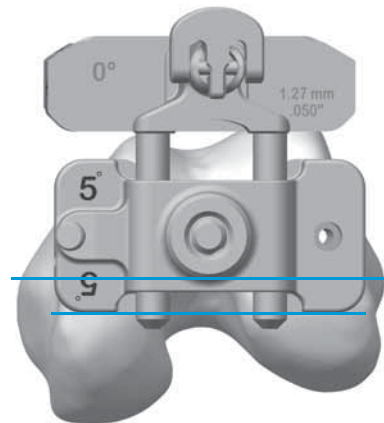

Fig. 110

- To secure orientation, impact the captured pin on the medial side of the Fixed Valgus Guide until the head of the captured pin is flush with the plate (Fig. 111).

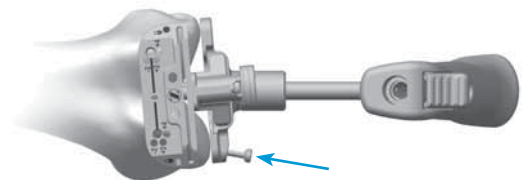

Fig. 111

Instruments



8mm IM
Step Drill
00-5978-014-00



Persona
8mm IM Rod
42-5099-002-00



Persona
Modular Handle
42-5099-014-00



Persona
5° Valgus
Alignment Guide
42-5099-005-05



Persona Fixed
Resection Tower
42-5099-006-00



Persona 0°
Distal Cut Guide
42-5099-010-00

Resect Distal Femur

- Verify the Fixed Valgus Guide is set to the proper side (left or right) and the Fixed Valgus Guide shows the appropriate valgus angle.

TECHNIQUE TIP

C.3

Confirm valgus alignment by inserting the Drop Rod Adapter into the large holes on the anterior face of the Cut Guide and insert an Alignment Rod into the Drop Rod Adapter (Fig. 112).

- Insert a Trocar Tipped Pin through each of the standard pin holes marked '0' on the anterior surface of the Cut Guide (Fig. 113).
- Flip the lock lever on the Fixed Resection Tower to the unlocked, or "in-line", position and pull the handle to remove the IM Rod and assembled distal resection instrumentation leaving only the Cut Guide attached to the femur (Fig. 114).

Note: If the captured pin was deployed it may be necessary to first remove it from the bone using the Pin Puller. Alternatively, removing the IM Rod from the Fixed Valgus Guide may facilitate removal of the captured pin from the bone.

TECHNIQUE TIP

C.4

Additional 2mm adjustments may be made by using the sets of holes marked -2, +2, and +4. These sets of holes indicate, in millimeters, the amount of additional bone resection each will yield relative to the 10mm resection accommodated by the Fixed Resection Tower (However, if the 9mm Resection Plate is used, the depth adjustments are relative to a 9mm resection).

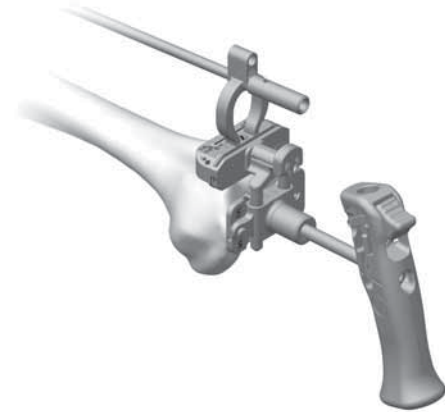

Fig. 112

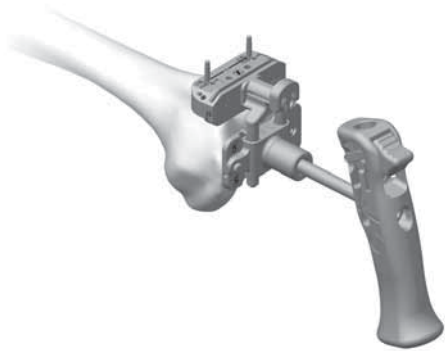

Fig. 113

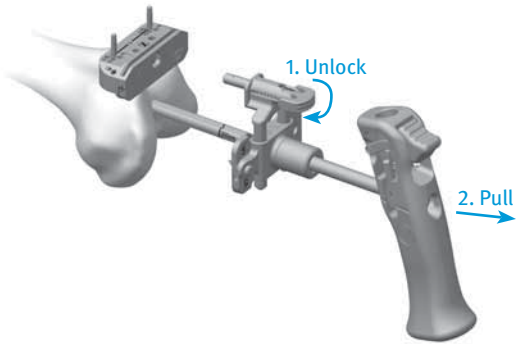

Fig. 114

Instruments



Persona
8mm IM Rod
42-5099-002-00



Persona
Modular Handle
42-5099-014-00



Persona
5° Valgus
Alignment Guide
42-5099-005-05



Persona Fixed
Resection Tower
42-5099-006-00



Persona 0°
Distal Cut Guide
42-5099-010-00



Persona Drop
Rod Adapter
42-5399-006-00



Alignment Rod
with Coupler
00-5785-080-00



3.2mm x 75mm
Trocar Tipped Drill
Pin (2.5mm hex)
00-5901-020-00



Pin/Screw
Inserter
00-5901-021-00

Appendix C: Optional Instruments: Shift Block

- Prior to performing the four facet cuts with the 4-in-1 Cut Guide, determine whether the position of the block anterior to posterior and external rotation is sufficient. If adjustment is needed, remove the 4-in-1 Cut Guide from the femur and insert the Shift Block using the same holes in the distal face of the femur (**Fig. 115**).

Fig. 115

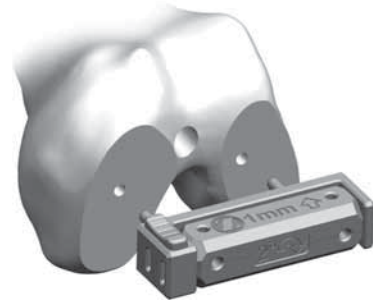

To select the method of adjustment, depress button and rotate drill guide until the desired face is shown. If a 2° rotation is desired, rotate the guide to the appropriate 2° rotation face (**Fig. 116**).

Fig. 116

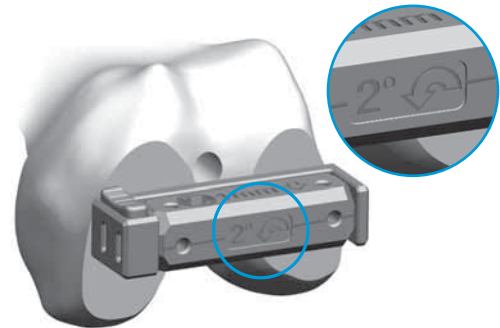

If an A/P shift is desired, rotate the guide to the appropriate 1mm shift face (**Fig. 117**).

Fig. 117

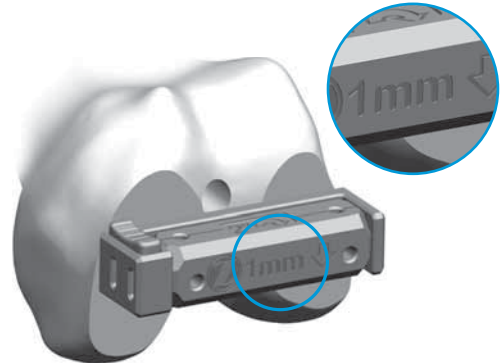

TECHNIQUE TIP

C.5

The Persona Shift Block is only to be used with the Persona 4-in-1 Cut Guides.

TECHNIQUE TIP

C.6

Do not impact or torque the Shift Block while inserting or drilling.

Instruments



Persona
Shift Block
42-5099-085-10



3.2mm Drill
00-5120-085-00

- After making sure the appropriate face is locked in place, drill through the holes that have been selected using a 3.2mm drill (**Fig. 118**).

TECHNIQUE TIP

C.7

Ensure drill guide is locked in place for accurate shift or rotations.

Fig. 118

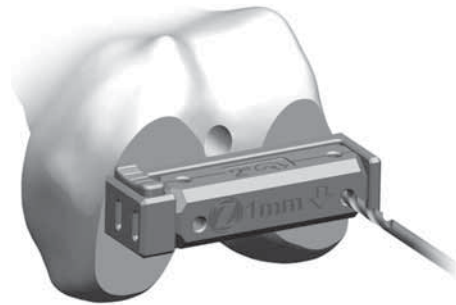

- If additional adjustment with the Shift Block is desired, remove it from the bone, using an osteotome if necessary, and replace it in the newly drilled holes and repeat the drilling process. Otherwise, place the 4-in-1 Cut Guide in the newly drilled holes (**Fig. 119**) and perform bone resections.

TECHNIQUE TIP

C.8

The Shift Block can be rotated 180° to create new drill holes in the opposite M/L direction while providing the same A/P shift or rotation adjustment. If a 180° rotation is performed, be careful to avoid overlapping previously drilled holes.

Fig. 119

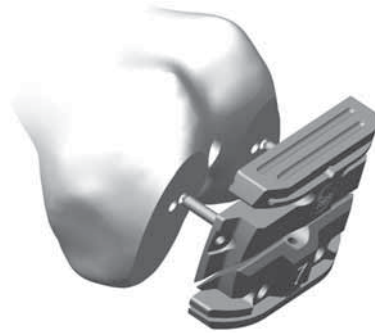

Instruments



Persona
Shift Block
42-5099-085-10



3.2mm Drill
00-5120-085-00



Persona Anterior
Referencing 4-in-1
Cut Guide - Size 7
42-5099-085-62

Appendix C: Optional Instruments: Resect Distal Femur - PRI Distal Resection Instrument

Please refer to the appropriate surgical technique if other distal femoral alignment and distal femoral resection instrumentation is to be used to accomplish the distal femoral resection.

- After attaining the desired soft tissue exposure, use the 8mm IM Step Drill to make a starter hole (Fig. 120).
- Suction the canal to remove medullary contents.



Fig. 120

- Insert the Femoral IM Rod into the Modular T-Handle (Fig. 121) and insert the IM-Rod into the femur far enough to ensure the most accurate replication of the anatomic axis, then remove the Modular T-Handle (Fig. 122).

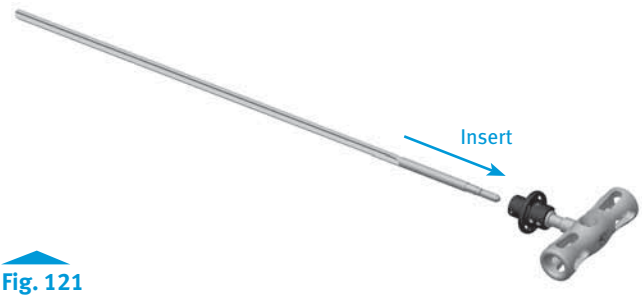

Fig. 121

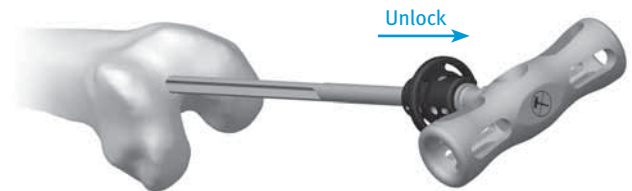

Fig. 122

TECHNIQUE TIP

C.9

As the symbol on the Modular T-Handle indicates – do not impact the Modular T-Handle.

Instruments



- Retract the spring-loaded button on the top of the Femoral Valgus Alignment Guide and rotate the valgus adjustment dial to the desired valgus angle and release the button to lock the valgus angle from 0° to 9°, ensuring that the proper left or right setting is attained (Fig. 123).

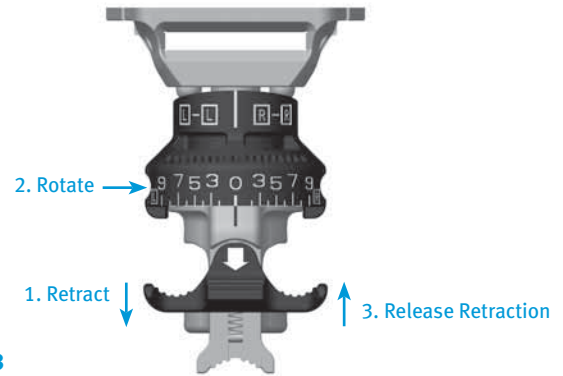

Fig. 123

- Place the Femoral Valgus Alignment Guide on the IM Rod against the most prominent condyle and confirm the desired valgus setting (Fig. 124).



Fig. 124

5° Right Valgus Setting

TECHNIQUE TIP

C.10

If the epicondyles are visible, the epicondylar axis may be used as a guide in setting the orientation of the Femoral Valgus Alignment Guide. This does not set the rotation of the femoral component, but keeps the distal cut oriented to the final component rotation. If desired, the guide can be pinned to provide rotational stability (Fig. 125).

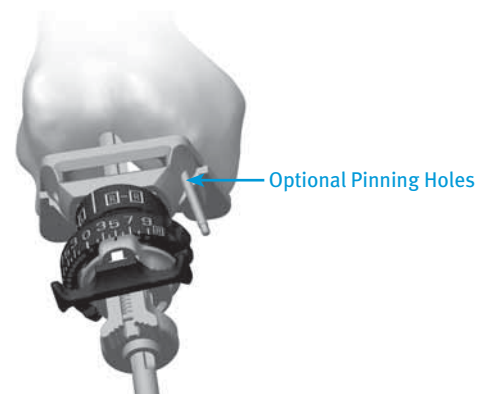

Fig. 125

Instruments



Femoral Valgus Alignment Guide
00-5901-067-00



3.2mm x 75mm Trocar Tipped Drill Pin (2.5mm hex)
00-5901-020-00



Pin/Screw Inserter
00-5901-021-00

Resect Distal Femur

- Attach the 0° Captured/Uncaptured Cutting Head to the Distal Femoral Distal Femoral Resection Guide (Fig. 126). The adjustment dial on the resection guide can be set from “-2” to “+4”. The “0” represents a 10mm distal resection (Fig. 127). The -1 setting represents a 9mm resection while the +4 setting represents a 14mm resection. Upon rotation, the dial has palpable stops and clear markings at each 2mm location. One half rotation creates 1mm of adjustment. Insert the Distal Femoral Resection Guide with the cutting head into the Femoral Valgus Alignment Guide until the cutting head rests on the anterior femoral cortex. Verify the desired resection setting on the Distal Femoral Resection Guide and/or rotate the adjustment dial to attain the desired setting. (Fig. 128a). Insert trocar-tipped pins through the two standard pin holes marked “0” on the anterior surface of the cutting head (Fig. 128b). Additional 2mm adjustments may be made by removing the cutting head from the pins and replacing the cutting head on the pins in the sets of holes marked -2, +2, and +4. The markings on the cutting head indicate, in millimeters, the amount of bone resection each will yield relative to the initial distal resection setting.

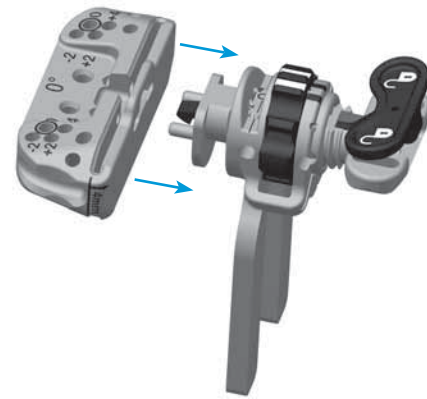

Fig. 126

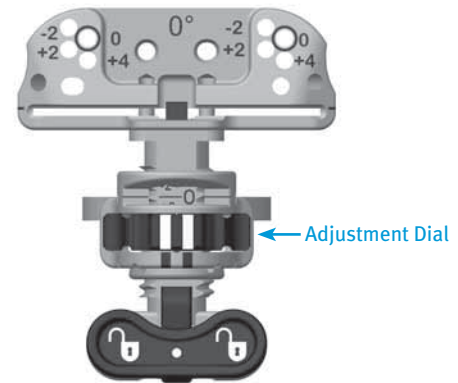

Fig. 127

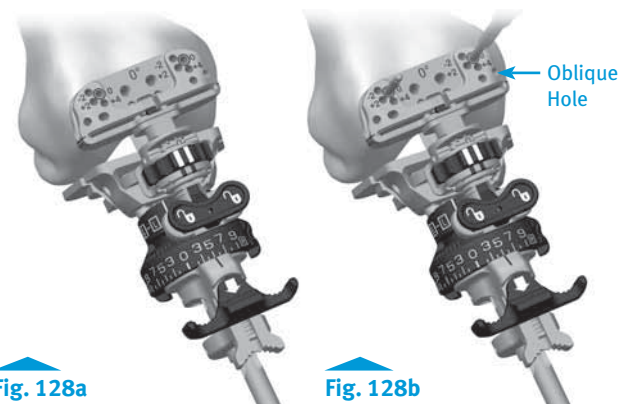

Fig. 128a

Fig. 128b

Instruments



Femoral Valgus Alignment Guide
00-5901-067-00



Distal Femoral Resection Guide
00-5901-063-00



0° Captured/Uncaptured Cutting Head
00-5901-064-00

TECHNIQUE TIP

C.11

If more fixation is desired, insert trocar-tipped pins in the small oblique holes on the cutting head.

- If pin(s) were used to maintain rotational alignment of the alignment guide, use the Multi Pin Puller to remove the pin(s). Alternatively, the Pin/Screw Inserter can be used to remove these pin(s).
- Squeeze the button on the Distal Femoral Resection Guide (Fig. 129) to release and remove the Femoral Valgus Alignment Guide and Distal Femoral Resection Guide assembly from the cutting head. The Modular T-Handle is used to remove the IM Rod, prior to the distal femoral resection.
- Alternatively, the Modular T-Handle can be used to remove the IM Rod while the button on the Distal Femoral Resection Guide is squeezed to facilitate rapid removal of the IM Rod, the Femoral Valgus Alignment Guide and the Distal Femoral Resection Guide at the same time. If necessary, the round end of the Slaphammer can be used in conjunction with the central hole in the Modular T-Handle to remove the IM Rod.
- Cut the distal femur through the cutting slot in the cutting head, using a 1.27mm (0.050 in.) oscillating saw blade (Fig. 130).

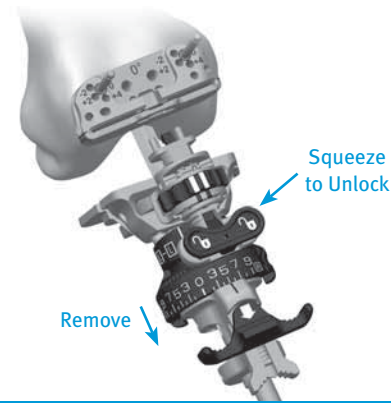

Fig. 129

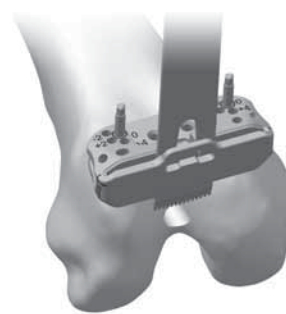

Fig. 130

TECHNIQUE TIP

C.12

Check the flatness of the distal femoral cut with a flat surface, such as the top of one of the Tibial Cut Guides. If necessary, modify the distal femoral surface so that it is completely flat. This is extremely important for the placement of subsequent guides and for proper fit of the implant.

- After completing the cut, remove pins and the cutting head.

Instruments



3.2mm x 75mm
Trocar Tipped Drill
Pin (2.5mm hex)
00-5901-020-00



Pin/Screw
Inserter
00-5901-021-00



Multi Pin Puller
00-5901-022-00



Persona
Slaphammer
42-5099-037-00



Femoral IM Rod
00-5901-060-00



Modular
T-Handle
00-5901-061-00

Appendix D: Compatibility Charts

Persona CR Femoral/Persona CR Articular Surface and Tibial Compatibility

CR		TASP Top and Bottom Color	Femoral Size												
			1	2	3	4	5	6	7	8	9	10	11	12	
Tibial Size	A	Orange	1-2 / AB		3-6 / AB										
	B														
	C	Yellow	1-2 / CD		3-9 / CD										
	D														
	E	Green			3-11 / EF										
	F														
	G	Blue							7-12 / GH						
	H														
	J	Gray									9-12 / J				

Persona CR Femoral/Persona UC Articular Surface and Tibial Compatibility

UC		TASP Top and Bottom Color	Femoral Size											
			1	2	3	4	5	6	7	8	9	10	11	12
Tibial Size	A	Orange	1-2 / AB		3-4 / AB									
	B													
	C	Yellow	1-2 / CD		3-7 / CD									
	D													
	E	Green			4-11 / EF									
	F													
	G	Blue							7-12 / GH					
	H													
	J	Gray									9-12 / J			

Persona PS Femoral/Persona PS Articular Surface and Tibial Compatibility

PS		TASP Top and Bottom Color	Femoral Size											
			1	2	3	4	5	6	7	8	9	10	11	12
Tibial Size	A	Orange	1-2 / AB		3-5 / AB									
	B													
	C	Yellow	1-2 / CD		3-5 / CD			6-9 / CD						
	D													
	E	Green			3-5 / EF			6-9 / EF			10-11 / EF			
	F													
	G	Blue						6-9 / GH			10-12 / GH			
	H													
	J	Gray										10-12 / J		

Persona PS Femoral/Persona Constrained Posterior Stabilized (CPS) Articular Surface and Tibial Compatibility

CPS		TASP Top and Bottom Color	Femoral Size											
			1	2	3	4	5	6	7	8	9	10	11	12
Tibial Size	A	Orange	1-2 / AB		3-5 / AB									
	B													
	C	Yellow	1-2 / CD		3-5 / CD			6-9 / CD						
	D													
	E	Green			3-5 / EF			6-9 / EF			10-11 / EF			
	F													
	G	Blue						6-9 / GH			10-12 / GH			
	H													
	J	Gray										10-12 / J		

Persona CR Femoral/NexGen CR/CR-Flex Articular Surface and Tibial Compatibility

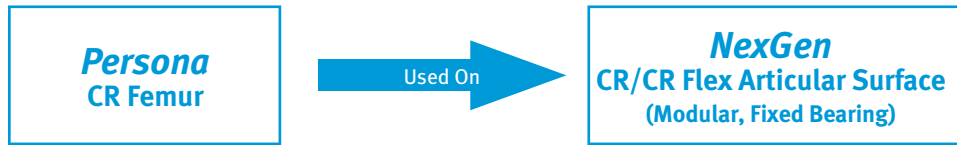

		Persona CR Femoral Size												
		1	2	3	4	5	6	7	8	9	10	11	12	
NexGen Tibial Size	1	A-E Micro / 1-2		C-H / 1-2										
	2													
	3	A-E Micro / 3-4		C-H / 3-4										
	4													
	5	A-E Micro / 5-6*		C-H / 5-6										
	6													
	7													
	8													
	9													
	10													

All compatibility above applies only to the following NexGen CR/CR-Flex articular surfaces:

90-5970-XXX-XX, 00/90-5952-XXXX-XX

*The A-E Micro / 5-6 NexGen CR/CR-Flex Articular Surface is only available in Japan, and only in the 00-5952-041-XX family.

This information is also available in the Persona femoral component package insert.

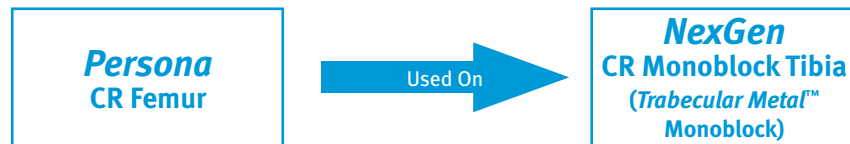

		Persona CR Femoral Size												
		1	2	3	4	5	6	7	8	9	10	11	12	
NexGen Tibial Size	1													
	2													
	3			C-H / 3										
	4			C-H / 4										
	5			C-H / 5										
	6			C-H / 6										
	7			C-H / 7										
	8			C-H / 8										
	9													
	10													

All compatibility above applies only to the following NexGen Trabecular Metal Monoblocks: 00-5886-04X-XX

This information is also available in the Persona femoral component package insert.

Persona PS Femoral/NexGen LPS-Flex Articular Surface and Tibial Compatibility

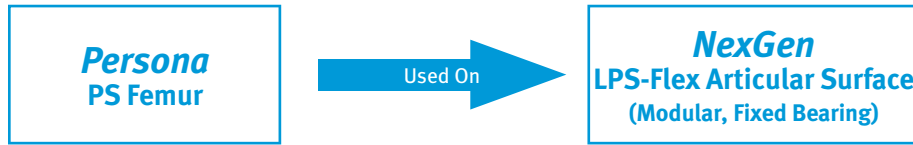

		Persona PS Femoral Size														
		1	2	3	4	5	6	7	8	9	10	11	12			
NexGen Tibial Size	1	AB / 1-2		CD / 1-2			E / 1-2*									
	2															
	3	AB / 3-4		CD / 3-4			EF / 3-4				G / 3-4*					
	4															
	5			CD / 5-6			EF / 5-6				GH / 5-6					
	6															
	7						EF / 7-10				GH / 7-10					
	8															
	9															
	10															

All compatibility above applies only to the following NexGen LPS-Flex articular surfaces:

00-5960-XXX-XX, 00-5962-XXX-XX, 00-5964-XXX-XX

*The E / 1-2 & G / 3-4 articular surfaces are only available in the 00-5962-XXX-XX family.

This information is also available in the Persona femoral component package insert.

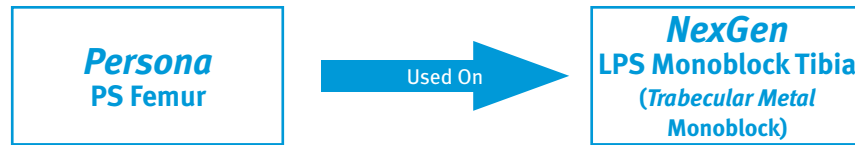

		Persona PS Femoral Size											
		1	2	3	4	5	6	7	8	9	10	11	12
NexGen Tibial Size	1												
	2												
	3			CD / 3			EF / 3						
	4			CD / 4			EF / 4						
	5			CD / 5			EF / 5			GH / 5			
	6						EF / 6			GH / 6			
	7						EF / 7			GH / 7			
	8										GH / 8		
	9												
	10												

All compatibility above applies only to the following *NexGen Trabecular Metal* Monoblocks:

00-5886-05X-XX, 00-5886-06X-XX, 00-5886-07X-XX

This information is also available in the *Persona* femoral component package insert.

Disclaimer

This documentation is intended exclusively for physicians and is not intended for laypersons. Information on the products and procedures contained in this document is of a general nature and does not represent and does not constitute medical advice or recommendations. Because this information does not purport to constitute any diagnostic or therapeutic statement with regard to any individual medical case, each patient must be examined and advised individually, and this document does not replace the need for such examination and/or advice in whole or in part. Please refer to the package inserts for important product information, including, but not limited to, contraindications, warnings, precautions, and adverse effects.

Contact your Zimmer representative or visit us at www.zimmer.com

