

# AxSOS 3<sup>®</sup> Titanium Tibia Locking Plate System

## Operative technique



# AxSOS 3 Titanium

## Tibia Locking Plate System - ORIF technique

### Contents

Introduction . . . . .	3
Indications, precautions and contraindications . . .	4
Operative technique . . . . .	6
Pre-operative planning . . . . .	6
Patient preparation . . . . .	7
Bending and non-locking screw fixation . . . . .	8
Locking screw fixation . . . . .	10
Proximal lateral tibia plate . . . . .	12
Proximal medial tibia plate . . . . .	21
Distal anterolateral and distal medial tibia plate . .	26
Additional tips . . . . .	32
SPS Titanium – AxSOS 3 Titanium compatibility chart . . . . .	33

This publication sets forth detailed recommended procedures for using Stryker devices and instruments. It offers guidance that you should heed, but, as with any such technical guide, each surgeon must consider the particular needs of each patient and make appropriate adjustments when and as required. A workshop training is recommended prior to first surgery. All non-sterile devices must be cleaned and sterilized before use. Follow the instructions provided in our reprocessing guide (OT-RG-1). Multi-component instruments must be disassembled for cleaning. Please refer to the corresponding assembly/disassembly instructions.

Please remember that the compatibility of different product systems has not been tested unless specified otherwise in the product labeling.

See instruction for use V15011, V15020, V15246 and V15013 for a complete list of potential adverse effects, contraindications, warnings and precautions.

The surgeon must discuss all relevant risks, including the finite lifetime of the device with the patient.

# Introduction

The AxSOS 3 Titanium Locking Plate System is intended for long bone fracture fixation. The system allows for the use of locking and non-locking screws in the metaphysis and the shaft.

Plates and Screws used in this Operative Technique Guide:

## AxSOS 3 Titanium 4.0mm anatomic shaped plates:

Proximal lateral tibia



Proximal medial tibia



## AxSOS 3 Titanium screws used with the AxSOS 3 Titanium 4.0mm anatomic shaped plates:

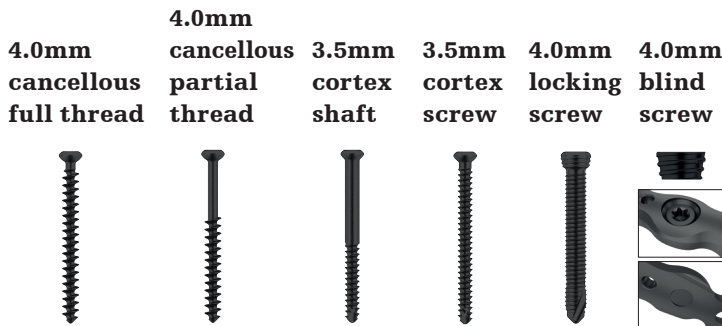

All of the above AxSOS 3 screws have a T15 screw head interface. Please refer to the compatibility table on page 33 showing SPS and AxSOS 3 Titanium compatibility.

## Material

Anodized type II titanium alloy (Ti6Al4V)

Cancellous Locking Cortical

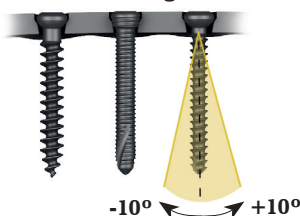

This operative technique contains a step-by-step procedure for the implantation of tibial plates using the ORIF instrumentation.

Distal medial tibia



Distal anterolateral tibia



## SPS titanium small fragment ISO screws used with the AxSOS 3 Titanium 4.0mm anatomic shaped plates:

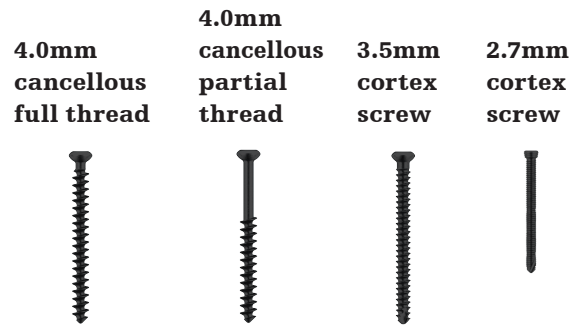

All of the above SPS titanium small fragment ISO screws have a Hex 2.5 screw head interface. Please refer to the compatibility table on page 33 showing SPS and AxSOS 3 Titanium compatibility.

## NOTICE

**2.7mm cortical screws are only used in the most distal holes of the Distal Anterolateral Tibia plate. For more information please refer to the specific sections of each plate type in this operative technique guide.**

# Indications, precautions and contraindications

## Indications

AxSOS 3 Titanium is intended for long bone fracture fixation. Indications include:

- Diaphyseal, metaphyseal, epiphyseal, extra- and intra-articular fractures
- Non-unions and malunions
- Normal and osteopenic bone
- Osteotomies
- Periprosthetic fractures of the femur and proximal tibia

The AxSOS 3 Titanium Waisted Compression plates are also indicated for fracture fixation of:

- Periprosthetic fractures
- Diaphyseal and metaphyseal areas of long bones in pediatric patients

The 4.0mm waisted compression plate indications also include fixation of the scapula and the pelvis.

## Precautions

### MRI Safety Information

#### AxSOS 3 Titanium System (no periprosthetic indication)

Non-clinical testing has demonstrated the Stryker AxSOS 3 Titanium System is MR Conditional. A patient with these devices can be safely scanned in an MR system meeting the following conditions:

- Static magnetic field of 1.5T and 3.0T
- Maximum spatial field gradient of 3000 gauss/cm (30T/m)
- Maximum MR system reported, whole body averaged specific absorption rate (SAR) of 2 W/kg (Normal Operating Mode)

Under the scan conditions defined above, the Stryker AxSOS 3 Titanium System is expected to produce a maximum temperature rise of less than 7.1°C after 15 minutes of continuous scanning.

In non-clinical testing, the image artifact caused by the device extends approximately 32mm from the Stryker AxSOS 3 Titanium System when imaged with a gradient echo pulse sequence and a 3.0T MRI system.

#### AxSOS 3 Titanium System (periprosthetic indication of the femur)

Non-clinical testing has demonstrated the Stryker AxSOS 3 Titanium System is MR conditional. A patient with these devices can be safely scanned in an MR system meeting the following conditions:

- Static magnetic field of 1.5T and 3.0T
- Maximum spatial field gradient of 2000 gauss/cm (20T/m)
- Maximum MR system reported, whole body averaged specific absorption rate (SAR) of 2 W/kg (Normal Operating Mode)
- Scan time restriction: maximum 6 minutes of continuous scanning
- Only in combination with MR conditional Stryker hip implants

Under the scan conditions defined above, the Stryker AxSOS 3 Titanium System is expected to produce a maximum temperature rise of less than 8.9°C after 6 minutes of continuous scanning.

In non-clinical testing, the image artifact caused by the device extends approximately 45mm from the Stryker AxSOS 3 Titanium System when imaged with a gradient echo pulse sequence and a 3.0T MRI system.

### CAUTION

**The MRI safety information provided is based on testing which did not include supplementary devices. If there are supplementary devices (i.e. plates, screws, wires, prosthesis etc.) present in proximity to the System, this could result in additional MRI effects and the information provided above may not apply.**

# Indications, precautions and contraindications

## ⚠ CAUTION

**AxSOS 3 Titanium 4.0mm and 5.0mm waisted compression plates should not cross the growth plates of pediatric patients.**

## Intended use

AxSOS 3 Titanium is intended for long bone fracture fixation.

## Contraindications

The physician's education, training and professional judgement must be relied upon to choose the most appropriate device and treatment.

Conditions presenting an increased risk of failure include:

- Any active or suspected latent infection or marked local inflammation in or about the affected area
- Compromised vascularity that would inhibit adequate blood supply to the fracture or the operative site
- Bone stock compromised by disease, infection or prior implantation that can not provide adequate support and/or fixation of the devices
- Material sensitivity, documented or suspected
- Obesity. An overweight or obese patient can produce loads on the implant that can lead to failure of the fixation of the device or to failure of the device itself
- Patients having inadequate tissue coverage over the operative site
- Implant utilization that would interfere with anatomical structures or physiological performance
- Any mental or neuromuscular disorder which would create an unacceptable risk of fixation failure or complications in post-operative care
- Other medical or surgical conditions which would preclude the potential benefit of surgery

Detailed information is included in the instructions for use attached to every implant. See instruction for use for a complete list of potential adverse effects and contraindications. The surgeon must discuss all relevant risks, including the finite lifetime of the device with the patient.

## NOTICE

**The only plates indicated for pediatric use are the 4.0mm and 5.0mm waisted compression plates.**

# Operative technique

## Pre-operative planning

Use of the X-ray template or E-templates can assist in the selection of an appropriately sized implant.

- Ref 981201 - proximal lateral tibia
- Ref 981202 - distal medial tibia
- Ref 981203 - distal anterolateral tibia
- Ref 981205 - proximal medial tibia

### NOTICE

**For conventional templates, the scale is 1:1.15 which usually matches with analogous X-rays. If digital X-ray images are used, correct magnification has to be verified prior to use.**

**AxSOS 3™ Titanium  
Titanium Locking Plate System  
Proximal Lateral Tibia Plate**

Scale: 1.15 : 1  
Magnification: 15%

**stryker®**

Osteosynthesis

**04.0mm Locking Screw, Self Tapping**  
REF 661014/-095

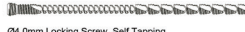

**03.5mm Cortex Screw, Self Tapping**  
REF 661414/-495



**04.0mm Cancellous Screw**  
Partial Thread: REF 607414/-495  
Full Thread: REF 607314/-395

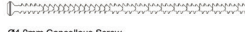



**A-P View**

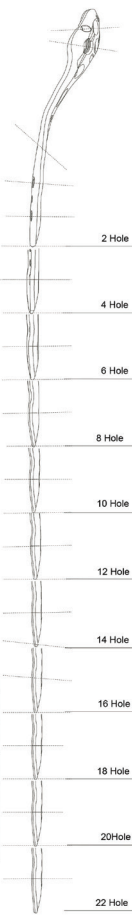

**M-L View**



**Please Note:**  
Due to the multi-planar positioning of the screw, the determination of the corresponding screw length and angle is difficult by means of single planar x-rays in general.  
All dimensions resulting from the use of this template have to be verified intraoperatively, to ensure proper implant selection.



Holes	REF
2	627302
4	627304
6	627306
8	627308
10	627310
12	627312
14	627314
16	627316
18	627318
20	627320
22	627322

Holes	REF
2	627302
4	627304
6	627306
8	627308
10	627310
12	627312
14	627314
16	627316
18	627318
20	627320
22	627322

Left Right

Left Right

Left Right

REF 981201 Rev.A

# Operative technique

## Patient preparation

### Patient positioning

Supine with option to flex the knee. Visualization of the proximal or distal tibia (depending on the indication) using fluoroscopy in both the lateral and AP views is necessary.

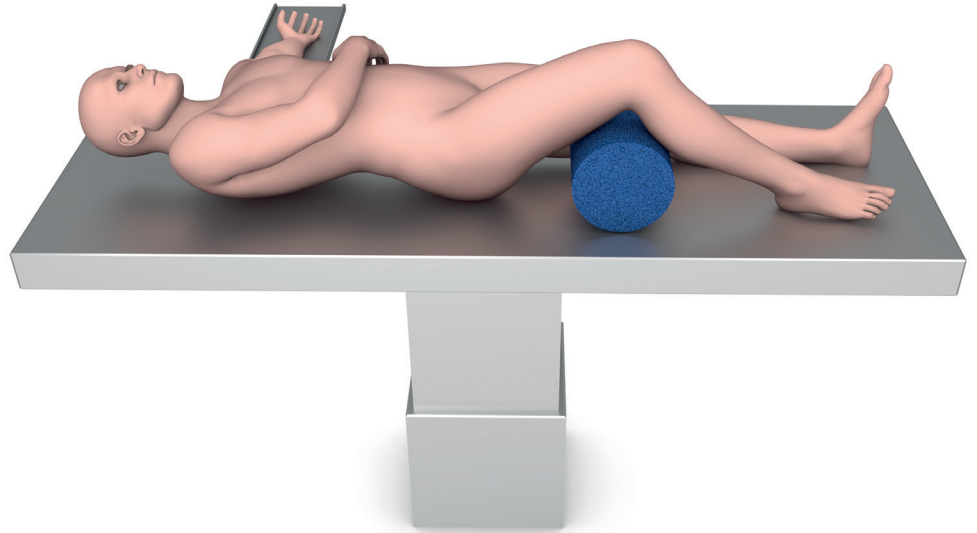

## Surgical approaches

### Proximal lateral tibia

Lateral parapatellar, lateral curved (hockey stick) or straight approach to the proximal tibia.

### Proximal medial tibia

Medial / posteromedial surgical approach to the proximal tibia.

### Distal medial tibia

Medial approach to the distal tibia.

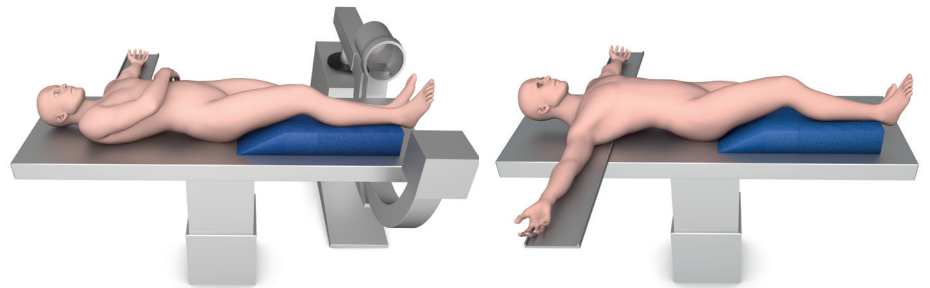

### Distal anterolateral tibia

Anterolateral approach to the distal tibia.

For a detailed explanation about the surgical approach please refer to the specific sections in this operative technique.

## Instrument / screw set

4.0mm AxSOS 3 Titanium ORIF instruments and screws set.

## Reduction

Anatomical reduction of the fracture should be performed

either by direct visualization with the help of percutaneous reduction clamps and/or K-wires or alternatively a bridging external fixator can aid indirect reduction.

For further detailed explanation about fracture reduction please refer to the specific sections in this operative technique.

If any large bony defects are present they should be filled by either bone graft or bone substitute material.

# Operative technique

## General information

### Bending

In most cases, the pre-contoured plate will fit without the need for further bending. However, should additional bending of the plate be required the bending irons type 1 and 2 (ref 705006 and 705007) or the table plate bender (ref 702900) should be used.

The bending irons are designed to be used as a pair. The holes allow the iron to be slid over the shaft of the plate for ease of bending. The open slots of the bending irons are designed to bend the thinner metaphyseal areas of the plate, if needed.

#### ⚠ CAUTION

**Bending of the plate in the region of the universal holes may affect the ability to correctly seat the locking screws into the plate and is therefore not permitted. Also do not overbend the plate and do not bend back and forth as this may weaken the plate.**

### Non-locking screw fixation

To seat a non-locking cortex or cancellous screw, take the drill guide for non-locking screws (ref 705022) together with the Ø2.5mm drill bit (ref 705025) and drill through both cortices for bi-cortical screw fixation (fig. 1).

The appropriate screw length can be determined as follows:

1. Directly read off the Ø2.5mm drill bit with the drill guide for non-locking screws or the double drill guide for cortical opening (fig. 2).
2. Use the depth gauge (ref 705012) (fig. 3).

Appropriately sized non-locking screws can be inserted into the plate using the T15 screwdriver (ref 705016).

If inserting non-locking screws under power using the T15 screwdriver bit (ref 705015), make sure to use a low speed drill setting to avoid potential thermal necrosis. In hard bone, it is advised to use the cortical tap Ø3.5mm (ref 702804) for cortex screws or the cancellous tap Ø4.0mm (ref 702805) for cancellous screws before screw insertion.



Fig. 1



Fig. 2



Fig. 3



# Operative technique

## General information

### Lag screw technique

To seat the 3.5mm non-locking cortex screw or a 3.5mm shaft screw in a lag function, use the dedicated double drill guide for cortical opening:

1. Over-drill the first cortex using the Ø3.5mm cortical opener (ref 700353) through the corresponding Ø3.5mm end of the double drill guide (ref 705023), (fig. 4).
2. Then insert the opposite Ø2.5mm end of the double drill guide (ref 705023) into the pre-drilled hole until the drill guide comes to a stop on the plate (insertion of about 15mm) (fig. 5).
3. Drill through the second cortex using the Ø2.5mm drill bit (ref 705025) (fig. 6). Remove the drill bit and drill guide.
4. Measure off the drill bit or by using the depth gauge as described above and insert the appropriate length cortical screw or shaft screw. As the threads will engage only in the far cortex, compression (lag) will be applied as soon as the screw head reaches the plate.

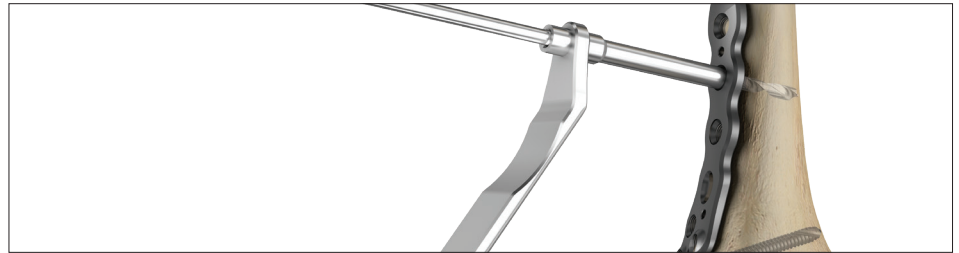

Fig. 4

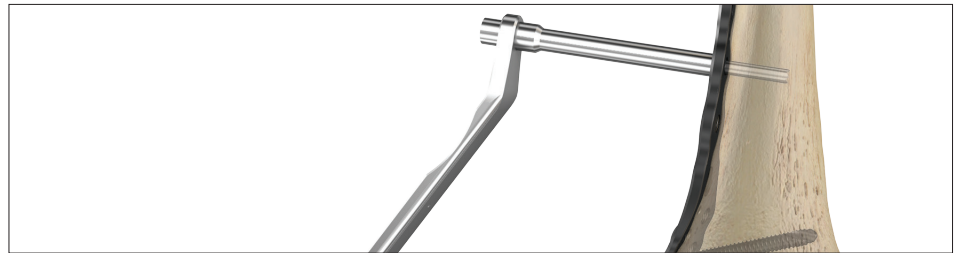

Fig. 5

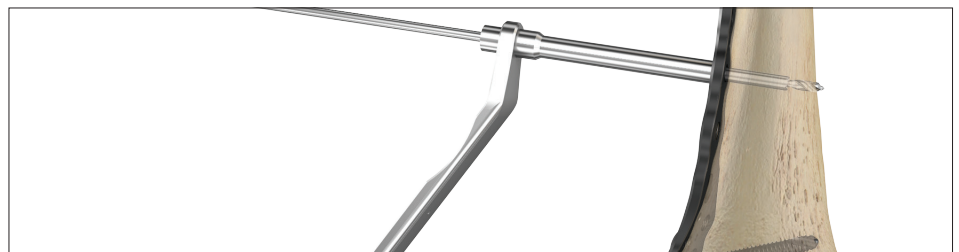

Fig. 6

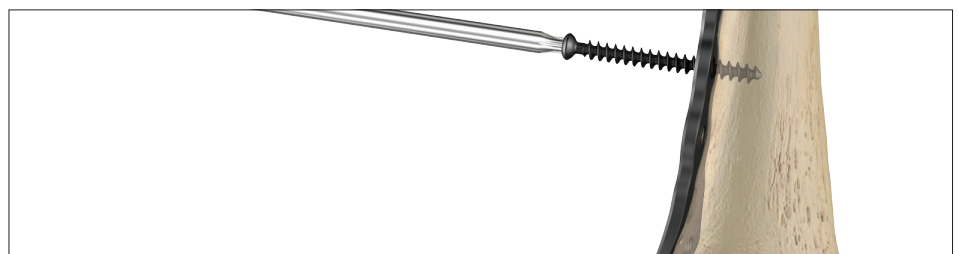

Fig. 7

### NOTICE

**Do not over-tighten as this might cause stripping of the threads in the bone and affect the construct stability (fig. 7).**

### Correct screw selection

Appropriate screw length selection is important for the stability of the fixation. Measurements follow the principle of "what you read is what you get".

This means that the measured value in millimeters on the depth gauge or the drill bit

is the exact value of the screw selected. In case a self-tapping screw is intended to be positioned bi-cortically, make sure the tip is slightly sticking out on the far cortex (1-3mm) in order to allow for good cortical purchase.

# Operative technique

## General information

### Locking screw fixation

To insert a locking screw - shown here as an example on a distal medial plate, always use the drill sleeve fully inserted into a universal hole. When working in the periarticular area, a drill sleeve may be inserted through the correct aiming block (fig. 8, 9).

### NOTICE

**If inserting the plate using the handle for plate insertion, place a drill sleeve after the aiming block is attached with the attachment screw to provide more stability (fig. 8).**

A Ø3.1mm drill bit (ref 705031 short or 705077 medium, depending on the short or medium sleeve chosen) is used to drill for Ø4.0mm locking screws (fig. 9). Medium size sleeves and drill bits show two orange color lines, short sleeves and drill bits show one orange line. The orange color represents the color code for the 4.0mm locking system. To ensure proper location and depth of the drill it is recommended to use multiple fluoroscopic views.

### Screw measurement

The appropriate screw length can be determined as follows:

1. Directly read off the drill bit with scale using (ref 705031 for short or 705077 for long drill) the appropriate drill sleeve (ref 705004 for short or 705075 for medium sleeve) (fig. 10).

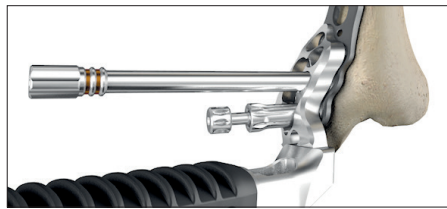

Fig. 8

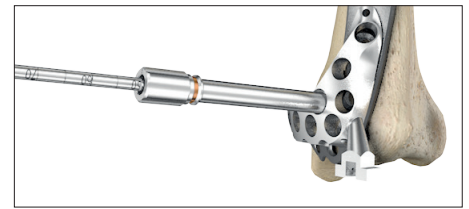

Fig. 9

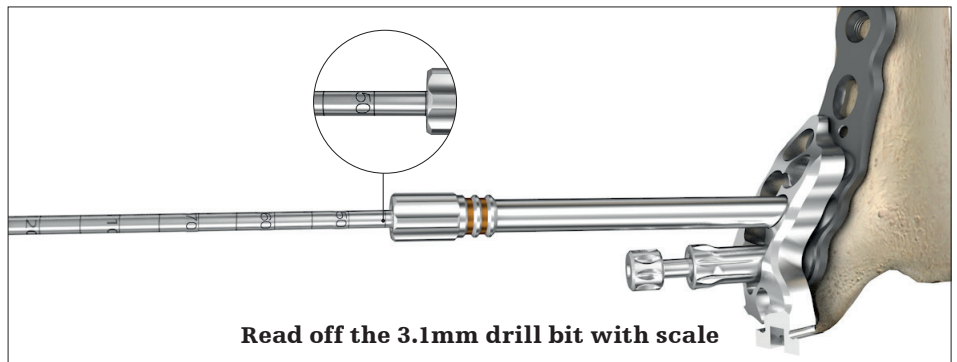

Fig. 10

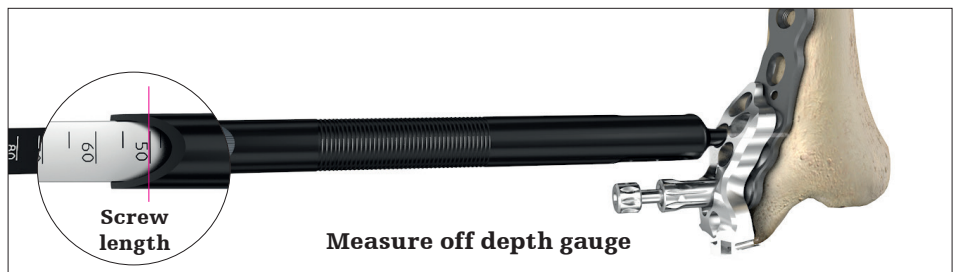

Fig. 11

2. Determine screw length by using the orange depth gauge (705012) (fig. 11).

### CAUTION

**When using the "read off the drill calibration" measurement option, always make sure to use drill and sleeve with corresponding number of color rings.**

### NOTICE

**Measuring with the depth gauge (705012) through the aiming block is not recommended in the most distal holes of the distal medial tibia plates as well as in the anterior and posterior most proximal holes of the proximal humerus plates (see separate operative technique guide) as the aiming block screw gets in conflict with the depth gauge and may result in wrong measurement.**

# Operative technique

## General information

### Locking screw fixation

#### Final locking with torque limiting attachment

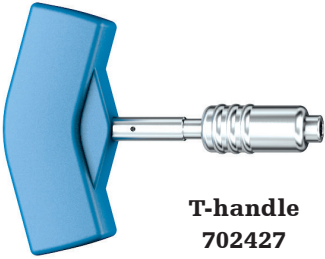

T-handle  
702427



2.5Nm Torque limiter  
702760



T15 screwdriver bit  
705015

#### T-handle assembly

Locking screws of appropriate length are inserted into the plate using the T15 screwdriver (ref 705016). If inserting locking screws under power using the T15 screwdriver bit (ref 705015), make sure to use a low speed drill setting to avoid damage to the screw plate interface and potential thermal necrosis. In hard bone, it is advised to use the locking tap Ø4.0mm (ref 702772) before screw insertion.

#### ⚠ CAUTION

Always perform final tightening of the locking screws by hand using the 2.5Nm torque limiter (ref 702760) together with the screwdriver bit T15 and T-handle. This prevents overtightening of locking screws and also ensures that these screws are properly tightened with a torque of 2.5Nm. The device will click when the torque reaches 2.5Nm. This procedure is repeated for all locking screws.

#### NOTICE

Ensure that the screwdriver tip is fully seated in the screw head, but do not apply axial force during final tightening. In the extreme event of broken or stripped screws, the Stryker implant extraction set (literature number IES-ST-1) includes a variety of broken screw removal instruments.

#### ⚠ CAUTION

The torque limiters require routine maintenance. Refer to the instructions for maintenance of torque limiters (V15020).



## Operative technique

### Proximal lateral tibia plate

Surgeons may use the lateral parapatellar, lateral curved (hockey stick) or straight approach to the proximal tibia, depending on the fracture pattern (surgical exposures in orthopaedics, the anatomic approach, 4th ed., hoppenfield et al).

#### Patient position

Place the patient supine on a radiolucent table to allow fluoroscopic imaging in both the AP and lateral views (fig. 12). Position a bump under the ipsilateral hip to correct natural external rotation of the extremity. Use a ramp or leg elevator to position the operative leg above the contralateral leg for lateral X-rays. Prepare the leg circumferentially to the mid-thigh to allow for proximal extension of the incision, allowing adequate exposure if an arthrotomy is required.

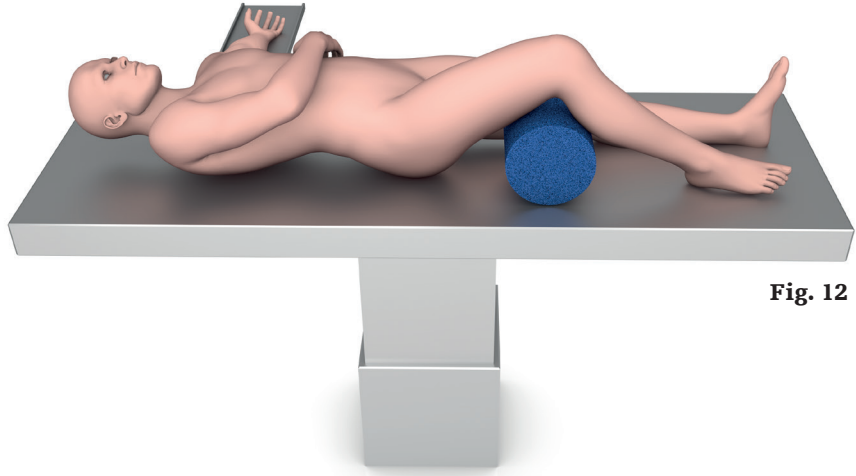

Fig. 12

# Operative technique

## Proximal lateral tibia plate

### Surgical approach

The anterolateral incision is curvilinear centered on Gerdy's tubercle, extending proximally to a direct lateral position at the knee. Incise the band in the same manner and perform a submeniscal arthrotomy if needed to confirm articular surface reduction. Elevate the muscles off the proximal tibia posteriorly to the fibular head.

After reduction is obtained, apply the plate to the anterolateral surface of the tibia. Prior to inserting any wires or screw fixation, confirm that the plate is under the iliotibial band and that the iliotibial band is not trapped under the plate, which would hinder future closure of this tissue layer.

In addition, apply the plate so that the lateral condyle is supported, with the proximal end of the plate approximately 5mm–10mm below the articular surface. This helps to ensure that the most proximal locking screws are directly supporting the joint surface.

In most cases, the pre-contoured plate will fit without the need for further bending.

However, should additional bending of the plate be required the table plate bender (ref 702900) should be used.

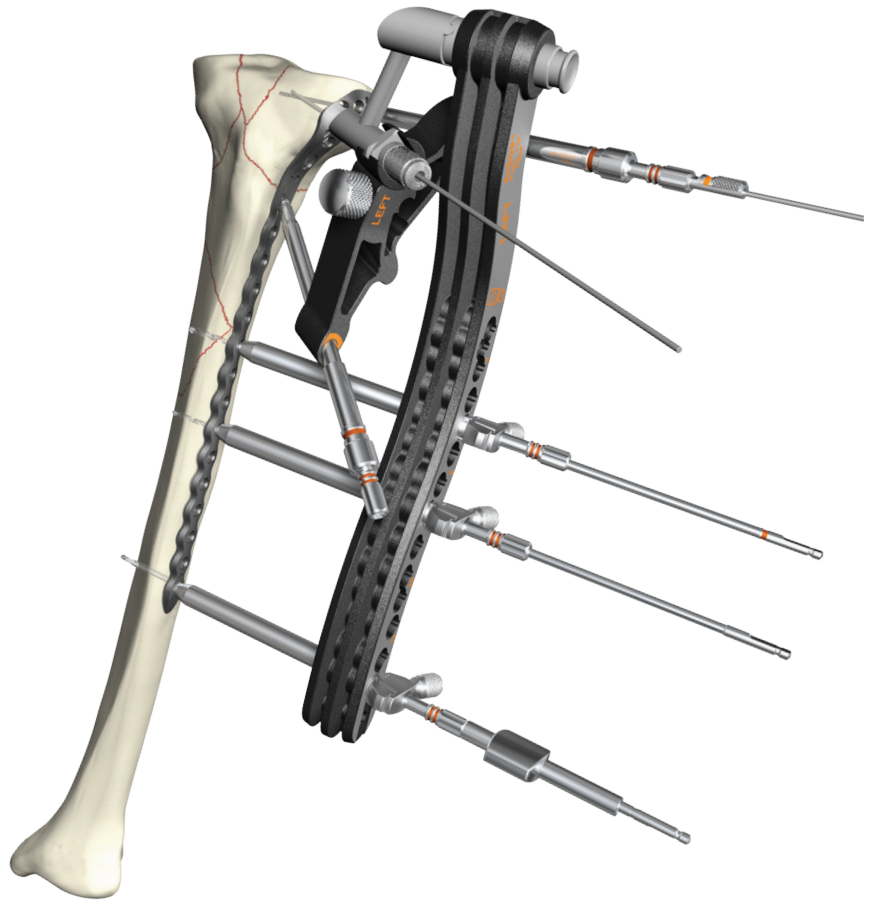

### NOTICE

**Proximal lateral tibia plates of the AxSOS 3 Titanium System can be inserted in a minimally invasive technique with targeting instrumentation. For detailed information please refer to the specific targeting operative technique available from your Stryker representative.**

# Operative technique

## Proximal lateral tibia plate

### Articular reduction

Anatomical reduction of the fracture should be performed either by direct visualization with the help of percutaneous reduction clamps (refer to the Stryker reduction instrument system literature number LTRB) (fig. 14) or K-wires or alternatively by using a bridging external fixator. Fracture reduction of the articular surface should be confirmed by direct vision, or fluoroscopy. Use K-wires as necessary to temporarily secure the reduction (fig. 13, 14).

Typically, K-wires set parallel to the joint axis will not only act to hold and support the reduction, but also help to visualize/identify the joint line. Care must be taken that these do not interfere with the required plate and screw positions.

Consideration must also be taken when positioning independent lag screws prior to plate placement to ensure that they do not interfere with the planned plate location or locking screw trajectories.

If any large bony defects are present, they should be filled by either bone graft or bone substitute material.

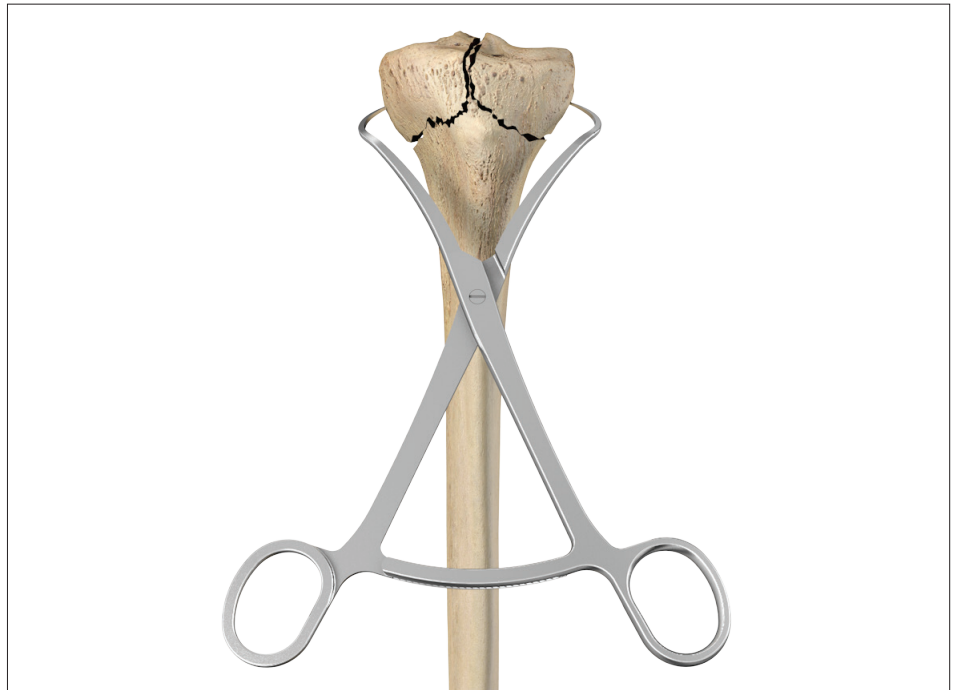

Fig. 13

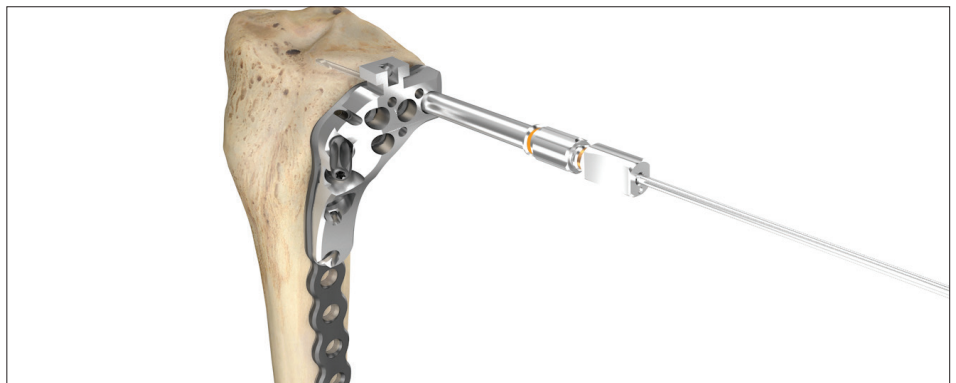

Fig. 14

# Operative technique

## Proximal lateral tibia plate

### Plate insertion

In order to help facilitate drill sleeve insertion as well as plate handle attachment to the plate, the aiming block may be used. Attach the correct aiming block (ref 705066 aiming block for proximal lateral tibia, left; ref 705065 aiming block for proximal lateral tibia, right) (fig. 15, 16) to the plate using the attachment screw by hand. The T15 screwdriver (ref 705016) might serve for aiming block removal in a later stage of the operation. If desired, the handle for plate insertion (ref 702778) can now be attached to the aiming block in order to help facilitate plate positioning and sliding of longer plates sub-muscularly (fig. 17).

Prior to plate insertion, the soft tissue elevator (ref 705782) can be used to prepare the plate pathway next to the periosteal tissue. After skin incision and anatomical reduction is achieved, apply and manipulate the plate until optimal position in relation to the joint is achieved.

This helps to ensure that the metaphyseal locking screws are directly supporting the joint surface.



Fig. 15

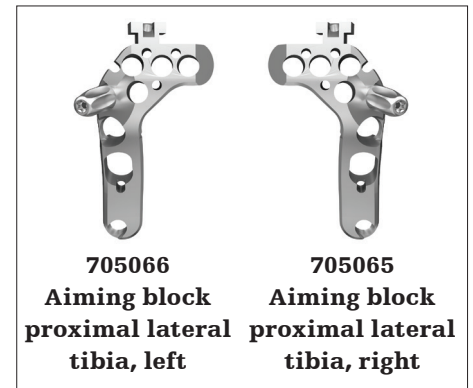

Fig. 16



Fig. 17

### Soft tissue

Special undercuts (fig. 18) on the reverse side of the plate correlating to the two proximal K-wire holes allow simple passing of sutures for meniscus reattachment. It is recommended to insert the sutures as soon as the plate is provisionally fixed to the bone but before the plate is finally locked or potentially compressed against the bone.



Fig. 18

# Operative technique

## Proximal lateral tibia plate

### Primary plate fixation proximal

The K-wire hole just distal to the oblong hole allows for temporary plate fixation in the metaphysis (fig. 20, 21).

Using the K-wire sleeve (ref 705003) in conjunction with the drill sleeve (ref 705004 or 705075), a 2.0 x 234mm K-wire (ref 705002) can then be inserted into the most posterior locking screw hole (fig. 20). This step shows the position of a posterior screw and its relation to the joint surface. It allows the confirmation that the screw will not be placed intra-articularly or too posteriorly exiting the cortex into the popliteal space. Using fluoroscopy, the position of this K-wire can be checked until the optimal position is achieved (fig. 20). Correct distal placement should also be re-confirmed at this point to make sure the plate shaft is properly aligned over the lateral surface of the tibial shaft (fig. 21). If the proximal and axial alignment of the plate cannot be achieved, the K-wires should be removed, the plate re-adjusted, and the above procedure repeated until both the posterior K-wire and the plate are in the desired position. Additional 2.0 x 150mm (ref 390192) K-wires can be inserted in the K-wire holes superior to the universal holes to further help secure the plate to the bone and also support depressed areas in fragments of the articular surface.

### NOTICE

**Do not remove the drill sleeve and K-wire sleeve at this point as it will cause a loss of the plate position.**

Remove the handle for plate insertion by pushing the metal lever on top of the handle (fig. 22).

Non-locking screws of appropriate length can now be inserted in the oblong hole of the plate as described in the "general guidelines" section.

Any K-wires in the shaft can be removed upon adequate screw fixation.

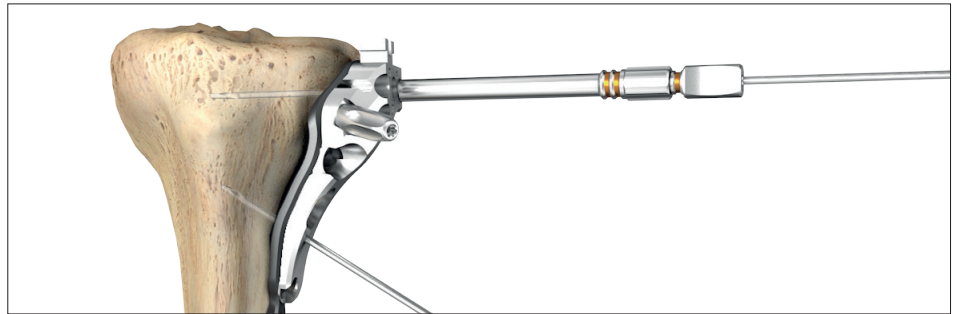

Fig. 20



Fig. 21



Fig. 19

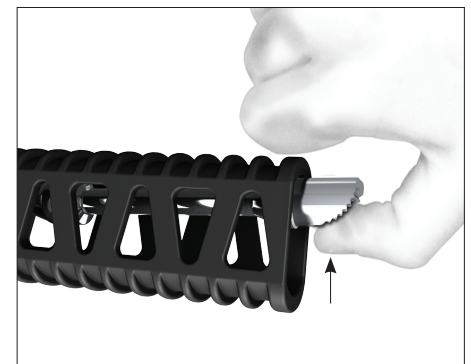

Fig. 22



# Operative technique

## Proximal lateral tibia plate

### Primary plate fixation – distal (optional)

The distal end of the plate can now be secured. This can be achieved through one of four methods:

- A K-wire inserted in a K-wire hole (fig. 23)
- A 3.5mm cortex screw using the standard technique
- A K-wire can be inserted in a universal hole through the K-wire/drill sleeve assembly
- The temporary plate fixator (ref 705019) in a universal hole in addition to providing temporary fixation, the temporary plate fixator pushes the plate to the bone. Also, it has a self-drilling, self-tapping tip for quick insertion into cortical bone

In order to protect surrounding soft tissues during pin insertion, the temporary plate fixator sleeve must be pre-assembled onto the temporary plate fixator pin with the self-drilling tip of the pin being flush with the tip of the sleeve (fig. 24).

The insertion of the temporary plate fixator pin must be done through the sleeve to prevent tissue damage, especially when used in a MIPO approach (fig. 25, 26).

To help prevent thermal necrosis during the drilling stage, it is recommended that the temporary plate fixator pin is inserted by hand.



Fig. 23

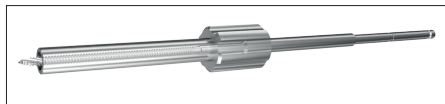

Fig. 24



Fig. 25

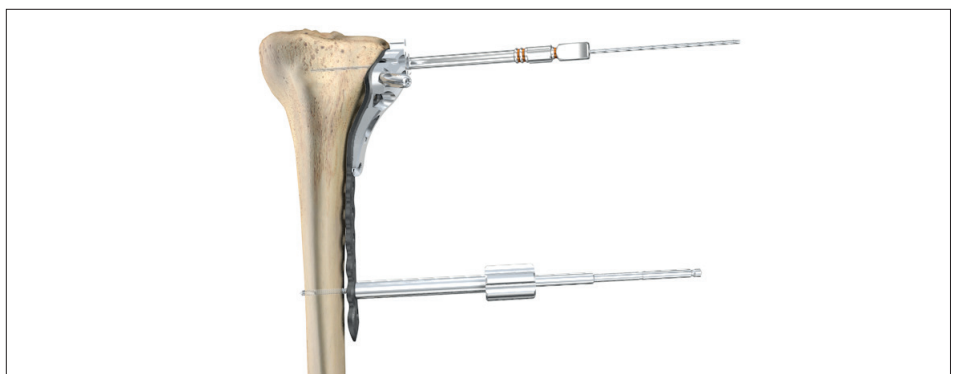

Fig. 26

## Operative technique

### Proximal lateral tibia plate

Once the device is inserted through the far cortex, the threaded outer sleeve resting on the plate is turned clockwise until the plate is in contact with the bone (fig. 27).

Replacing the temporary plate fixator with locking or non-locking screws for definitive fixation should is not recommended as proper alignment of the temporary plate fixator pin may not be guaranteed.

If placing a screw is required for final fixation, pre-drilling the hole using the appropriate drill guide as described by the following cortex, cancellous, and locking screw fixation guidelines is required.

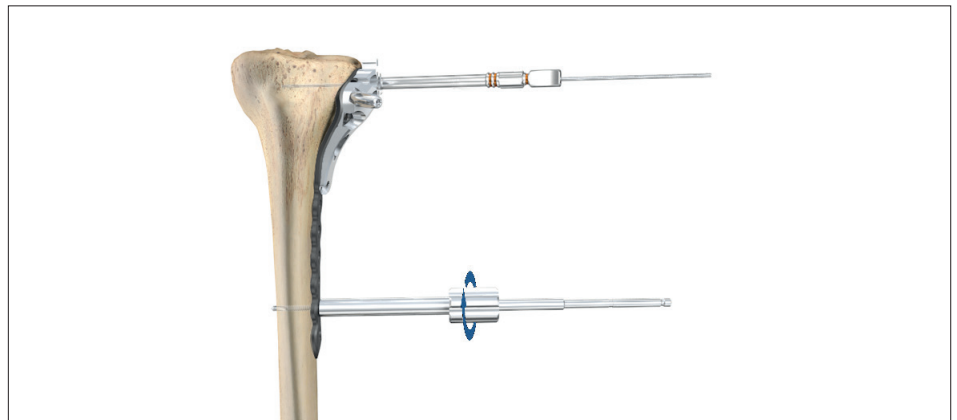

Fig. 27

# Operative technique

## Proximal lateral tibia plate

### Metaphyseal fixation

Locking screws cannot act as lag screws. Should an interfragmentary compression effect be required, a 4.0mm cancellous screw must first be placed in the plate prior to the placement of any locking screws – (following the "lag before lock" principle as described in the "General Guidelines" section).

Measure the length for the non-locking screw using the depth gauge (ref 705012), or by reading off the drill bit. Pre-tap the near cortex with the tap (ref 702804) if a 4.0mm cancellous screw is used. Consideration must also be taken when positioning this screw to ensure that it does not interfere with the given locking screw trajectories.

Fixation of the metaphyseal portion of the plate with locking screws can be started using the preset K-wire in the posterior locking hole as described above in the locking screw fixation section (fig. 29).

It is recommended to use multiple fluoroscopic views which may be necessary to ensure proper location and depth of the drill and measure the length of the screw using the Depth Gauge (ref 705012).

### ⚠ WARNING

**Care should be taken to ensure that there is no intra-articular penetration of metaphyseal screws.**

### NOTICE

**The threaded targeter attachment hole is for the exclusive use of connecting pin (ref 702974) from the AxSOS tibia targeter instrument set and the aiming block set screw. No other screws shall ever be placed in this hole. The two holes distal to the threaded targeter attachment hole accept non-locking screws only (fig. 28).**



Fig. 28

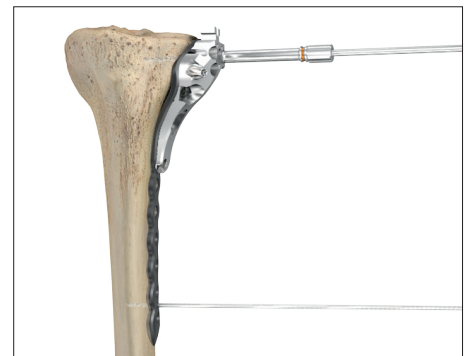

Fig. 29

## Operative technique

### Proximal lateral tibia plate

#### Kick-stand screw placement

The oblique "kick-stand" locking screw (fig. 30) provides strong triangular fixation to the postero-medial metaphyseal fragment.

It should be the last screw to be placed in the metaphyseal portion of the plate.

#### **⚠ WARNING**

**Make use of fluoroscopy while placing this screw to prevent joint penetration and impingement with the proximal screws.**

**The aiming block should now be removed. The distal universal holes now can be filled either with non-locking or locking screws - following the "lag before lock principle" as described in the "general guidelines" section.**

**All provisional plate fixation devices (K-wires, temporary plate fixation or others) may now be removed.**



Fig. 30

# Operative technique

## Proximal medial tibia plate

Surgeons may use a medial/ posteromedial surgical approach to the proximal tibia, depending on the fracture pattern. Surgical Exposures in Orthopaedics: The Anatomic Approach, 4th ed., Hoppenfeld et al.

### Patient position

Place the patient in the supine position on a radiolucent table to allow radiographic visualization from mid-thigh to ankle. A small bump under the contralateral hip will exentuate operative leg external rotation, allowing better viewing of the posteromedial proximal tibia (fig. 31). Use a leg elevator to provide leg support to allow fluoroscopy of the tibia in both the AP and lateral views. This will avoid interference from the contralateral leg and having to lift the operative leg for lateral radiographs. A tourniquet on the proximal thigh will help decrease blood loss and allow better visualization of the anatomy. Prep and drape the leg circumferentially extending at least to the mid-thigh to allow proximal extension of the surgical incision if needed.

### Surgical approach

Used for fractures that require fixation of the medial column of the proximal tibia. An incision is made from the medial epicondyle extending distally along the posteromedial border of the tibia. The saphenous vein and nerve lie anterior to the incision and should be identified and protected.

Incise the fascia and identify the pes anserine. The pes anserine can be incised longitudinally or the anterior fibers can be elevated from the tibia and retracted posteriorly. Retract the medial gastrocnemius muscle posteriorly.

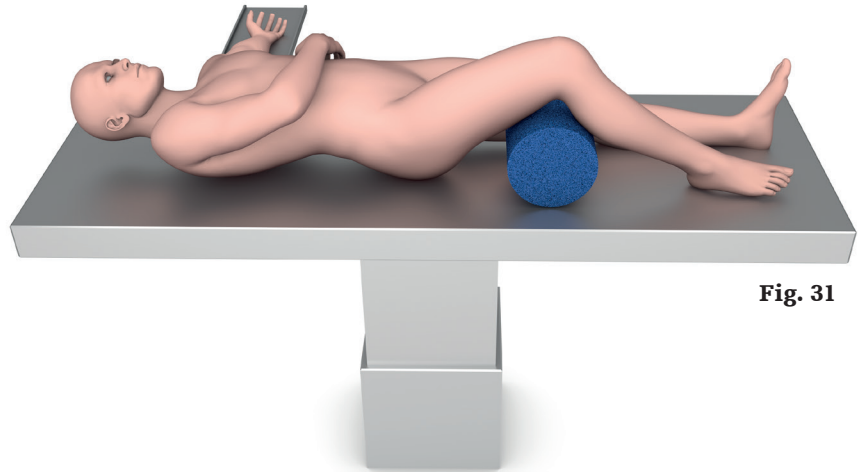

**Fig. 31**

# Operative technique

## Proximal medial tibia plate

### Articular reduction

Anatomical reduction of the fracture should be performed either by direct visualization with the help of percutaneous reduction clamps (fig. 32) (Refer to Stryker reduction instrument system literature number LTRB) and/or K-wires, or alternatively by using a bridging external fixator. Fracture reduction of the articular surface should be confirmed by direct visualization, or fluoroscopy. Use K-wires as necessary to temporarily secure the reduction.

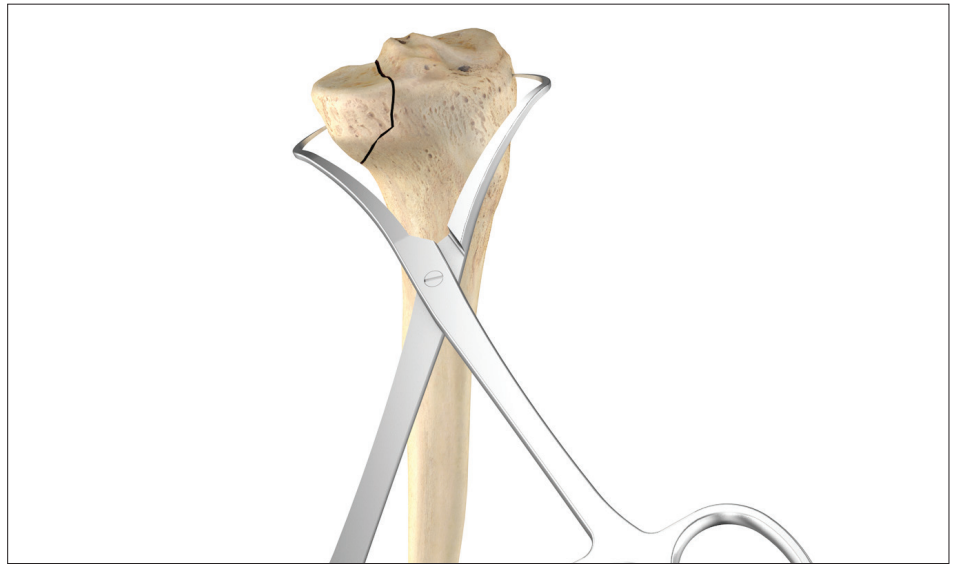

Fig. 32

Typically, K-wires set parallel to the joint axis will not only act to hold and support the reduction, but also help to visualize/identify the joint line. Care must be taken that these do not interfere with the required plate and screw positions. Consideration must also be taken when positioning independent lag screws prior to plate placement to ensure that they do not interfere with the planned plate location or locking screw trajectories. If any large bony defects are present, they should be filled by either bone graft or bone substitute material.

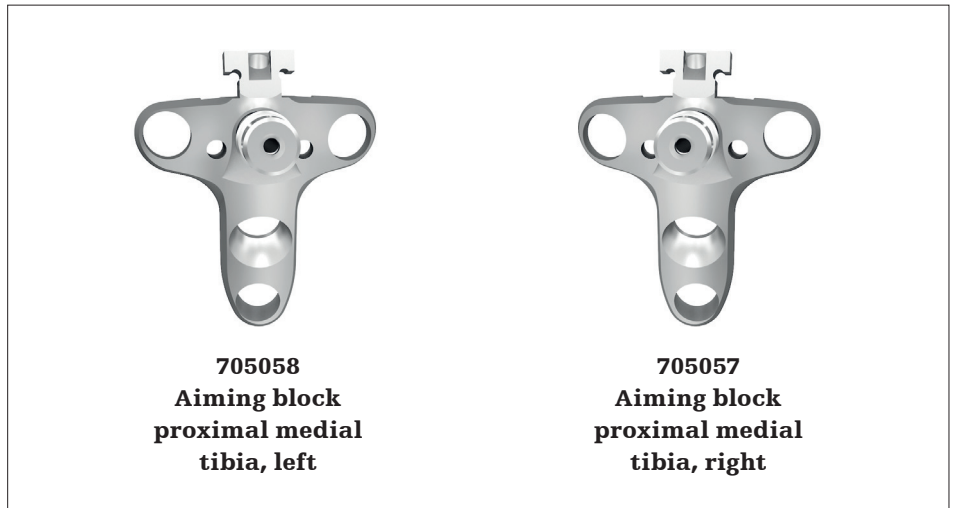

Fig. 33

# Operative technique

## Proximal medial tibia plate

### Plate insertion

In order to help facilitate drill sleeve insertion as well as plate handle attachment to the plate, the aiming block may be used.

Attach the correct aiming block (ref 705057 for left, 705058 for right tibia, fig. 33, 34) to the plate using the attachment screw by hand.

Combined with the attachment screw, the placement of a drill sleeve short (ref 705004) or medium (ref 705075), is recommended to provide additional stability, especially if the plate will be positioned using the handle for plate insertion (ref 702778).

If desired, the handle for plate insertion (ref 702778) can now be attached to the aiming block in order to help facilitate plate positioning and sliding of longer plates sub-muscularly (fig. 35 on the next page). Prior to plate insertion, the soft tissue elevator (ref 702782) can be used to prepare the plate pathway next to the periosteal tissue.

After skin incision and anatomical reduction is achieved, apply and manipulate the plate until optimal position in relation to the joint is achieved.

This helps to ensure that the metaphyseal locking screws are directly supporting the joint surface.

For temporary plate fixation a temporary plate fixator pin (ref 705019) is inserted bicortically through one of the universal holes in the shaft. Follow the instructions for the proximal lateral tibia on page 19 (fig. 27).

The sleeve is then applied over the pin and threaded to push the plate to the bone.

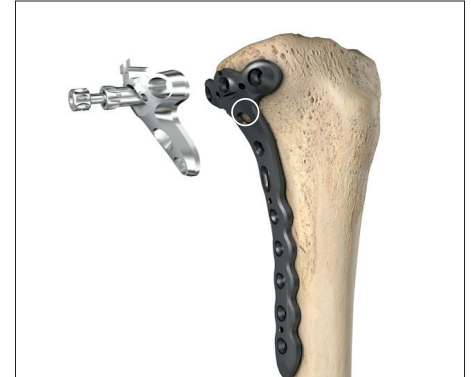

Fig. 34

### NOTICE

**The most proximal shaft hole on the proximal medial tibia plate is non-locking (fig. 34).**

# Operative technique

## Proximal medial tibia plate

### Primary plate fixation

The K-wire holes in the plates allow temporary plate fixation in the metaphysis and the shaft of the plate. Using the K-wire sleeve (ref 705003) in conjunction with the drill sleeve short (ref 705004) or medium (ref 705075), a K-wire (ref 705002) can then be inserted into one of the metaphyseal plate holes (fig. 35, 36).

This step shows the position of the screw in relation to the joint surface and allows for confirmation that the screw will not be intra-articular. Using fluoroscopy, check the position of the K-wire until the optimal position is achieved and the plate is correctly positioned. Correct proximal placement should also be re-confirmed at this point to make sure that the plate shaft is properly aligned over the surface of the tibial shaft. Secure the position by inserting a K-wire. Depending on the fracture pattern, the proximal medial tibia plate can also be positioned postero-medially (fig. 38).

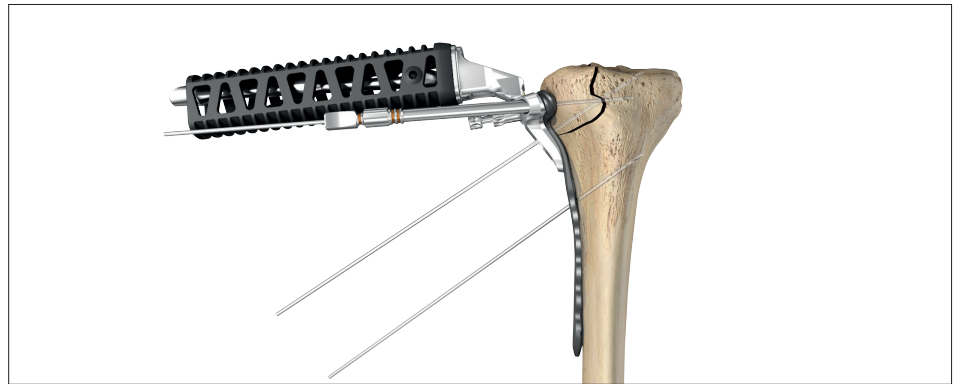

Fig. 35



Fig. 36



Fig. 37



Fig. 38



# Operative technique

## Proximal medial tibia plate

If the distal and axial alignment of the plate cannot be achieved, the K-wires should be removed, the plate readjusted, and the above procedure repeated until both the K-wires and the plate are in the desired position.

Additional K-wires can be inserted to further help secure the plate to the bone and also support depressed areas in the articular surface.

K-wires may be inserted in K-wire holes, the K-wire sleeve attached to the drill sleeve, or through any hole.

Removal may be required as screws are applied to the plate.

### NOTICE

**Do not remove the K-wires, K-wire sleeves and drill sleeves at this point as it will cause a loss of the plate position.**

**Remove the handle for plate insertion (ref 702778) by pushing the metal lever sideways on top of the handle.**

### Plate fixation

For detailed explanation of plate fixation with non-locking or locking screws please refer to the "general guidelines" section. In case non-locking and locking screws are mixed in the same plate it is recommended to seat non-locking screws before the locking screws are inserted following the "lag before lock" principle.

All provisional plate fixation devices (K-wires, temporary plate fixation or others) may now be removed.

## Operative technique

### Distal anterolateral and distal medial tibia plates

Surgeons may use an anterolateral or medial approach to the distal tibia, depending on the fracture pattern. *Surgical Exposures in Orthopaedics: The Anatomic Approach*, 4th ed., Hoppenfeld et al.

#### Patient position

Place the patient in the supine position on a radiolucent table to allow radiographic visualization from knee to ankle (fig. 39). A small bump under the ipsilateral hip will help correct proximal leg external rotation. Use a leg elevator to provide leg support and allow fluoroscopy of the distal tibia in the AP, mortise, and lateral views. This will avoid interference from the contralateral leg and the need to lift the operative leg for lateral radiographs.

A tourniquet on the proximal thigh will help decrease blood loss and allow better visualization of the anatomy. Prepare and drape the leg circumferentially extending at least to the knee to allow proximal extension of the surgical incision if needed.

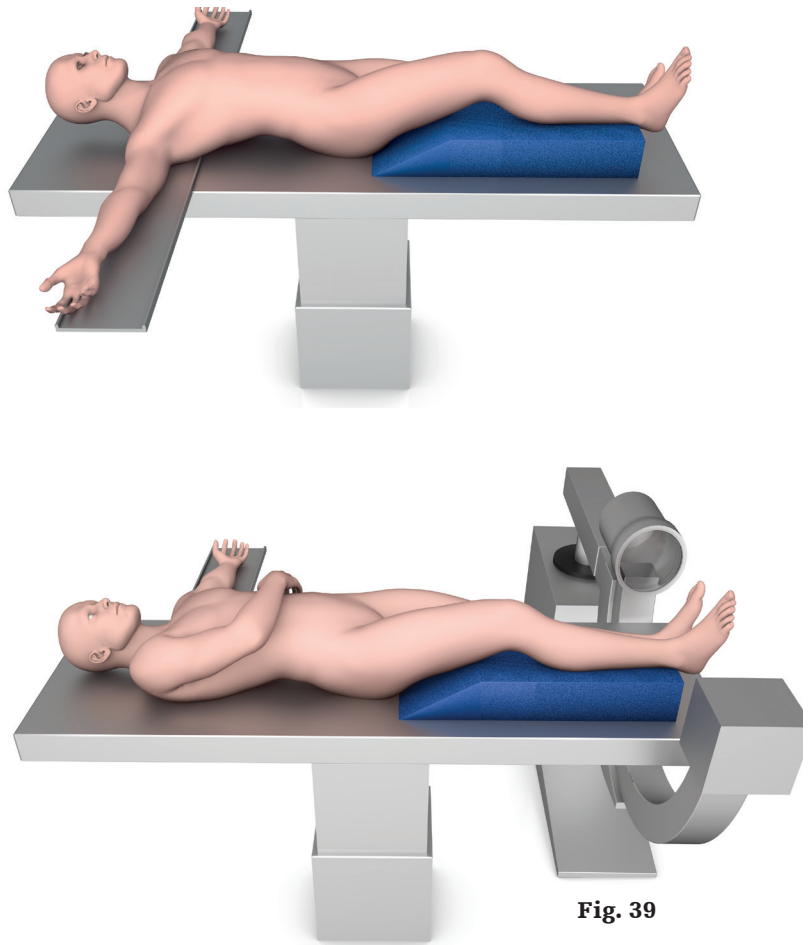

Fig. 39

# Operative technique

## **Distal anterolateral and distal medial tibia plates**

### **Surgical approach distal medial tibia**

Surgical approach is used for OTA a, b and some c fractures. The skin incision starts just distal to the medial malleolus and extends proximally along the medial border of the tibia. Incision position can vary over the anterior or posterior part of the medial malleolus, depending on the fracture pattern.

The saphenous vein is found along the anterior part of the medial malleolus and care should be taken to protect the tibial nerve and posterior tibial artery near the posterior part of the malleolus. Great care should be taken during the closure of this incision to prevent wound dehiscence since plate placement is subcutaneous, as opposed to the sub-muscular placement of the anterolateral distal tibia plate.

### **Surgical approach distal anterolateral tibia**

Surgical approach can be used for OTA a, b, and c fractures. An incision is made approximately 1cm lateral to the tibial apex and extends distally across the ankle toward the fourth metatarsal. The length of the proximal extension of the incision is mandated by the fracture pattern/length. Incise only the skin as branches of the superficial peroneal nerve are subcutaneous. Incise the anterior fascia and extensor retinaculum in line with the skin incision. Mobilize the extensor hallucis longus and extensor digitorum longus tendons, noting that the neurovascular bundle (deep peroneal nerve and dorsalis pedis artery) lies between them. Make an ankle arthrotomy and retract the tendons appropriately for adequate visualization of the distal tibia.

# Operative technique

## Distal tibia plates

### Articular reduction

Anatomical reduction of the fracture should be performed either by direct visualization with the help of percutaneous reduction clamps (refer to Stryker reduction instrument system literature number LTRB) or K-wires or alternatively by using a bridging external fixator.

Fracture reduction of the articular surface should be confirmed by direct visualization, or fluoroscopy. Use K-wires as necessary to temporarily secure the reduction (fig. 40). Typically, K-wires set parallel to the joint axis will not only act to hold and support the reduction, but also help to visualize / identify the joint line. Care must be taken that these do not interfere with the required plate and screw positions. Consideration must also be taken when positioning independent lag screws prior to plate placement to ensure that they do not interfere with the planned plate location or locking screw trajectories.

If any large bony defects are present, they should be filled by either bone graft or bone substitute material.

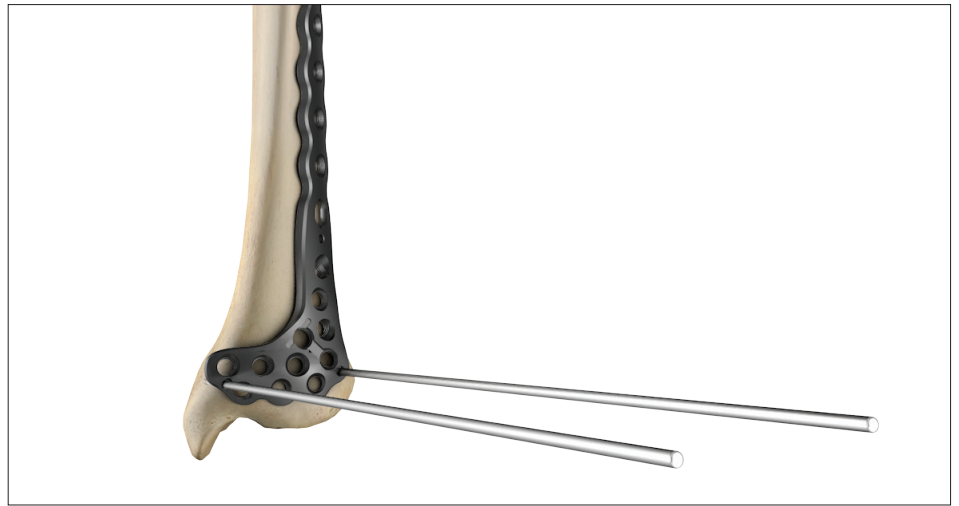

Fig. 40

# Operative technique

## Distal tibia plates

### Plate insertion

In order to help facilitate drill sleeve insertion as well as plate handle attachment to the plate, the aiming block may be used. Attach the correct aiming block (fig. 41–43) to the plate using the attachment screw by hand. Combined to the attachment screw the placement of a drill sleeve short (ref 705004) or medium (ref 705075), is recommended to provide additional stability.

Especially if the plate will be positioned by using the handle for plate insertion (ref 702778).

If desired, the handle for plate insertion (ref 702778) can now be attached to the aiming block in order to help facilitate plate positioning and sliding of longer plates submuscularly or subcutaneously. Prior to plate insertion, the soft tissue elevator (ref 702782) can be used to prepare the plate pathway next to the periosteal tissue (fig. 44).

After skin incision and anatomical reduction is achieved, apply and manipulate the plate until optimal position in relation to the joint is achieved.

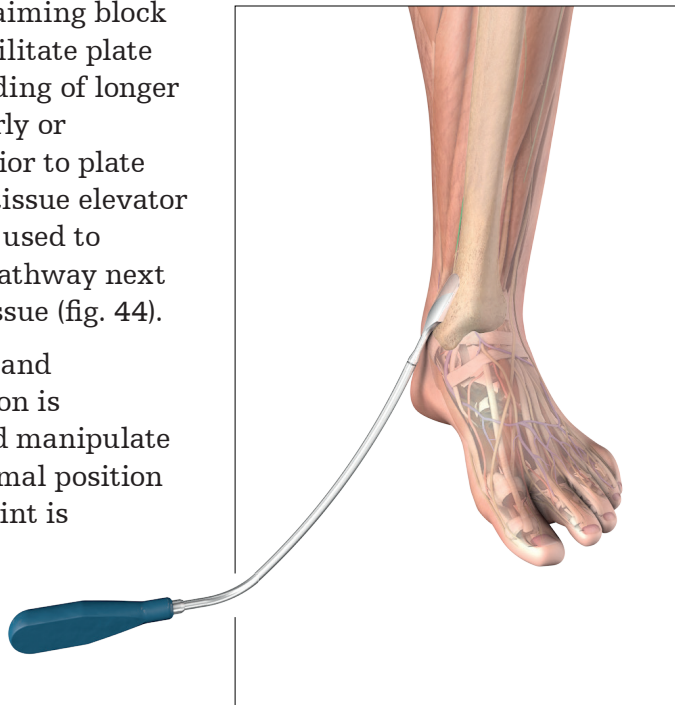

Fig. 44

This helps to ensure that the metaphyseal locking screws are directly supporting the joint surface.

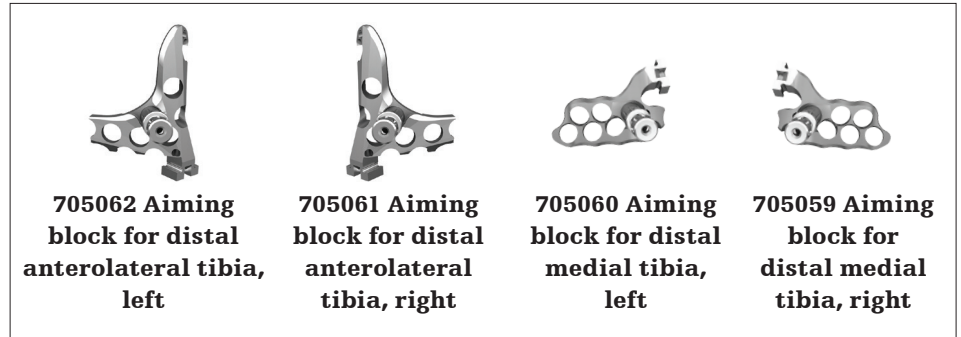

Fig. 41

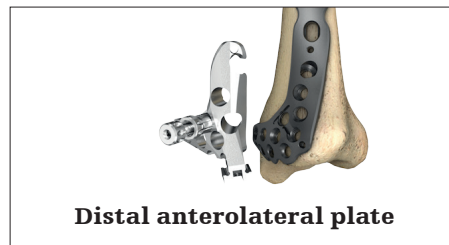

Fig. 42

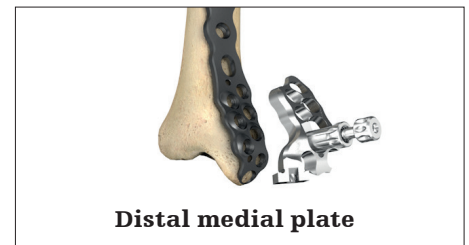

Fig. 43

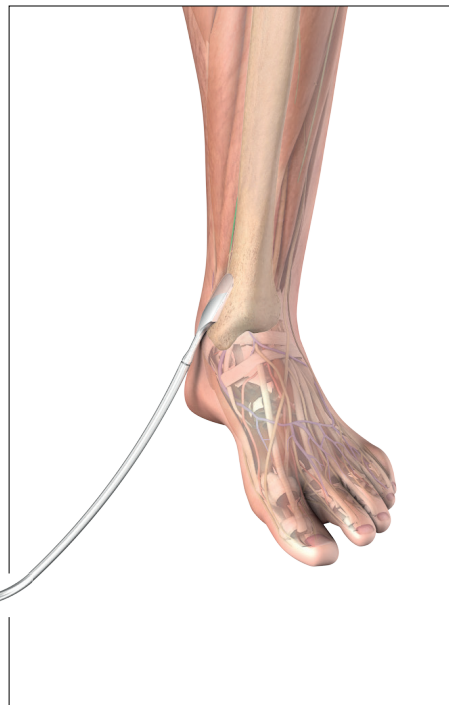

Fig. 44

For temporary plate fixation a temporary plate fixator pin (ref 705019-1) is inserted bi-cortically through one of the shaft holes.



Fig. 45



Fig. 46

The sleeve is then applied over the pin and threaded to push the plate to the bone (fig. 45, 46).

# Operative technique

## Distal tibia plates

### Primary plate fixation

The K-wire holes (marked pink in fig. 47 and 48) in the plates allow temporary plate fixation in the metaphysis and the shaft of the plate. Using the K-wire sleeve (ref 705003) in conjunction with the drill sleeve short (ref 705004) or medium (ref 705075), a K-wire (ref 705002) can then be inserted into one of the universal holes of the metaphyseal area. This step shows the position of the screw in relation to the joint surface and allows for confirmation that the screw will not be intra-articular. Using fluoroscopy, check the position of the K-wire until the optimal position is achieved and the plate is correctly positioned. Correct proximal placement should also be re-confirmed at this point to make sure that the plate shaft is properly aligned over the surface of the tibial shaft (fig. 47, 48).

Secure the position by inserting a K-wire. If the distal and axial alignment of the plate cannot be achieved, the K-wires should be removed, the plate readjusted, and the above procedure repeated until both the K-wires and the plate are in the desired position. Additional K-wires can be inserted to further help secure the plate to the bone and also support depressed areas in the articular surface.

K-wires may be inserted in: K-wire holes (marked pink in fig. 47, 48), the K-wire sleeve attached to drill sleeve, or through any hole. Removal may be required as screws are applied to the plate.

**NOTICE**

**Do not remove the K-wires, K-wire sleeves and drill sleeves at this point as it will cause a loss of the plate position.**

Remove the handle for insertion by pushing the metal lever on top of the handle sideways.

**Notes:**  
**See next page.**

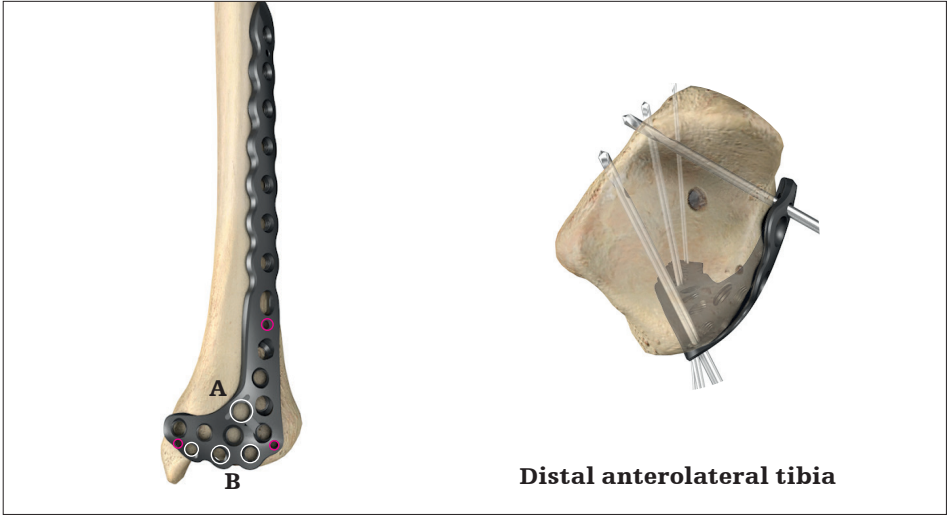

**Fig. 47**

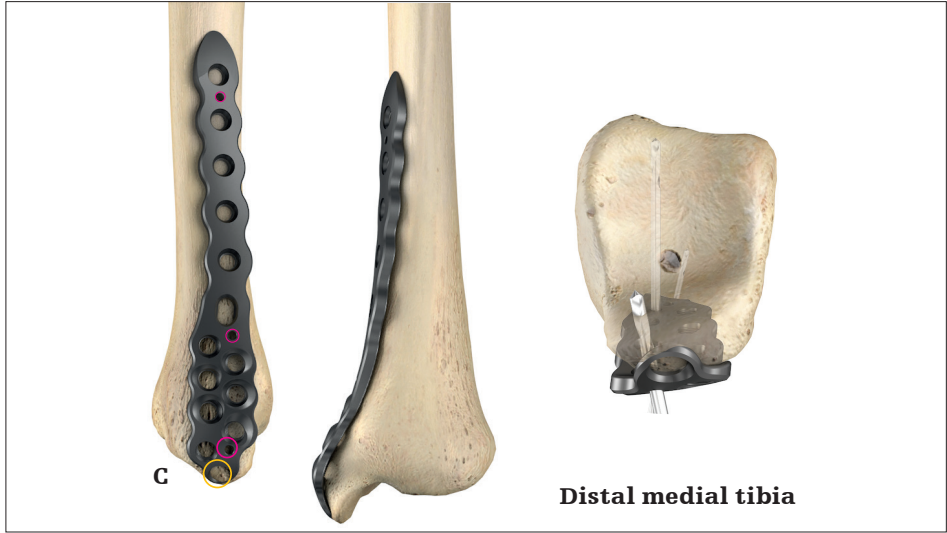

**Fig. 48**

# Operative technique

## Distal tibia plates

### Plate fixation

For a detailed explanation of plate fixation with non-locking or locking screws please refer to the “general guidelines” section. In case non-locking and locking screws are used in the same plate it usually is recommended to seat non-locking screws before the locking screws are inserted -following the "lag before lock" principle. All provisional plate fixation devices (K-wires, temporary plate fixation or others) may now be removed.

#### NOTICE

**The threaded targeter attachment hole in the distal anterolateral tibia plate (A, marked white in fig. 47) does not allow for any bone screw fixation. The most distal holes (B, marked white in fig. 47) can be filled with 3.5mm or 2.7mm non-locking screws only. These holes do not accept any locking screws.**

#### NOTICE

**To place a 2.7mm SPS Titanium Screw, please use the corresponding 2.0mm drill bit (ref 700346), double drill guide (ref 702416) and the 2.5mm hex screwdriver (ref 702485) from the add-on insert.**

#### NOTICE

**The most distal hole in the distal medial tibia plate (c, marked yellow in fig. 48) only accepts 3.5mm cortical or 4.0mm cancellous screws. This hole does not accept any locking screws.**

## Additional tips

### ⚠ CAUTION

**1. Always use the locking drill sleeve when drilling for locking screws.**

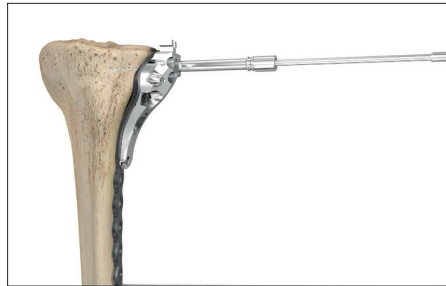

Freehand drilling can lead to a misalignment of the screw and may result in screws cross-threading during final insertion. It is essential to drill the core hole in the correct trajectory to facilitate accurate insertion of the locking screws.

**2. It is best to insert the screw manually** to ensure proper alignment in the core hole which aligns the screw so it locks properly after being fully advanced. It is recommended to start inserting the screw using **“the three finger technique”** on the teardrop handle.

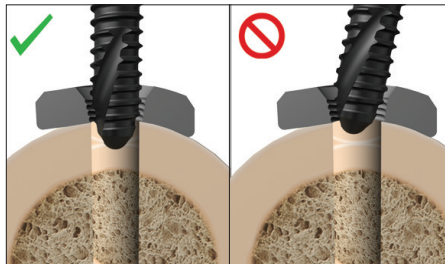

Locking screws should be aligned perpendicularly to the plate / hole. If the locking screw head does not immediately engage the plate thread, reverse the screw and re-insert the screw once it is properly aligned.

### ⚠ CAUTION

**3. Use low speed only and do not apply axial pressure** if power screw insertion is selected. Stop power insertion approximately 1cm before engaging the screw head in the plate.

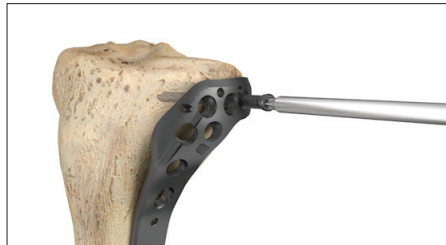

Power can negatively affect final screw insertion, and if used improperly, could damage the screw /plate interface (screw jamming). This can lead to the screw head breaking or being stripped.

**4. It is advisable to tap hard (dense) cortical bone** before inserting a locking screw. Use the 4.0mm locking tap (ref 702772).

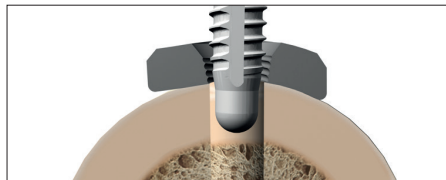

The spherical tip of the tap is designed to precisely align with the instrument in the pre-drilled core hole during thread cutting. This will facilitate subsequent screw placement.

### ⚠ CAUTION

**5. Do not use power for final insertion of locking screws.** It is imperative to engage the screw head into the plate using the torque limiter.

Ensure that the screwdriver tip is fully seated in the screw head, but do not apply axial force during final tightening. If the screw stops short of final position, back up a few turns and advance the screw again (with torque limiter on).

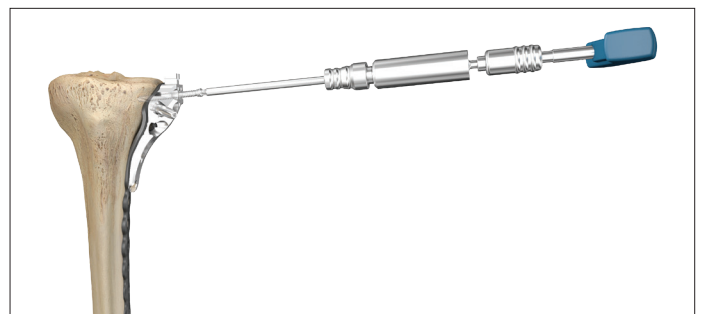



# SPS Titanium – AxSOS 3 Titanium compatibility chart

## Screws

The chart shows the compatibility of SPS Small and Basic Fragment Titanium screws with AxSOS 3 Titanium Plates and vice-versa.

			AxSOS 3 Ti 4.0mm						AxSOS 3 Ti 5.0mm						SPS 3.5mm			SPS 4.5mm			SPS 2.7mm							
			661014/-095	661410/-520	607310/-400	607410/-500	661612/-640	661004	661114/-195	661714/-850	608230/-350	608020/-150	608445/-550	661922/-975	661308/-320	661005	991088S	661002S	603010/-090	604010/-060	604210/-260	601014/-150	602030/-150	602245/-400	602420/-550	605008/-060		
			4.0mm locking Ti screw	3.5mm cortex Ti screw	4.0mm cancellous Ti screw - full thread	4.0mm cancellous Ti screw - partial thread	3.5mm cortex shaft Ti screw	4.0mm blind screw	5.0mm locking screw	4.5mm cortex Ti screw	6.0mm cancellous Ti screw - TL-16	6.0mm cancellous Ti screw - full thread	6.0mm cancellous Ti screw - TL-32	4.5mm cortex shaft Ti screw	5.0mm periprosthetic locking screw	5.0mm blind screw	5.0mm variable angle extension arm*	5.0mm cable plug	SPS 3.5mm Ti cortical screw	SPS 4.0mm Ti cancellous full	SPS 4.0mm Ti cancellous partial	SPS 4.5mm Ti cortical screw	SPS 6.5mm Ti cancellous 16.0mm	SPS 6.5mm Ti cancellous 32.0mm	SPS 6.5mm Ti cancellous full thread	SPS 2.7mm Ti cortical screw		
<b>Plates</b>	<b>AxSOS 3 Ti 4mm</b>	627302/-352	Proximal lateral tibia plate	X	X	X	X	X	X										X	X	X							
		627404/-452	Distal medial tibia plate	X	X	X	X	X	X											X	X	X						
		627454/-500	Distal anterolateral tibia plate	X	X	X	X	X	X											X	X	X						X
		627704/-752	Proximal medial tibia plate	X	X	X	X	X	X											X	X	X						
		627203/-250	Proximal lateral humerus plate	X	X	X	X	X	X											X	X	X						
		627502/-520	4mm compression plate	X	X	X	X	X	X											X	X	X						
		<b>AxSOS 3 Ti 5mm</b>	627604/-650	Distal lateral femur plate							X	X	X	X	X	X	X	X					X					
	627532/-552		5mm compression plate narrow								X	X	X	X	X	X	X	X					X					
	627566/-582		5mm compression plate broad								X	X	X	X	X	X	X	X					X					
		<b>SPS Small Fragment</b>	621423/-436	T-plate		X	X	X	X											X	X	X						
	621463/-468		Oblique T-plate		X	X	X	X												X	X	X						
	621443/-450		Cloverleaf plate		X	X	X	X												X	X	X						
	621122/-134		One third tubular plate		X	X	X	X												X	X	X						
		<b>SPS Basic Fragment</b>	620413/-413	T-plate																			X	X	X	X		
	620454/-458		T-buttress plate																				X	X	X	X		
	620704/-706		L-buttress plate, left																				X	X	X	X		
	620754/-758		L-buttress plate, right																				X	X	X	X		

\* This product is not CE marked in accordance with applicable EU regulations and directives. Stryker is not marketing or distributing this product in the EU. Any reference to this product is for presentation purposes only.

# Notes

# Notes

This document is intended solely for the use of healthcare professionals. A surgeon must always rely on his or her own professional clinical judgment when deciding whether to use a particular product when treating a particular patient. Stryker does not dispense medical advice and recommends that surgeons be trained in the use of any particular product before using it in surgery.

The information presented is intended to demonstrate a Stryker product. A surgeon must always refer to the package insert, product label and/or instructions for use, including the instructions for cleaning and sterilization (if applicable), before using any Stryker product. Products may not be available in all markets because product availability is subject to the regulatory and/or medical practices in individual markets. Please contact your Stryker representative if you have questions about the availability of Stryker products in your area.

Stryker Corporation or its affiliates own, use, or have applied for the following trademarks or service marks: AxSOS, AxSOS 3, Stryker. All other trademarks are trademarks of their respective owners or holders.

If not indicated specifically in this operative technique the products listed above are CE marked.

Content ID: AxSOS-ST-48 Rev 5, 10-2019

Copyright © 2019 Stryker



CE 0123

**Manufacturer:**

Stryker GmbH  
Bohnackerweg 1  
2545 Selzach  
Switzerland  
[stryker.com](http://stryker.com)